

Annual Report
of the
Cochuah Regional Archaeological Survey's
2010 Field Season

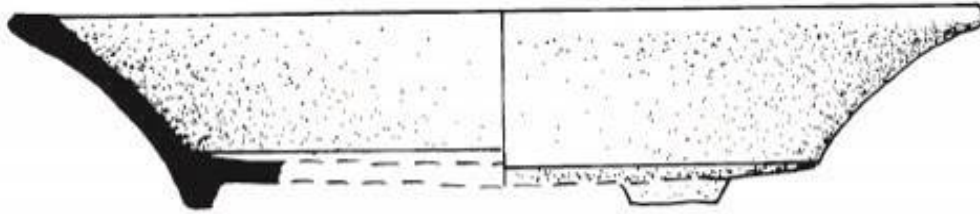

edited by Justine M. Shaw, Alberto G. Flores Colin, and Dave Johnstone

with contributions by Alejandra Badillo Sanchez, Vania Carrillo Bosch, Bryce Davenport, Alberto G. Flores Colin, Luis Fernando Hernández Lara, Jorge Huerta Pablo Rodriguez, Thania Ibarra Estefania Narvaez, Dave Johnstone, Johan Normark, Justine M. Shaw and Tatiana Young

Translated by Alberto G. Flores Colin

Cover illustration by Dave Johnstone

Table of Contents

Acknowledgments v

List of Tables and Figures xv

Part 1: Introduction to the 2010 CRAS Field Season

Chapter 1: Foci of the 2010 CRAS Field Season..... 1

Chapter 2: CRAS Research Methods..... 6

Part 2: The *Ejido* of Saban

Chapter 3: The Site of Abuelos 8

Chapter 4: The Site of Chumpich..... 10

Chapter 5: One Space, Two Places: The Maya and the Military: A Constructed Landscape in the Northwest Region of Yo’okop 13

Chapter 6: Gruta de Alux, Operations 1 and 2 46

Chapter 7: The Site of El Palomar 52

Chapter 8: The Site of Pancho Villa 54

Chapter 9: Sak Chikin and Chuunkatzin 56

Chapter 10: Sahcabchen, Operations 1, 2 and 3..... 59

Chapter 11: The Site of San Isidro, Saban 65

Chapter 12: The Site of La Trinchera 67

Chapter 13: The Site of Venadito 69

Chapter 14: The Site of Yaxche 1 71

Part 3: The *Ejido* of Sacalaca

Chapter 15: The Site of Ixbaquil	73
Chapter 16: Parcela Escolar, Operations 2 and 3	78
Chapter 17: The Site of Ramonal Oriente, Sacalaca	87
Chapter 18: The Site of Rancho San Diego	90
Chapter 19: The Site of Rancho San Isidro	94
Chapter 20: The Site of Rancho San Juan	97
Chapter 21: The Site of Rancho Santa Elena	101
Chapter 22: The Site of Santa Cruz	104
Chapter 23: The Site of Xbalcheil	106
Chapter 24: The Site of Xtojil	108
Chapter 25: The Site of Yo'dzonot, Sacalaca	113

Part 4: The *Ejido* of San Felipe

Chapter 26: Hopemul, Operation 1	121
Chapter 27: Ramonal Quemado, Operation 1	124
Chapter 28: Ramonal Quemado, Operation 2	130
Chapter 29: Ramonal Quemado, Operation 3	134
Chapter 30: Ramonal Quemado, Operation 4	138
Chapter 31: Ramonal Quemado, Operation 5	142
Chapter 32: San Felipe, Operation 2	146
Chapter 33: San Felipe, Operation 3	149
Chapter 34: San Felipe, Operations 4 and 5	154
Chapter 35: San Lorenzo, Operation 1	163

Chapter 36: San Lorenzo, Operation 2	168
Chapter 37: San Lorenzo, Operation 3	173
Chapter 38: San Lorenzo, Operation 4	177
Chapter 39: San Lorenzo, Operation 5	181
Chapter 40: Sisal, Operation 2	184
Chapter 41: Sisal, Operation 3	188
Chapter 42: Sisal, Operation 4	197
Chapter 43: Sisal, Operation 5	199
Chapter 44: Sisal, Operation 6	203
Chapter 45: Sisal, Operation 7	207

Part 5: Summary and Analysis

Chapter 46: Under the Foliage of Oblivion: Peripheries and New Sites in the <i>Ejidos</i> of Sacalaca and Saban	214
Chapter 47: Documentation of Water Wells in the Coahuah Region	231
Chapter 48: Ceramic Summary of the 2010 Field Season of the Coahuah Regional Archaeological Survey	258
Chapter 49: Conclusions	342
References Cited	346

NOTE: Copies of this report, as well as previous reports of the CRAS Project and Yo'okop Project are available on our website:

<http://online.redwoods.cc.ca.us/yookop/>

This website also contains photographs and updates not included in this report from this season and previous seasons.

Acknowledgments

The 2010 field season was funded by the Selz Foundation with additional support being provided by the Swedish International Development Cooperation Agency (SIDA) and the Swedish Research Council (VR). The 2008 field season was funded by the Selz Foundation and the Antiqua Foundation. The 2003, 2004, and 2005 CRAS field seasons were funded by the Antiqua Foundation, as was our 2002 season at Yo'okop. Additional support for Johan Normark's participation during the 2005 field season was provided by Stiftelsen Lars Hiertas minne. The 2001 Yo'okop season was made possible by a grant from the Selz Foundation. We very much appreciate the support and encouragement that Bernard Selz has continued to provide to us through the years. The 2000 season was funded by the H. John Heinz III Fund of the Heinz Family Foundation (reference number H1305) and the Foundation for the Advancement of Mesoamerican Studies Inc. (FAMSI project number 99016). Johan Normark has received financial support for the fieldwork from Den Adlerbertska forskningsstiftelsen. These agencies have allowed Johan to do research before and after the fieldwork: Stiftelsen Fru Mary von Sydows, född Wijk, donationsfond, Helge Ax:son Johnsons stiftelse, Gunvor och Josef Anérs stiftelse, Stiftelsen Wilhelm och Martina Lundgrens vetenskapsfond, and Birgit och Gad Rausings stiftelse för humanistisk forskning. Adam Kaeding received funding from the Boston University Graduate Research Abroad Fellowship. Without all of these funds, our research in this region would not have been possible.

We also would like to thank our colleagues from the United States, Canada, Sweden, and Mexico, including INAH-QR and INAH-Nacional, for helping us with our sixth season of research. Adriana Velazquez Morlet, director of INAH-Quintana Roo, has been incredibly helpful in helping us to continue our research in the Coahuah region. Also, our Project ethnographers Sandra Bever and Veronica Miranda provided us with advice on matters related to the modern Maya and continue to assist as a liaison between the Project and government officials.

Additionally, the members of Project would like to thank our family and friends, who have been incredibly patient and supportive.

Finally, and most importantly, we would like to thank the people of Huay Max, Ichmul, Sacalaca, Saban, San Felipe, Tabasco, and Xquerol who have graciously allowed us to live and work in their *ejidos* during our summers. In addition to the crew members we were able to hire (following pages), we received countless archaeological (and survival) tips and assistance from individuals throughout the *ejidos*.

Saban *Ejido* Field Crew

Group 1

Alejandro Kauil Chan
Mariano Caamal Poot
Eujenio Tuyub May
Felipa Canul Mex
Florentino Poot Kauil
Tomas Poot Poot
Alfredo Tuyub Moo
Emilio Tulub Canul
Marcelino Chimal Hau
Alvaro Cham Pech
Martina Dzib Tuz
Celiano Moo Ceh

Group 2

Marcelino Poot Poot
Carmen Kan Cahum
Santos Juan Tuz Arjona
Angel Moo Uc
Jose Angel Pat Tun
Nemecio Tuz Ake
Antonia Mukul
Saturnino Chuc Ku
Cornelio Poot Poot
Severiano Mahay Chuc
Daniel Tuz Ake
Daniel Castillo Cocom

Group 3

Anastacio Canul Lopez
Martiano Moo Uch
Bonifacio Moo Balam
Maxima Cab Chuc
Eusebio Uc Moo
Matilde Chan Caamal
Nicolas Tun Itza
Cayetano Chan Caamal
Onesimo Tun Cahum
Fortunato Chan Pat
Nestor Balam Chi
Alfonso May Tuyub
Wiliam Chan Poot
Alejandro Chan Tuz
Jose Alfredo Chan
Iturcalano Chan Kauil
Victor Chan Pat
Juan Chan Tuz

Group 4

Claudio Chan Moo
Juan Angel Tum Huicab
Serapio Moo Noh
Carlos Chan Nahuat
Bonifacio Kauil Chi
Armando Pool Oxté
Maximino Ake Mahay
Antonio Moo Arjona
Fernando Poot Chan
Modesto Chan Moo
Jaime Valentin Estrada Blanco
Eulogia Chimal Tuz

Sacalaca *Ejido* Field Crew

Group 1

Bonifacio Alvarez Chay
Maximiliano Alvarez Chay
Francisco Un Caamal
Alejandro Alvarez Canul
Gregorio Canul Alvarez
Jose Amancleto Un Noh
Arcenio Caamal Pech
Arcenio Ake Chan
Roberto Pech Mahay
Demetrio Cocom Mahay
Silvestre Cahum Mahay
Severo Wicab Canul

Group 2

Primitivo Noh Uc
Anastacio Un Noh
Valerio Noh Mahay
Raul Noh Uc
Bartomome Canul Alvarez
Feliciano Caamal Pech
Benjamin Chi Dzib
Beato Cocom Mahay
Fernando Canul Cocom
Victor Mahay Caamal
Buenaventura Can Cab
Felipe Un Coyoc

Group 3

Migueas Chi Dzib
Modesto Chi Dzib
Anastacio Cahun Mahay
Eluterio Noh Juchim
Geronimo Un Pech
Eustaquio Noh Un
Jonas Mahay Noh
Rogelio Chi Caamal
Julian Cahum Poot
Baleviano Hernandez Poot
Miguel Noh Cahum
Rafael Cahum Cohuo

Group 4

Geremias Alvarez Canul
Gaspar Chi Cohuo
Federico Noh Uc
Casiano Chi Cohuo
Macedonio Caamal Cahum
Monger Cahum Moo
Federico Cahum Poot
Hipolito Un Noh
Pascual Chi Caamal
Modesto Un Noh
Buenaventura Un Dzib
Bonifacio Can Cab

Group 5

Enrique Dzib Canche
Silvino Un Caamal
Nabor Un Noh
Alejandro Cahum Mahay
Fausto Pech Cohuo
Florencio Un Noh
Noe Cohuo Noh
Natalio Noh Pech
Wilfrido Canul Alvarez
Serapio Poot Mahay
Bernabe Caamal Poot
Rafael Noh Un

Group 6

Marcario Dzul Un
Nicanor Poot Cohuo
Bernabe Mahay Kauil
Armando Noh Chi
Jesus Manuel Un Hoil
Francisco Noh Uc
Artemio Ake Poot
Isabel Chi Un
Julian Canul Mex
Onorio Cahuich Chuc
Vicente Noh Pech
Fausto Noh Dzul
Eluterio Chi Dzib
Margarito Chan Poot
Alberto Noh Chi

Group 7

Isidro Chi Cohuo
Jose Isabel Chi Un
Marino Canul Alvarez
Julian Chi Cohuo
Braulio Un Pech
Jose Nestor Muños
Sebastian Can Cab
Justo Cahum Moo
Victor Mahay Caamal
Isidro Chan Poot
Martin Mahay Cahum
Juan Bautista Dzib Pat
Julian Un Noh
Zoila Castillo Navarete
Juvencio Nuñes Castillo
Marco Chi Dzib

Group 8

Marcario Dzul Un
Nicanor Poot Cohuo
Bernabe Mahay Kauil
Armando Noh Chi
Jesus Manuel Uh Hoil
Francisco Noh Uc
Artemio Ake Poot
Isabel Chi Un
Julian Canul Mex
Onorio Cahuich Chuc
Vicente Noh Pech
Fausto Noh Dzul
Eluterio Chi Dzib
Margarito Chan Poot
Alberto Noh Chi

Group 9

Juan de la Cruz Mahay
Benustiano Mahay Chi
Transito Pech Cohuo
Rubéncio Cahum Moo
Severiano Hernandez Mahay
Pablo Noh Noh
Victoria Cahum Mahay
Valerio Noh Mahay
Cesario Pech Cahum
Agustin Noh Mahay
Aurelio Un Alvarez
Jorge Luis Alvarez
Silvestre Cocom Dzib
Francisco Cocom Mahay
Macario Un Dzib
Wilfrido Canul Alvarez

Group 10

Savina Cahuich Chuc
Manuel Jesus Noh Poot
Gonzalo Cahum Dzib
Elmer Cocom Dzib
Nicolas Cahum Cohuo
Victor Chan Cano
Isabel Chi Un
German Canul Alvarez
Migueas Chi Dzib
Eliseo Noh Uc
Jesus Cahum Mahay
Crisanto Canul Hernandez
Rafael Noh Uh
Basilio Pech Cahum
Jose de Jesus Noh Un
Pedro Celestino Cahuich Chuc

Group 11

Josue Natanael Cohuo Mahay
Edilberto Alvarez Mex
Gustavo Caamal Pech
Renato Poot Cohuo
Fulgencio Poot Mahay
Enrique Un Un
Francisco Ake Chan
Francisco Uh Noh
Juan Damaso Uh Hoil
Juan de la Cruz Ake Chan
Humberto Noh Mahay
Valentino Cocom Poot
Juan de Mata Cahum Moo
Roberto Uh Ake
Filemon Cahum Cocom
Ramon Moo Noh

Group 12

Jose Isabel Cohuo
Jaime Cahum Cocom
Andres Cahum Dzib
Gonsalo Un Noh
Eulogio Briceno Castillo
Francisco Pech Uc
Carlos Ake Alvarez
Angel Un Un
Beato Cocom Mahay
Angel Ake Pech
Modesto Dzul Un
Martin Cahum Mahay
Enrique Cahum Cohuo
Antonio Cahum Mahay
Isidro Noh Uc
Fernando Cocom Poot

Group 13

Aurelio Cahum Poot
Jose Atalo Cocom Mahay
Adolfo Cahum Poot
Ebolio Cahum Mahay
Gervacio Pech Mahay
Tranquilino Dzul Noh
Jonas Mahay Noh
Bonifacio Tamay Alvarez
Casiano Chi Cohuo
Gaspar Chi Cohuo
Francisco Ake Chan
Francisco Un Noh
Jeronimo Un Pech
Gilberto Hernandez Ake
Roberto Cahum Moo

Group 14

Andres Noh Ucan
Iriberto Un Noh
Ilario Can Cab
Nicolas Noh Cahum
Julian Un Noh
Susano Noh Ake
Isabel Chan Be
Cesar Gabriel Caamal Pech
Gonzalo Un Noh
Miguel Angel Noh Cahum
Alejandro Reaños Dias
Rafael Cahum Cohuo
Jose Santos Un Noh
Francisco Javier Can Cab
Modesto Chi Dzib
Buenaventura Cahuich Chuc

Group 15

Luis Miguel Mahay Noh
Gervacio Cocom Mukul
Primitivo Noh Uc
Hipolito Cahum Moo
Saturnino Cahum Moo
Anastacio Cahum Mahay
Gregorio Canul Alvarez
Adolfo Chi Un
Mouge Cahum Moo
Francisco Cocom Mahay
Sebastian Can Cab
Jose Isabel Chi Un
Ebolio Cahum Mahay
Elmer Cocom Dzib
Maximiliano Noh Chi
Armando Noh Chi

Group 16

Buenaventura Cauich Chuc
Francisco Noh Mahay
Wilbert Eugenio Alvarez
Victor Mahay Caamal
Saturino Alvarez Canul
Cesario Pech Cahum
Rafael Uh Noh
Carlos Noh Un
Francisco Javier Can Can
Candelario Dzul Kituc
Victor Chan Cano
Roberto Pech Mahay
Julian Cahum Poot
Fredy Uh Noh
Serapio Poot Mahay
Alejandro Cahum Mahay

Group 17

Juan de la Cruz Ake Chan
Francisco Noh Uc
Cesar Gabriel Caamal Pech
Jose Atalo Cocom Mahay

Group 18

Eduardo Alvarez Canul
Federico Cahum Poot
Lazaro Noh Pech
Demetrio Cocom Mahay

Group 19

Alejandro Uh Un
Leopoldo Chi Cohuo
Bonifacio Chi Dzul
Manuel Noh Batun

Group 20

Francisco Noh Mahay
Migueas Chi Cohuo
Hipolito Un Noh
Arcenio Ake Chan

Group 21

Susano Chi Cohuo
Marcelo Cahum Mahay
Candido Un Noh
Geraldo Chi Tun
Maximiliano Alvarez Chay
Paulino Pech Moo

Group 22

Macario Dzul Un
Rafael Noh Un
Faustino Ake Cituk

San Felipe *Ejido* Field Crew,

Group 1

Gabriel A Poot
Sebastian Yam
Raul Borges Poot
Carlos A Borges Yam
Jacob Alamilla

Group 2

Rafael Borges Yam
Rubén Borges Itza
Gabriel Chan Balam
Rodolfo Itza Borges
Pastor Ake

Group 3

Gualberto Borges Poot
Fernando Itza Borges
Primitivo Alamilla
Macario Tut Poot
Carlos Tut Yam
Jose Itza Chi
Juan Tut Yam
Jorge Vicente Borges

Group 4

Miguel Borges
Guadalupe Itza Borges
Gaspar Pool Yam
Eulogio Itza Poot
Cesar Poot Alamilla
Anastasio Yam Yam
Francisco Yam Yam
Paulino Yam Chan

Group 5

Higinio Poot Camal
Isauro Yam Chan
Teodoro Yam Pech
Pedro Yam Nolasco
Felipe Ake
Nicolas Ake Chan
Esteban Ake Chan

Victor Villanueva PootGroup 6

Jaime Ek Caamal
Armando Poot
Saul Poot Colli
Mauro Ortiz
Bernardino Yam Colli
Javier Ake Uc
Gualberto Borges

Group 7

Francisco Villanueva
Jaime Ek Caamal
Eulogio Itza Poot
Pedro Poot Poot
Hidinio Poot
Sebastin Yam
Macario Tut Poot
Carlos Tut Yam
Juan Tut Yam

Group 8

Ismael May Rosel
Francisco Villanueva Peaza
Victor Villanueva
Paulino Yam Chan
Bernardino Yam
Rafael Borges Yam
Carlos Tut Yam
Baltasar Tut Yam
Luis Felipe Itza
Eulogio Itza Poot
Saul Poot Colli
Pastor Ake

Group 9

Virgilia Pech Chi
Jose Itza Chi
Teodoro Yam Pech
Jacob Alamilla Coyi
Sebastian Yam
Carlos Borges Yam
Nicolas Ake Chan
Guadalupe Itza Borges
Javier Ake Uc
Estepan Ake
Felipe Ake Uc
Pedro Nolesco Yam

Group 10

Gabriel Poot Aban
Pedro Nolasco Yam
Raul Borges Poot
Luis Borges Itza
Fernando Borges Poot
Rubén Borges Itza
Anastacio Yam Yam
Jeremías Alamilla Colli
Jose Nicolas May Rosel
Baltasar Tut Yam
Luis Felipe Pech
Rodolfo Itza

Group 11

Fernando Borges
Rodolfo Yam Colli
Jorge Borges Itza
Luis Borges Itza
Francisco Yam
Carlos Tut Yam
Jaime Ek Caamal
Gabriel Poot Ahah
Juan Tut Yam
Victor Villanueva
Francisco Villanueva
Sebastian Yam
Jeremías Alamilla

Group 12

Nicolas May Nal
Rubén Borges Itza
Anastasio Yam Yam
Fernando Borges Poot
Luis Borges Itza
Rodolfo Yam Colli
Juan Tut Yam
Jacobo Alamilla
Carlos Tut Yam
Armando Poot
Fernando Itza Borges
Miguel Borges Yam
Pastor Ake
Macario Tut Poot

Group 13

Isauro Yam Chan
Nicolas May Naal
Victor Villanueva
Francisco Villanueva
Anastacio Yam
Sebastian Yam
Jeremías Alamilla
Baltasar Tut
Macario Tut
Carlos Tut Yam
Adolfo Yam Colli
Cesar Poot
Javier Ake
Juan Tut Yam

Group 14
Jose Itza
Paulino Yam Chan
Gaspar Pool Yam
Isauro Yam
Francisco Yam Yam
Nicolas May Naal
Esteban Ake
Saul Poot
Felipe Ake
Jeremías Alamilla
Anastasio Yam
Victor Villanueva
Juan Tut
Rubén Borges

Sacalaca Ejido Laboratory Crew

Group 1

Maria Isabel Can Can
Wilma Can Can
Maria Rebeca Can Barnet
Rosa Isela Un Noh
Antonia Dzul Cituc
Dalia Gomes Mahay
Laura Cahum Cohuo
Eunice Mahay Cobo
Gloria Rosalia Noh Un

Group 2

Maria Nelsy Noh Hu
Gabriela Cituc Mahay
Carolina Cahuich Mahay
Aurelia Can Cocom
Luz Aurora Chi Cituc
Elena Mahay Dzib
Ofelia Un Poot

Group 3

Maria Emilia Cahum Mahay
Obdulia Un Caamal
Antonia May Cahum
Maria Melisa Dzul Mahay
Maria de la Luz Cahuich
Idelfonsa Un Noh
Bernadina Un Caamal

Group 4

Maria Clarisa Caamal Cahum
Maria Emilia Cahum Poot
Ofelia Un Poot
Melisa Dzul Mahay

Group 5

Blanca Aurora Mahay Noh
Maria Melisa Dzul Mahay
Ana Beatriz Cahum Alvarez
Maria de los Angeles Chi Caamal
Carmy Aduia Cahum Cohuo
Graciela Canul Cante
Carolina de Rocio Cahuich Mahay

Group 6

Sara Yesica Noh Poot
Gabriela del Rocio Chi Chan
Ana Patricia Un Hoil
Ana Lizandra Cahum Poot
Ana Gabriela Cituc Mahay
Maria Gilda Pech Un
Limna Atalia Gomez Mahay
Maria Melisa Dzul Mahay

Group 7

Rosa Adriana Pech Un
Feliciano Tamay Alvarez
Maria Laura Chan Un
Gloria Imelda Mahay Noh
Ana Rosalia Cocom Poot
Maricela Chi Cocom
Maria Guadalupe Noh Un
Imelda Beatriz Noh Hu

Group 8

Erika Maricruz Ake Munoz
Maria Basilia Cocom Ake
Francisca Hernandez Noh
Hermenegilda Ake Un
Zelda Lucely Cocom Ake
Maria Reyna Ake Alvarez
Leydi del Socorro Chan Be
Mayra Mahay

Group 9

Deysi Esmerelda Un Mahay
Lorenza Beatrice Cahum Mahay
Gloria Isabel Noh Un
Maria Ines Cocom Poot
Dominga de Glory Mahay Coho
Mayra de Jesus Cahuich Alvarez
Sandra Cahuich Mahay
Florecina Pech Uc

List of Tables and Figures

Figure 1) Location of the CRAS Study Area.....	2
Figure 2) Sites within the CRAS Study Area.....	3
Figure 3) The Site of Abuelos.....	9
Figure 4) The Site of Chumpich.....	11
Figure 5) Satellite image of Yo'okop.....	15
Figure 6) Okop, Fort No. 7.....	18
Figure 7) Fort of Yo'okop, Bastion 7 and 8.....	19
Figure 8) Sketch Map of the Operation Lines of General Bravo's Forces in Yucatan.....	21
Figure 9) Sketch Map of Yucatan, ca. 1901.....	24
Figure 10) Fort of Yo'okop, Vestiges of Fronted Wall of the NE Bastion.....	28
Figure 11) Fort of Yo'okop, Well and Foss.....	28
Figure 12) Topographic Map of Fort of Yo'okop.....	29
Figure 13) Stone Alignment with Bottles, within Western Redoubt.....	31
Figure 14) Rear Access to the Fort.....	31
Figure 15) Collapse of a Battlement Located into the North Area of the Foss.....	32
Figure 16) Stone pavement North of the Well, Fort of Yo'okop.....	32
Figure 17) Rooms with Semi-circular Structures (ovens), South of the Fort of Yo'okop.....	33
Figure 18) Gunpowder Arsenal or Storage of War Implements.....	33
Figure 19) North-South Stone Alignment, Near the Oven Area, South of the Fort.....	35
Figure 20) SE Bastion, Seen from North to South.....	36
Figure 21) Western and Eastern Features that Link the SE Bastion with the NW Bastion.....	36
Figure 22) Topographic map of Fortín of Yo'oko.....	37
Figure 23) Difference in the Ground Level between the SE Bastion and Western Side of the Fortalice of Yo'okop.....	39
Figure 24) Prehispanic Wall, Located below the SE Bastion of the Fortalice of Yo'okop.....	39
Figure 25) Puuc-style Architectural Feature.....	41
Figure 26) Cut Stones Located South of the Fort of Yo'okop.....	41
Figure 27) Gruta de Alux, Excavation Locations.....	47
Figure 28a) Gruta de Alux, Operation 1, East and South Profiles.....	48
Figure 28b) Gruta de Alux, Operation 1, East and South Profiles.....	49
Figure 29) The Site of El Palomar.....	53
Figure 30) The Site of Pancho Villa.....	55
Figure 31) The Site of Sak Chikin.....	57
Figure 32) The Site of Chuunkatzin.....	58
Figure 33) Sahcabchen, Operation 1, South and West Profiles.....	60
Figure 34) Sahcabchen, Operation 2, West and North Profiles.....	62
Figure 35) Sahcabchen, Operation 3, South and East Profiles.....	64
Figure 36) The Site of San Isidro, Saban.....	66
Figure 37) The Site of La Trinchera.....	68
Figure 38) The Site of Venadito.....	70

Figure 39) The Site of Yaxche 1	72
Figure 40) The Site of Ixbaquil	74
Figure 41) East View of the First Stairway	75
Figure 42) South Façade of Structure N1E2-1	77
Figure 43) Location of Operations 2 and 3 at Parcela Escolar	79
Figure 44) Parcela Escolar, Operation 2, North Profile	82
Figure 45) Parcela Escolar, Operation 2, West Profile	82
Figure 46) Parcela Escolar, Operation 3, North Profile	84
Figure 47) Parcela Escolar, Operation 3, West Profile	84
Figure 48) Two Platforms South of Structure N10W1-1, Parcela Escolar	86
Figure 49) The Northeast Portion of the Site of Ramonal Oriente, Sacalaca	88
Figure 50) The Southwest Portion of the Site Ramonal Oriente, Sacalaca	89
Figure 51) The Site of Rancho San Diego, Sacalaca	91
Figure 52) Water Trough at Rancho San Diego	92
Figure 53) Postclassic Shrine at Rancho San Diego	92
Figure 54) The Site of Rancho San Isidro	95
Figure 55) Detail of Colonial Wall, Viewed from the Well	96
Figure 56) The Site of Rancho San Juan	98
Figure 57) Cut Stones on the Northeast Side of Structure S1E1-1	99
Figure 58) Top of the Structure S1E1-1	99
Figure 59) The Site of Rancho Santa Elena	102
Figure 60) The Site of Santa Cruz, Sacalaca	105
Figure 61) The Site of Xbalcheil	107
Figure 62) The Site of Xtojil	109
Figure 63) Stairway of Structure N1W1-3 at Xtojil	111
Figure 64) <i>Pila</i> Near the Entrance of Aktun (cave) Xtojil	112
Figure 65) Yo'dzonot Well Area	114
Figure 66) Yo'dzonot Milpa Area	115
Figure 67) Settlement Zone, North of Cenote Yo'dzonot	117
Figure 68) Platforms at Yo'dzonot	118
Figure 69) South Side of Yo'dzonot's Structure N1W1-1	120
Figure 70) Hopemul, Location of Operation 1	122
Figure 71) Hopemul, Operation 1, North Profile	123
Figure 72) Hopemul, Operation 1, Initial Collapse	123
Figure 73) Ramonal Quemado, Location of Excavations	125
Figure 74) Ramonal Quemado, Operation 1, Level 2, Lot 1	126
Figure 75) Ramonal Quemado, Operation 1, East and South Profiles	128
Figure 76) Ramonal Quemado, Operation 2, Level 3, Lot 1	131
Figure 77) Ramonal Quemado, Operation 2, West and North Profiles	132
Figure 78) Ramonal Quemado, Operation 3, Level 2, Lot 1	135
Figure 79) Ramonal Quemado, Operation 3, North Profile	136
Figure 80) Ramonal Quemado, Operation 4, Level 3, Plan Map	139
Figure 81) Ramonal Quemado, Operation 4, North Profile	140
Figure 82) Ramonal Quemado, Operation 5, South and West Profiles	143
Figure 83) Ramonal Quemado, Operation 5, Level 2	144
Figure 84) Ramonal Quemado, Operation 5, Level 4	144

Figure 85) San Felipe, Location of Excavations	147
Figure 86) San Felipe, Operation 2, Bedrock	148
Figure 87) San Felipe, Operation 2, North Profile	148
Figure 88) San Felipe, Operation 3, Level 1, Wall	150
Figure 89) San Felipe, Operation 3, West Profile	151
Figure 90) San Felipe, Operation 3, Feature 1	153
Figure 91) San Felipe, Operation 4, Level 3, Lots 1 and 2	155
Figure 92) San Felipe, Operation 4, Southwest and Northwest Profiles	157
Figure 93) San Felipe, Operation 5, Level 3, Lots 1, 2 and 3	159
Figure 94) San Felipe, Operation 5, Southwest and Northeast Profiles	160
Figure 95) San Felipe, Operation 5, Feature 1, Consolidated	161
Figure 96) Location of Excavations at San Lorenzo, San Felipe	164
Figure 97) San Lorenzo, Operation 1, Level 3, Lot 1	165
Figure 98) San Lorenzo, Operation 1, South and West Profiles	167
Figure 99) San Lorenzo, Operation 2, West and North Profiles	169
Figure 100) San Lorenzo, Operation 2, Level 3, Plan Map	170
Figure 101) Pot, San Lorenzo, Operation 2, Level 4, Lot 2	171
Figure 102) San Lorenzo, Operation 3, Level 4, Lot 1	174
Figure 103) San Lorenzo, Operation 3, Northwest and Northeast Profiles	176
Figure 104) San Lorenzo, Operation 4, Level 3, Lots 1 and 2	178
Figure 105) San Lorenzo, Operation 4, South and West Profiles	180
Figure 106) San Lorenzo, Operation 5, East and South Profiles	182
Figure 107) Location of Excavations at Sisal, San Felipe	185
Figure 108) Sisal, Operation 2, North Profile	186
Figure 109) Sisal, Operation 3, Level 3, Lots 1 and 2	189
Figure 110) Sisal, Operation 3, Level 8, Lot 1 and Feature 1	192
Figure 111) Sisal, Operation 3, South and East Profiles	194
Figure 112) Sisal, Operation 3, Feature 1 Consolidated	196
Figure 113) Sisal, Operation 4, Level 3, Lot 1	198
Figure 114) Sisal, Operation 4, North Profile	198
Figure 115) Sisal, Operation 5, Level 6	200
Figure 116) Sisal, Operation 5, North Profile	202
Figure 117) Sisal, Operation 6, Level 1 and 2	204
Figure 118) Sisal, Operation 6, Level 2 and 3	204
Figure 119) Sisal, Operation 6, North Profile	205
Figure 120) Sisal, Operation 7, Level 4	208
Figure 121) Sisal, Operation 7, Level 5	208
Figure 122) Sisal, Operation 7, Level 6	210
Figure 123) Sisal, Operation 7, North and East Profiles	211
Figure 124) Sisal, Operation 7, Level 11	213
Figure 125) Surveyed Area, Ramonal Oriente, Sacalaca	215
Figure 126) Surveyed Area, Fortín of Yo'okop, Saban	217
Figure 127) Surveyed Area, Xnichteil-Yo'okop's Group C, Saban	219
Figure 128) Surveyed Area, X-Kancep-Ramonal (Saban)-San Pedro, Saban	220
Figure 129) Sketch Map of Ramonal, Saban	222
Figure 130) Sketch Map of San Pedro, Saban	223

Figure 131) Remains of Colonial-Historical house, San Pedro, Saban	224
Figure 132) Platform between X-Kancep and San Pedro, Saban	225
Figure 133) Surveyed Area, Ya'axche Tropical Forest	226
Figure 134) Mound at the Site of Ya'axche 2, Saban	228
Figure 135) Sketch Map of the Well of Chuunpich	233
Figure 136) Sketch Map of the Well of the Northeastern Group of Sacalaca	234
Figure 137) Sketch Map of the Well of El Palomar	236
Figure 138) Sketch Map of the Well of Ixbaquil	237
Figure 139) The Site of La Esperanza	239
Figure 140) Sketch Map of the Well of La Trinchera	240
Figure 141) Sketch Map of the Well of Parcela Escolar	242
Figure 142) Sketch Map of the Well of Ramonal Poniente	243
Figure 143) Sketch Map of the Well of Sahkabch'en	246
Figure 144) Sketch Map of the Well of San Andres	247
Figure 145) Sketch Map of the Well of San Diego	249
Figure 146) Sketch Map of the Well of San Isidro, Saban	250
Figure 147) Sketch Map of the Well of San Juan	252
Figure 148) Sketch Map of the Well of San Pablo	253
Figure 149) Sketch Map of the Well of Yaxche 1	255
Figure 150) Sketch Map of the Well of Yodzonot	257
Table 1) Ceramic Complexes into Cochuah Region	259
Figure 151) Middle Formative Ceramics: Tumben Incised and Uchben Incised Dichrome	263
Figure 152) Late Formative Ceramics: Laguna Verde Incised, Sierra Red, and Repasto Black on Red	264
Figure 153) Early Classic Ceramics: Xanaba Red and Dos Arroyos Orange Polychrome.....	265
Figure 154) Late Classic Ceramics: Arena Red and Sacalum Black on Slate.....	266
Figure 155) Terminal Classic Ceramics: Chum Unslipped and Muna Slate.....	267
Table 2) Ceramics of Gruta de Alux	268
Table 3) Ceramics of Hopemul	270
Table 4) Ceramics of Parcela Escolar	272
Table 5) Ceramics of Ramonal Oriente	274
Table 6) Ceramics of Ramonal Quemado	276
Table 7) Ceramics of Sahcabchen	282
Table 8) Ceramics of San Felipe	288
Table 9) Ceramics of San Lorenzo	300
Table 10) Ceramics of Santa Cruz	314
Table 11) Ceramics of Sisal	316
Table 12) Ceramics of Xbalcheil	336
Table 13) Ceramics of Xtojil	338
Table 14) Ceramics of Yodzonot	340

Part 1: Introduction to the 2010 CRAS Field Season

Chapter 1: Foci of the 2010 CRAS Field Season

Justine M. Shaw

Unlike earlier years, the 2010 CRAS field season focused primarily upon gaining more information on sites that had already been located (Figures 1 and 2). These efforts included both producing topographic maps of sites that had only been sketch mapped or briefly described, and excavating off-structure test pits at sites with little-to-no excavated sample. Additionally, limited surface collections were obtained from sites that lacked samples at which no excavations were planned for 2010. The overall goal was to better understand the nature of the approximately 500 sq km region's settlement patterns, the ways in which populations shifted through time, and, as possible, to seek correlates for the patterning.

As project members document more sites, as well as features visible between denser architectural clusters, it has become increasingly apparent that the concept of "site" has relatively little meaning. For project archaeologists, the term is problematic in that, as more and more of the terrain is observed in detail, it is difficult to find significant zones that lack features or artifacts. It is true that there are definite higher density architectural clusters, such as the components that make up the major centers of Ichmul, Sacalaca, and Yo'okop. However, it is difficult to even define borders for these major centers. Smaller settlements have been recorded with locations on the survey area map, yet these locations, like those of the larger centers, are misleading in that architecture is generally dispersed across the landscape intermingled with open areas, likely used for agricultural activities. In almost all cases, our "site maps" have, by necessity, been arbitrarily truncated when the end of a series of contiguous architectural features or some schedule-related time limit is reached, rather than by when no more architectural elements are visible in the vicinity.

Such a pattern makes us reconsider how the former residents of utilized their landscape; it seems quite likely that, with markedly different political systems, technology and transportation, and cultures, they would not have lived in the dense, year-round towns and villages that characterize the region today. Instead, as Alberto Flores and I discussed as we attempted to restrain ourselves and artificially truncate the mapping of yet another "site," it is probably much more realistic to think about a fairly fluid population that might have moved seasonally, to live near dispersed *milpas* during seasons requiring more intensive labor or to somewhat more concentrated towns and villages for social, political, and religious reasons at other times. Much like the bees that have recently abandoned part of our study area after several years of drought, residents also probably moved longer distances for reasons ranging from rainfall to the pull of charismatic leaders to the availability of trade goods. It is likely that the amount of mobility would have varied considerably from one period to another. Today, when a field house, residence that is distant from town, or beekeeping area falls out of use, its owners often leave ropes, buckets, hives, and other tools, with the idea of returning someday. Sometimes people do return, but other times the items are permanently discarded, to be quickly overgrown by vegetation and broken down by the elements.

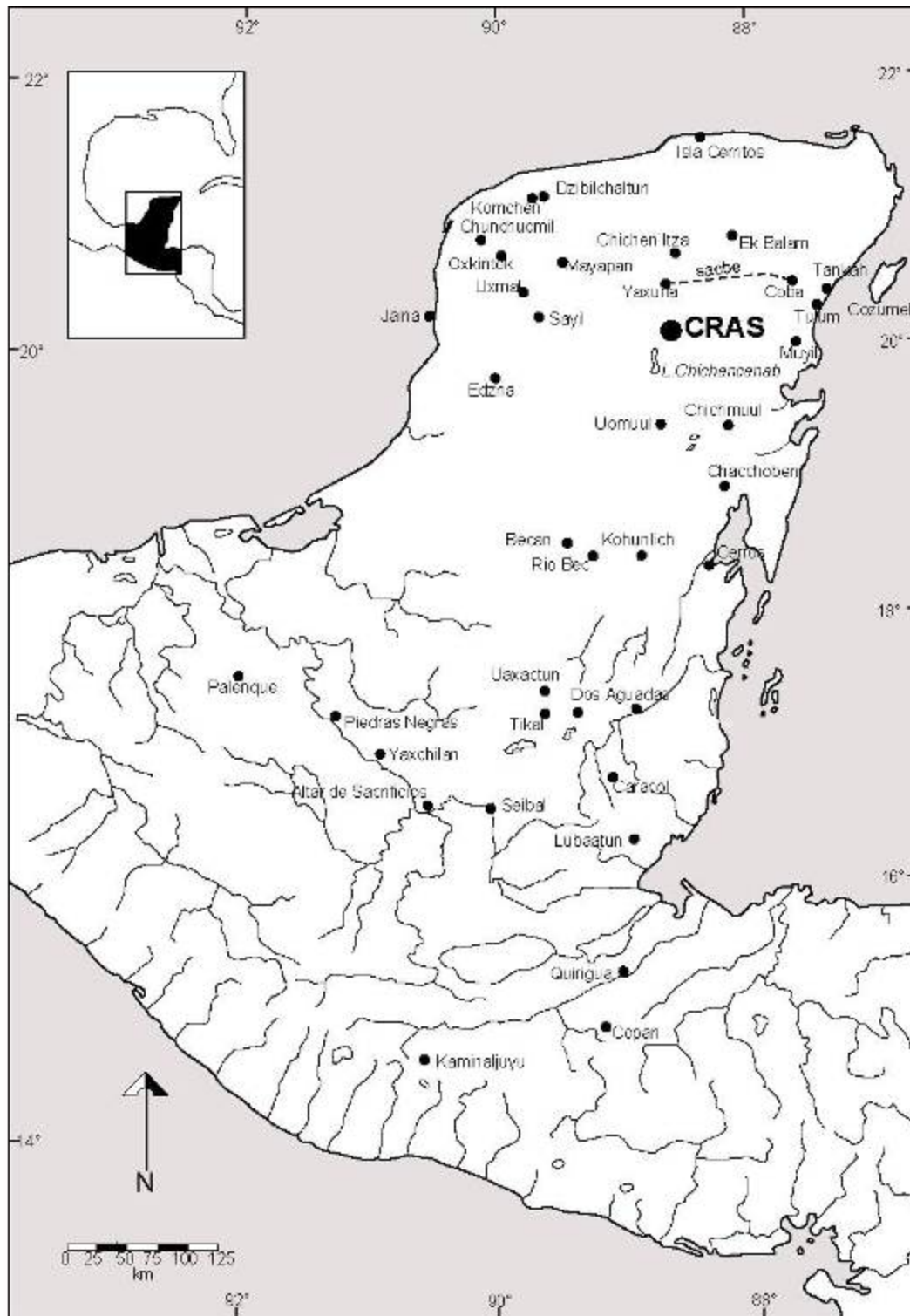

Figure 1. Location of the CRAS Study Area

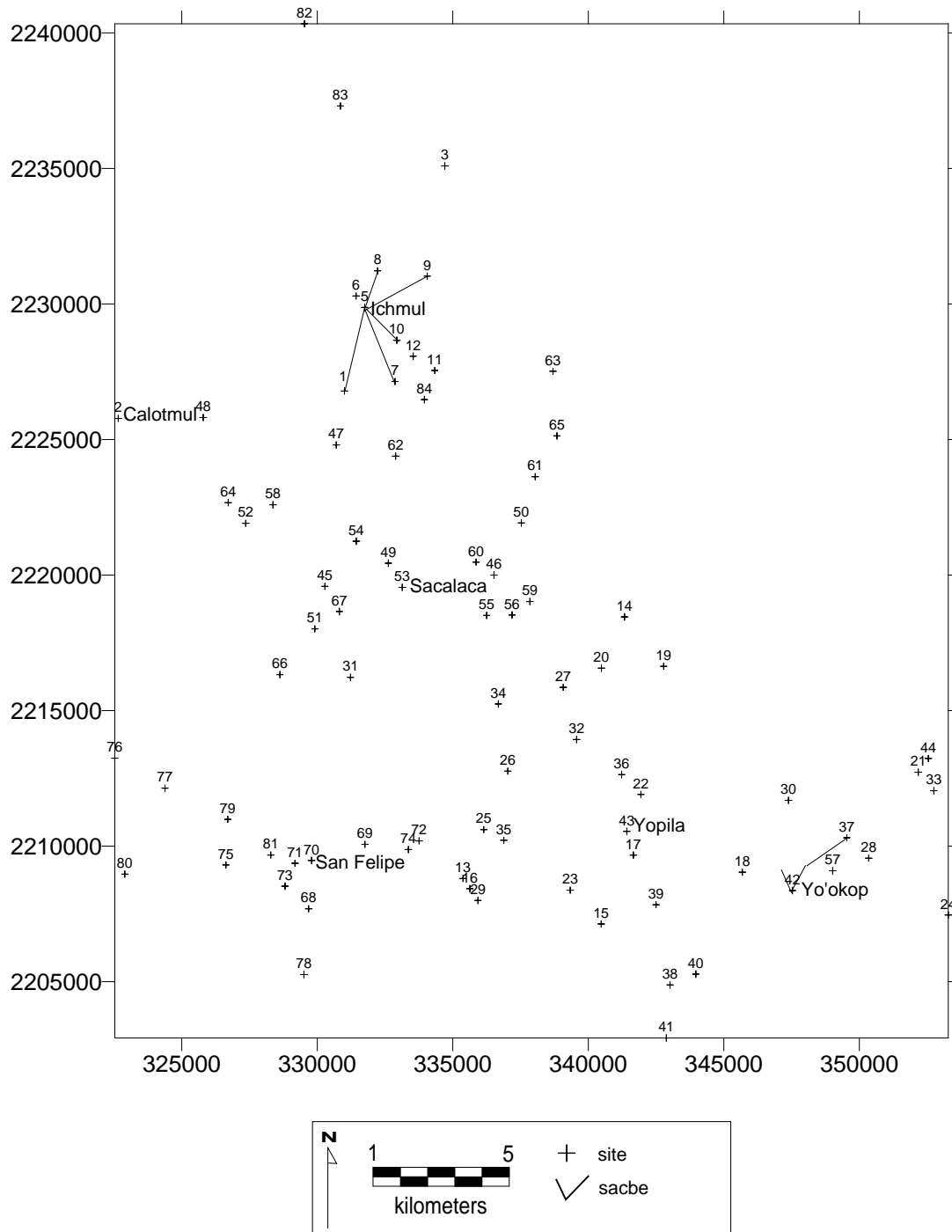

Figure 2. Sites within the CRAS Study Area
(Key on page 4)

Site	Name	Site	Name
1	Xquerol	43	Yo'pila
2	Calotmul	44	Ramonal
3	Chan Mahas	45	Aktun
4	Chikin Ichmul	46	Chakal Ja'as
5	Ichmul	47	Cortada
6	Poxil	48	La Esperanza
7	San Andres	49	Parcela Escolar
8	San Cristobal	50	Ramonal Oriente
9	San Juan	51	Ramonal Poniente
10	San Pedro Chan Ichmul	52	Rancho Guadalupe
11	X-ma-kabba	53	Sacalaca
12	Xbequil	54	San Andrés
13	Abuelos	55	Trincheras
14	Huay Max Aktun	56	San Diego
15	Balche	57	San Isidro
16	Chuun Katzin	58	San Juan
17	Chuun Pich	59	San Pablo
18	Fortín de Yo'okop	60	San Pedro
19	Gruta de Alux	61	Santa Cruz
20	Huay Max	62	Santa Elena
21	Kancep	63	Xbalcheil
22	La Trinchera	64	Xbaquil
23	Nenela	65	Xtojil
24	Palomar	66	Yo'aktun
25	Pancho Villa	67	Yo'dzonot
26	Rancho Rosales	68	Hopemul
27	Saban	69	Ramonal Quemado
28	Sahkabch'en	70	San Felipe
29	Sak Chikin	71	San Fernando
30	San Francisco	72	San Jose Sisal
31	San Isidro	73	San Lorenzo
32	San Manuel	74	Sisal
33	San Pedro	75	Candelaria
34	Santa Rita	76	Rancho Chankunai
35	Venadito	77	Rancho San Francisco
36	Xkanil	78	San Salvador
37	Xnigteil	79	Santa Elena
38	Yache 3 (x-Copó)	80	Tabasquito
39	Yaxche	81	Benito Juarez
40	Yaxche 2	82	Xlapak
41	Yaxche 4	83	Xnigteil
42	Yo'okop	84	Nohcacab

Figure 2. Sites within the CRAS Study Area (Key)

While the CRAS project has refrained from estimating population counts based upon structure counts, artifact frequencies, or some other arbitrary measure multiplied by guesses, we have long noticed that some periods are very well represented in the archaeological record based upon the commonality of sherds or diagnostic architecture visible from those periods. The Late Formative and, most of all, the Terminal Classic appear to be the periods of greatest occupation in the Cochuah region. We have been slower to locate significant Middle Formative, Early Classic, Late Classic, and Postclassic populations. It is likely that the Late Formative and Terminal Classic do, indeed, represent population spikes. However, we are beginning to consider the degree to which these peaks and valleys might also include factors such as mobility and our ability to recognize distinctive remains from each of these periods. Additionally, small sample sizes have also conditioned our impressions of occupations, as test pits from 2010 have produced more Middle Formative and Early Classic ceramics than might have been anticipated based upon prior excavations.

The problem of diagnostic architecture during the Postclassic is an issue that has only recently come to the attention of the project. For years, like others working in the region, we had documented Postclassic shrines and temples atop and adjacent to earlier constructions. Blaming the features on “pilgrims,” the assumption was that they surely lived elsewhere but had returned to the Classic sites for special purpose visits, not as residents. As project members have come to more intimately study more sites, including the smaller-scale, dispersed settlements, a late phenomenon of round foundation braces for perishable superstructures has become evident. In 2010, these features were documented and several and, adjacent to examples of this structures, excavations of test pits were conducted at Sisal and Gruta de Alux, sites previously documented in 2008.

Our growing intimacy with the Cochuah region has certainly provided us with a much better understanding of settlement dynamics than we had just a few seasons ago. However, with each season, our increased knowledge has also resulted in more questions to be investigated in the future.

Part 1: Introduction to the 2010 CRAS Field Season

Chapter 2: CRAS Research Methods

Justine M. Shaw

The 2010 Coahuah Regional Archaeological Survey (CRAS) involved archaeological research of the *ejidos* of Saban, Sacalaca, and San Felipe. As the sites included in the survey area had received only cursory from archaeologists in the past, it was determined that CRAS should perform basic documentation on the largest architecture and main plazas at each site, with surrounding smaller features included as time permitted. For this reason, investigators made use of local consultants as their primary means to locate sites and features. Since the local Maya have been utilizing their territory for *milpas*, hunting, and procuring natural resources throughout their lives, most adult men are able to readily report the location of *montículos* (or *mulob*). Such features are generally at least 3 m tall, decidedly skewing our sample. However, archaeologists made an effort to record the existence of adjacent smaller constructions in all zones that were mapped in detail.

A number of Global Positioning Systems (GPS - Garmin Colorado 300 and Garmin etrex) were used to locate the modern *pueblos* and archaeological sites within the region. More detailed mapping was done using a Topcon GTS-213 total station with a TDS-48 data collector operated by the principal investigators and/or other archaeologists. Topographic relief, as well as any *in situ* archaeological elements, was recorded. The resulting maps are presented with a 50-cm contour interval (unless otherwise noted) in order to display some subtle terrain changes. Crews from each *ejido* were hired to clear all features to be mapped and to help locate features. Due to the structure location procedure, mapping generally began near a large mound and proceeded to the surrounding territory as time permitted. Data on each point (recorded as coordinates N, E, and Z relative to the site datum, as well as with a descriptive code and notes) were saved on the data collector and then downloaded onto a laptop computer each night. Using Surfer (version 8.0), maps were generated daily to allow ground-truthing. This strategy permitted maps of the documented regions to be prepared and given to INAH-QR and local authorities at the time the field season was completed.

Numerous 2x2 m test pits were undertaken in the plaza(s) of several of the sites investigated this season. These plaza area excavations were aimed at providing ceramics from sealed contexts that could be used to date the sequence of constructions in a given area, as well as to determine the number and characteristics of such plaza flooring and occupation episodes. Test pits were excavated in cultural levels and concluded at bedrock unless otherwise indicated, with materials separated according to the operation/ level/ lot system. All fill was removed using small hand picks and trowels, transferred to buckets, and then screened using 1 cm mesh. Shaw or Johnstone monitored each excavation, which was under the immediate direction of one or more of the Project's experienced archaeologists. One to three local crew members assisted

with the excavation and screening. All test pits were backfilled upon completion of the excavating and recording process.

Some surface collections were obtained from sites without excavated samples. Ideally, these were collected from cleaned 2x2 m areas. However, when time and/ or vegetation cover inhibited this methodology, less formal means were employed, such as picking up all the ceramics visible in leaf-cutter ant trails. In either case, all of the sherds and other artifacts, regardless of size or quality of preservation, were collected.

Artifacts from the excavations and surface collections were washed and marked with the site, operation, level, and lot. The Project utilized digital photography, plan and profile maps, and extensive note-taking to record remains visible on the surface and in excavations. Sherds were identified to the variety level whenever possible, using the type-variety system (Smith et al. 1960).

At the end of the season, maps and preliminary summaries were presented to local authorities so that interested individuals could begin to see the products of our research as soon as possible. Spanish-language versions of the completed report will be delivered to the *ejidos* in the future. English and Spanish versions of the report will also be available on the project's web page.

Part 2: The *Ejido* of Saban

Chapter 3: The Site of Abuelos

Johan Normark, Pablo Huerta and Dave Johnstone

The site of Abuelos is located 8 km southwest of the church in Saban (Figure 3). The cave at the site has a steep slope down to a short passage with only one Terminal Classic sherd spotted, but not collected, on the cave floor. Near the cave is a fairly large *sascabera*. Next to the *sascabera* there is also a *chultun*.

Only three structures were mapped at the site and they are located roughly 100 m northeast of the cave. The southernmost structure, N1W1-1, consists of a round substructure and a round foundation brace on top. A small rectangular foundation brace, N1W1-2, is located directly north of it. Slightly higher up in the topography is a small platform and a foundation brace with the entrance to the south, N1W1-3.

North and east of these structures are other unrecorded buildings. At least one of them is roughly three m high. This area shows a fairly low settlement density compared to the sites directly to the west in the *ejido* of San Felipe, such as Sisal. Hopefully the map can be extended to these other buildings in the future.

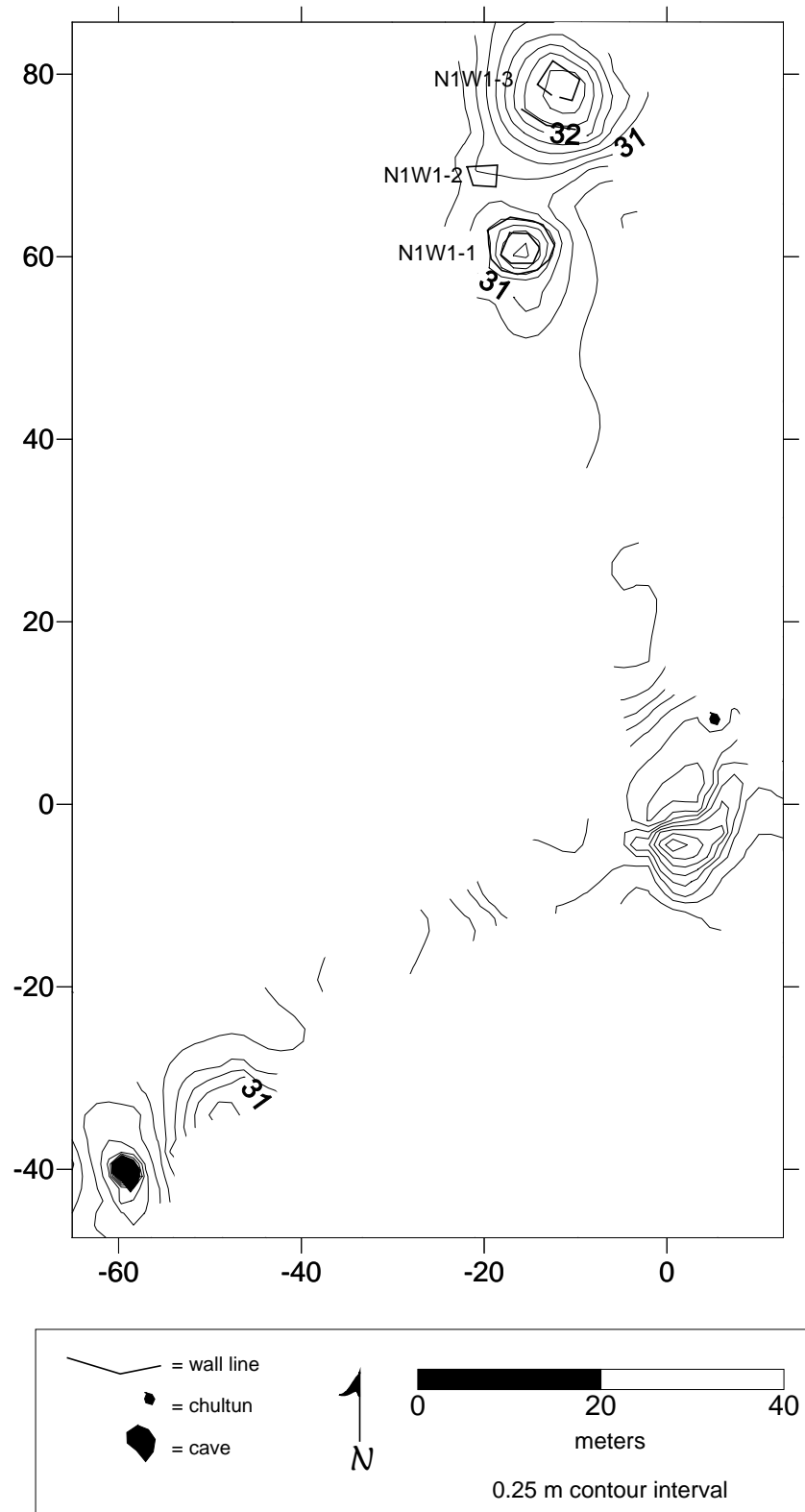

Figure 3. The Site of Abuelos

Part 2: The *Ejido* of Saban

Chapter 3: The Site of Chumpich

Bryce Davenport, Alejandra Badillo, and Justine Shaw

The site of Chumpich is located in the *ejido* of Saban, and was plan-mapped during the 2008 field season (Flores Colin and Huerta Rodríguez 2008). This previous map covered some 400 sq m, with visibility greatly aided by recent *milpa* burning. However, during the 2010 season visibility was poor, and the project was only able to map some 40 by 80 sq m with a transit (Figure 4). Although a relatively small portion of the previously surveyed area was recorded, the settlement pattern at Chumpich serve as a microcosm for many of the features encountered during the Coahuah Regional Archeology Survey.

The principal feature of Chumpich is a colonial- and modern-era well, situated approximately 2 m adjacent to the modern trail that runs north-to-south through this portion of the *ejido*. The lower elevation of the well in addition to the presence of Prehispanic structures in the area suggests that it existed as a geological formation prior to Spanish contact and was not drilled during colonial times. The well is still in active use today.

Approximately 25 to 30 m northeast of the well lay two terraces built into the natural rise of elevation that occurs on a south-to-north gradient. The artificial faces of the terraces are between 50 cm and a meter in height. Moving north, bedrock appears within 2 to 3 m of the initial terrace surface. The northern terrace contained two rectangular foundation braces (Structure N1E1-1 and Structure S1W1-1), possibly Terminal Classic domestic structures, and debris that appeared to be wall collapse. The eastern terrace held numerous alignments that may possibly have also been foundation braces as well a circular foundation brace (Structure S1E1-1). Circular foundation braces have been reported in earlier CRAS field seasons (e.g. Normark 2008: 44), and a possible interpretation is that they belonged to Postclassic domestic structures.

Much of the hypothesized debris from both terraces appears to have been reused to build the *albarrada* that follows the terrace faces for approximately 60 m before forming a right angle and cutting across the surface of the eastern terrace. Two modern posts were found immediately adjacent to one of the alignments on the eastern terrace, both showing evidence of burning that presumably was associated with a *milpa* clearing event. To the south of the terraces, a modern shelter used to cultivate nearby beehives was associated with loose stone taken from the nearest portion of the *albarrada*.

While Chumpich appears to be a minor site, it demonstrates the central importance of water sources in settlement patterns, continuity between Prehispanic, colonial, and modern settlements, and the active economic cycling of Prehispanic resources such as building stone. The circular foundation brace appears to be constructed in part from an earlier rectangular brace or other alignment, making this site

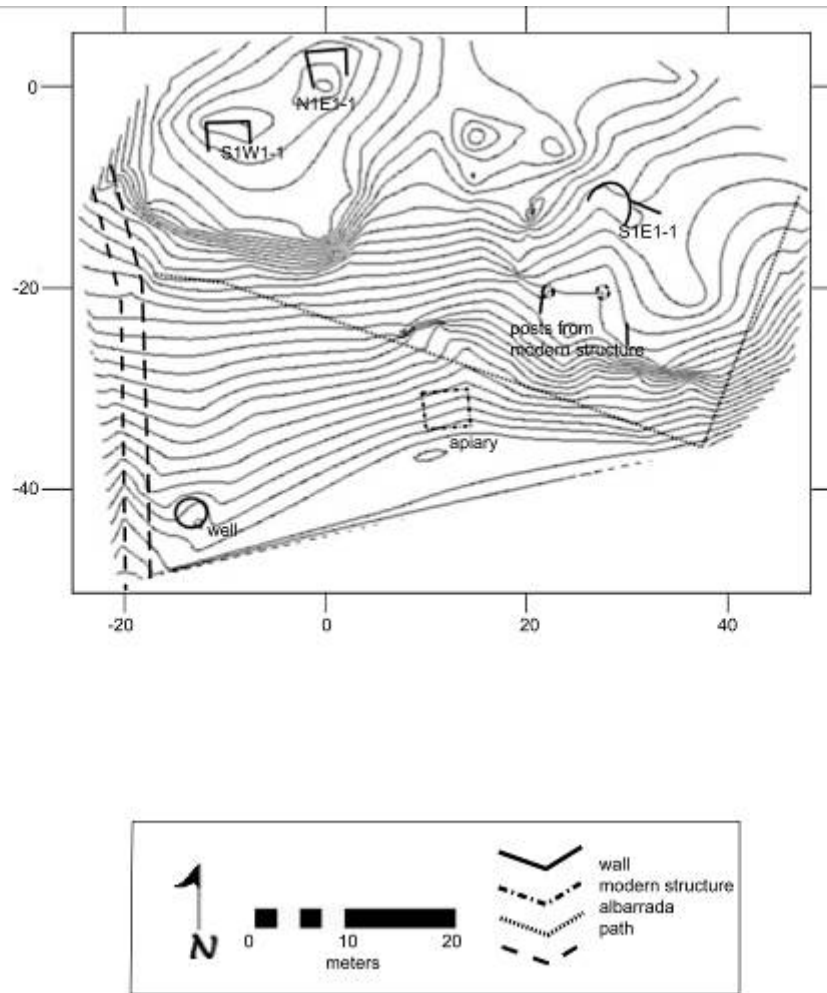

Figure 4. The Site of Chumpich

less than ideal for testing the temporal associations of the different construction methods. However, further evaluation of the wells chronology is vital, as one of CRAS' principal aims is to understand water management outside of the Yucatan peninsula's *cenote* zone.

Part 2: Ejido of Saban

Chapter 5: One Space, Two Places: The Maya and the Military:
A Constructed Landscape in the Northwest Region of Yo'okop

Alejandra Badillo, Bryce Davenport, Justine M. Shaw, and Alberto G. Flores

*“We are in a strange part of town:
In time we know a few landmarks [...] eventually what was a strange town and unknown space becomes a familiar place”*

SPACE AND PLACE,
THE PERSPECTIVE OF EXPERIENCE
Tuan 1977

According with Yi-Fu Tuan, *space* is abstract, unprovided of meaning when is unconnected. However, it becomes a *place* when is interpreted, when it acquires a specific meaning (Tuan 1977:3, 200).

Humans plan and transform space both physically and socially, transformations that leave a trace in the constructed landscape. The northwest region of Yo'okop, a region with unexpected relief and water sources (with the largest *aguada* in whole region), and characterized by vestiges of a dissimilar past, ranging from the ancient Maya cities to the other military constructions of the Nineteenth Century. Vestiges that, despite sharing the same location, had developed different places and generated contexts and functionalities that are totally opposed. With different historical dates, both complexes produced different behaviors and conduct in the social groups that settled in this area. These two places had contrasting meaning and representations throughout time, based upon diverse ideologies.

Natural terrain, as well as the rocky material of this region, and furthermore the intentions of the social groups – both ancient Maya (since the Late Formative until the Postclassic) and the Mexican military (during the Caste War) - were decisive in the transformation of the space in the northwest region of Yo'okop, both in different periods, defining the configuration of constructed landscapes. The latter group, unfamiliar with the space, confronted with the tropical forest said that it “ha desarrollándose, borrando hasta las señales de camino; y para llegar al corazón de la comarca rebelde, se tiene que atravesar bosques desiertos, tan cerrados, que la vista no penetra en ellos sino en un reducido radio de ocho a diez metros” (México Militar 1901e:19). The military mentioned that, to transit through this region, it was necessary “abrir la senda, se tiene que barrenar entre la maraña que forma la selva bravía, y hay necesidad de, por medio de cálculos geográficos, dirigir tales sendas para llegar a los pocos puntos conocidos por noticias más o menos acertadas”. Military advance depends upon “aguajes [natural water pools] por lo que se hacía aún más difícil la empresa de avance”, without this substantial liquid, those men have been died by thirst (México Militar 1901e:19).

The military campaigns, gradually, were appropriating and giving a new meaning to this space of the northwest region of Yo'okop, a region that was one of the main

scenes of the Caste War. According to the *México Militar* magazine from the early Nineteen Century, “una avanzada militar llegó a Okop, en donde el C. General Ignacio Bravo, jefe de campaña contra los mayas rebeldes, decidió construir dos fortalezas pensando en que pronto iniciarían los encuentros con los mayas rebeldes” (*México Militar* 1900a:195).

This is the current context that can be seen in the region, which is the subject of this investigation.

During July of 2010, the sites known as “Fuerte de Yo'okop” and “Fuerte de la Loma,” located two kilometers northeast of La Aguada, and the Prehispanic Yo'okop, were documented. In accordance with the main goals of the CRAS Project, to locate and register all the possible remains of varied periods, and explore the relationship between them, the context of this micro region of Yo'okop is an excellent and complex example for this investigation.

For that reason, the field work in 2010 was focused upon conducting a topographical mapping of both the fort next to the road (Fuerte de Yo'okop) as well as the fort on the high area (*fortín* or *fortalice*).

Mapping was conducted by Justine Shaw, Alejandra Badillo, Bryce Davenport, and Alberto Flores, always assisted with local workers and consultants from the *ejido* of Saban.

After a quick survey of this landscape, it was hypothesized that both military fortifications were constructed with/ upon Prehispanic structures and terraces, as will be explained in the following pages. But, we should begin with the antecedents of Yo'okop. The site was reported by Mason and Spinden in 1927. In 1954, Stromsvik, Pollock, and Heinrich visited and reported upon Group B and its connection with Group A through a *sacbe* (raised causeway); furthermore, they conducted an extensive survey and produced sketch maps of several sections of the site. In 1966, Jack Walker and Reginald Wilson visited the structures that surround La Aguada and Group A. Three years later, a pilot, Bill Clapp, located Groups A, B and C, as well as Sacbe 1 and 2, and three stelae. Until 1972, Walker y Wilson got information about the main groups and carried out measurements of the structures. From that date until 1998, no other exploration was conducted. Martos and Rodríguez (1998) carried out a survey and excavation of the historical Fort of Yo'okop, as well as other sites of the Caste War, such as Lalcah, Xcolumpich, Hacienda de los Arcos and Halal Hacienda. Also, a plan map of both fortifications at Yo'okop was generated. Shaw and Johnstone, between 2000 and 2002, conducted a topographical registration and carried out excavations and data analysis of several areas of this settlement. During those seasons, Groups A, B, and D, as well as Sacbe 1, Sacbe 3, and a section of Sacbe 4, were mapped with a total station. This map of the major architecture was completed in 2008, when Grupo C and Sacbe 2 were recorded (Shaw and Johnstone, 2000, 2002 and 2008).

Based on this corpus of data is possible to consider this settlement as a Rank 1 site, showing a pattern of “beads in a string”, where Group A is connected though Sacbe 3 with Group D, while Sacbe 1 links Group A with Group B. From the latter group, another causeway (Sacbe 2) begins, running north to Group C (Figure 5). In general, all the areas between these groups should be full of other structures that have not been investigated yet. Such structures could include vestiges from Prehispanic times to the Caste War (Shaw and Johnstone, 2000, 2002, 2008), as is the case of the Fort of



Figure 5. Satellite image of Yo'okop (including architectural Groups, La Aguada, and, to the northeast, the region with the Nineteen Century constructions)

Yo'okop, where ancient remains were covered with latter constructions (from the Twentieth Century).

As has been mentioned before, Caste War fortifications were investigated by Martos and Rodríguez (1998). These investigators produced a plan map of both forts, furthermore describing architectural features such as ramps, walkways and excavations. These efforts also included an exploration of the northeast bastion, a midden into the west wing, and the southern area, where a series of ovens is located. Additionally, they tried to locate a supposed subterranean tunnel or communication system between two forts. This report also includes detailed descriptions and measures of the constructions. Information is available in Martos (1998) and Martos and Rodríguez (1998).

But, who inhabited these forts and why had they chosen this location? Historically, this region, formerly dominated by the Maya, was, by the Nineteenth Century, invaded by Mexican militia, in a conflict that included Maya rebels, who were tired of abuses and repression¹, and military, who were sent into a war that nobody wanted.

The war began in 1847, when the peninsula was separate from the rest of the Mexican Republic. The social context of this period was characterized by a series of conflicts, such as the United States invasion around 1847 and 1848. By this time, the war in the peninsula was increasing, and Maya rebels dominated two-thirds of the Yucatecan territory. They were led by several leaders – in the beginning - Antonio May from Chihimilá, Cecilio Chi from Tepich and Jacinto Pat from Tihosuco. When they were defeated after a while, new leaders reappeared. By August of 1848, the territory of Yucatan was reincorporated with Mexico after obtaining military reinforcements, in order to finish the war. But, despite these plans, a resurgence occurred with the Cruz Parlante (Talking Cross) phenomenon (by 1850-1852), that encouraged the Maya rebel movement struggling for freedom and autonomy; they called themselves the *cruzob* (the crusaders). Officially, the end of the Caste War was declared by 1855; however, conflicts continued for several decades.

Meanwhile, in the politics of the central Mexican Republic, two opposite groups, conservatives and liberals, competed for power, resulting in the Guerra de Reforma (Reform War) in 1858. Following this, the French Invasion occurred (1862), supported by the conservative groups and ending in the placement of a new monarchy named the Second Empire of Mexico, ruled by Maximiliano from Habsburg, who received the crown in 1864. Conflicts between liberals and conservative groups resulted in the toppling and execution of Maximiliano by 1867. With this action, there began a historical period known as the Restoration of the Republic. In Yucatan, meanwhile, the Maya continued with sporadic attacks until early Twentieth Century, mainly in the areas around Chan Santa Cruz (now known as the town of Felipe Carrillo Puerto), Bacalar, and the Rio Hondo region (Reyes B. 1902:238).

In Mexico City, Porfirio Díaz governed the country (Villalpando and Rosas 2003), under a positivist ideology and under the principle of “order and progress,” which intensified the repression against the insurrections of several groups, such as the Maya

¹ Of the governor Miguel Barbachano, who disposed their lands and imposed a repressive law of work, obligatory military service, high taxes (both civil as ecclesiastic), as well as by the untrustworthy promises of other politicians (Casares, 1998:191-195).

in Yucatan and the Yaquis in Sonora. By this time it was argued that “al concluirse la campaña contra los indios rebeldes de Yucatán, no habría en el territorio del país obstáculo alguno para la marcha de progreso en que con tantos alientos México avanzaba. La grande obra del eximio General Porfirio Díaz, habrá quedado perfeccionada, y la Nación dispuesta a las hermosas etapas del porvenir” (México Militar 1900B: 246). “Pues la vigorosa mano de Gobierno actual de la República, no podía ni puede consentir un solo palmo de su territorio extraño o ajeno al dominio de sus leyes. Necesitaba someterlos, y por ello emprendió una campaña militar” (México Militar 1901e: 17). In this regard, the Division General Bernardo Reyes, said: “A fin de acabar con la situación anómala y de barbarie y ocupar todo el territorio donde se hallan establecidos los rebeldes, el C. Presidente de la República [Porfirio Díaz] ordenó se diera principio á operaciones de aproximación por nuestras tropas, para lo cual fue preciso hacer con tiempo estudios geográficos y exploraciones diversas para formalizar una campaña, enviando fuerzas competentes por Peto, Iturbide de Campeche, la Bahía de Chetumal y otros puntos, y preparando, además, una flotilla para ayudar á las operaciones por el Oriente de Yucatán y dicha Bahía”(Reyes, 1902:239).

It was in this context in which the Caste War developed in Mexico. For the case that concerns us, we will focus in the last years of this conflict, during which military campaigns in Yucatan that covered several battlefronts were conducted. General B. Reyes narrates “Las fuerzas que se hallan en el centro del Estado, partiendo de Peto con dirección a Chan Santa Cruz, están á las órdenes del General de Brigada Ignacio A. Bravo [jefe de militar de la zona desde 1899], operando, en combinación con ellas en la parte oriental, las fuerzas que mandaba el General Rosalío Martínez, y que han quedado después á las órdenes del General de Brigada José M. de la Vega” (Reyes 1902:239). The line commanded by General Ignacio A. Bravo from Peto, with the main objective of taking Chan Santa Cruz, covered a region where several villages are located, including Dzonotchel, Ichmul, Saban, Okop, Chuncacab, Santa Maria, Hobonpich, Tabi, Nohop, Sabacché, among others. It is relevant to say that the aforementioned Okop, is the modern Fuerte de Yo'okop, the subject of this study, formerly known as Fuerte Militar No. 7 (Figure 6). In the east, were the military formations of the Ascension Bay led by Lieutenant Colonel Téllez Girón, who had at his disposal the warship “Zaragoza”; to the north lay the line of communication from Puerto Morelos to Valladolid, while to the south a military line was located where General Vega cut the enemy route to the Bay of Chetumal, Rio Hondo and Bacalar (México Militar, 1901c: 509).

The position of the government forces was planned to lead the troops into enemy territory. General Ignacio A. Bravo for his part established seven forts from Okop to Peto, plus outposts (A, B, C, D) to Hobonpich, which can be seen in the figure showing the sketch entitled “Theater of War” (Figure 7). In that respect, Reyes states “Las fuerzas del General Bravo cuentan con los elementos necesarios para abrir campaña, teniendo su base de operaciones en el Puerto de Progreso y en Mérida; su defensa á vanguardia, en los fuertes de Petó á Okop, y campos retrincherados hasta Hobonpich; disponen de una ferrocarril desde Progreso á Peto y de más de 180 mulas para transporte, del punto final del ferrocarril á vanguardia. Su comunicación con los

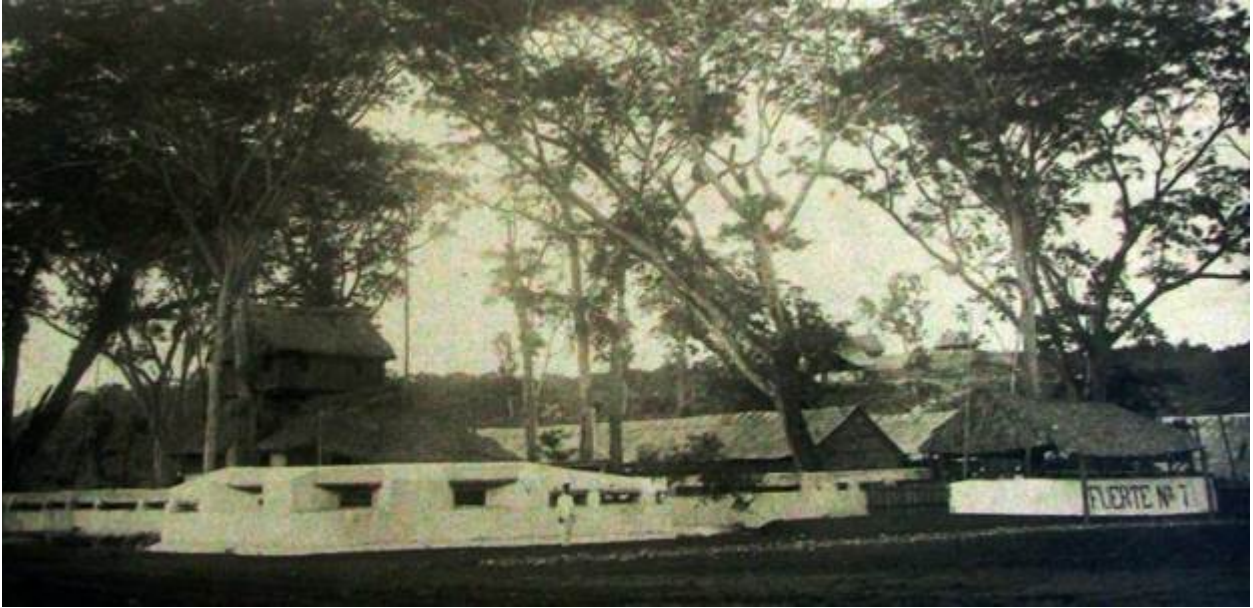

Figure 6. Okop Fort No. 7 (actually known as Fuerte de Yo'okop. Shows the west facade in the foreground and left the north side. Photo album of the campaign of General Bravo in 1901, from Library Cresencio Carrillo y Ancona in Mérida)

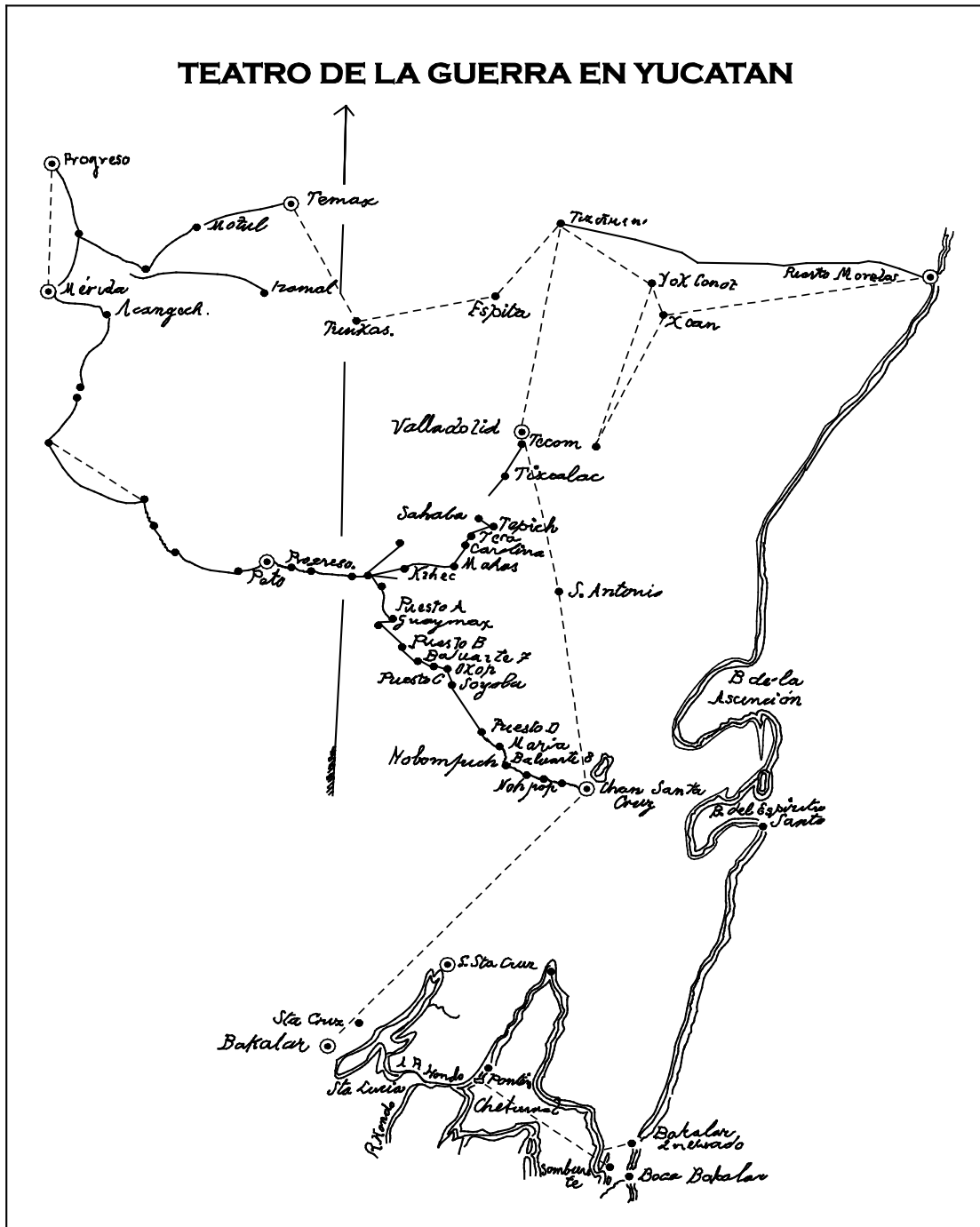

Figure 7. Fort of Yo'okop, Bastions 7 and 8 (Sketch map of fortifications and military positions A, B, C and D, besides Bastion 7 and Bastion 8 [Fort of Yo'okop]). The map locates the buildings mentioned in the vicinity of Balche, Saban Soyolá, Cuncab, Okop and Hobompich, respectively. Redrawn from México Militar, 1901c: 509)

destacamentos de Carolinas, Valladolid y Chemax, es telefónica, y en el resto, hasta la Capital de la República, telegráfica, del Puerto de Progreso tienen transportes por mar, que, cruzando hasta Veracruz, hacen la travesía en 50 horas por vapor y en doce días con vela (Reyes 1902: 248). The extensive knowledge and exploration of the territory in dispute, in addition to those lines of communication with the troops that had Yucatan campaign, can be observe in the map produced for military purposes entitled "*Sketch of Yucatán, formed in the presence of acquired data by the special corps of the Estado Mayor*" presented by B. Reyes in his war memoirs in 1902.

In addition, the construction of forts required a selection of space considered "la más apropiada, es la que natural y fácil se ofrecía geográficamente en todas direcciones, contra el enemigo, puesto que el territorio nacional encasquilla y ciñe al suyo." They said that the choice of a place is what could make the operations difficult; however, sometimes "saltaba a simple vista la que, de preferencia a cualquiera otra, hay que elegir" (México Militar 1901e). They sought highlands with good visibility, both to defense as well as for attack.

General Ignacio A. Bravo organized his troops to look for locations that would serve as fortifications, as well as to advance these, in the following manner: "mandaba al frente perros; luego a exploradores, más atrás, a sus líneas de combate," which were advancing along paths made by hundreds of workers who opened up the vegetation, roads of 100 to 150 meters, even up to 300 meters, wide. With every advancing step, troops had to "...asegurar con [guarniciones correspondientes] fortificaciones [y] cuanto iban dejando a retaguardia, y que dar fuerza de seguridad al camino que iban practicando, para que les puedan ser llevados, según avanzan, cuantos víveres y municiones necesitan..." In the end "... a retaguardia [se unía] la tropa en formación, y la tropa que se comunicaba con el último campo atrincherado o fuerte del cual se partía, y que llevaba consigo su artillería" (México Militar 1901: 409, 410).

Strategies like this were carried out in the Campaign of Yucatan in the late nineteenth century, under the leadership of General Bravo, who was told that he "ha ido ejecutando sus trabajos de aproche, estableciendo fuertes a distancia, que no exceden nunca a diez kilómetros y así ha podido penetrar 20 leguas en la comarca enemiga." He raised seven military forts, in addition to well entrenched fields from Peto to Chan Santa Cruz, on both plains and hills along the road (Figure 8). Each military construction communicated with the previous one, and its function was determined by the fact that the "...vía principal de transporte era el ferrocarril que de Peto llegaba a Puerto Progreso donde se recibían en buques, todos los elementos necesarios para la misma." The General had the good sense to settle in certain areas in which telephone and telegraph service had advanced; these services were used to maintain constant communication with the general telegraph network existing in the Republic around late nineteenth century (México Militar 1901: 409, 410).

The forts were defensive points in the road "los ocho fuertes fueron establecidos en lugares apropiados, siendo el último el de Hobompich, a 45 kilómetros de Chan Santa Cruz. Todos tienen la guarnición necesaria para su custodia, y así las fortificaciones como las tropas que las ocupan, se aumentarán ó disminuirán según las necesidades de la campaña" (Reyes 1902: 239). Gradually, the General Ignacio A. Bravo was carrying out his march "con todas las precauciones que demanda aquella

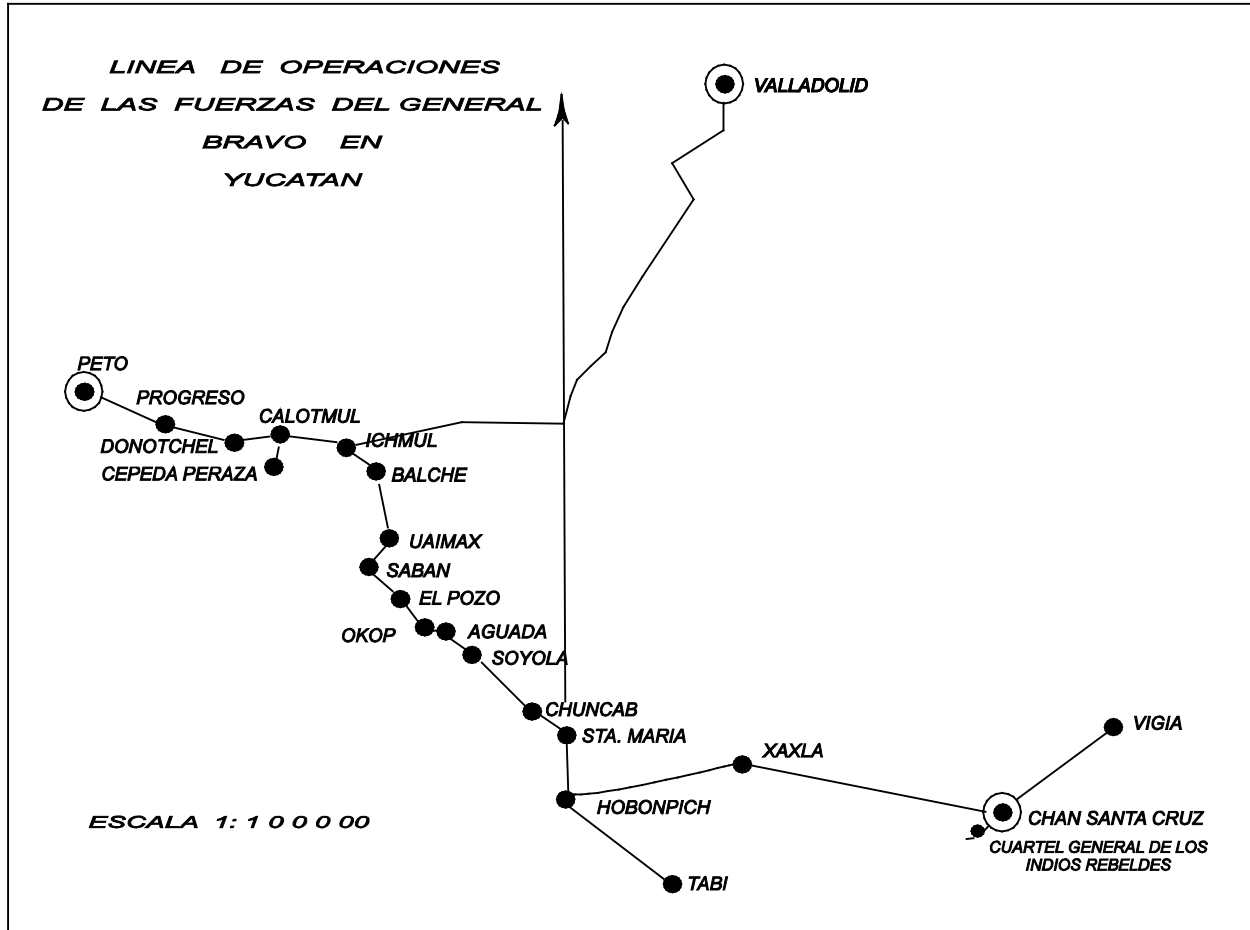

Figure 8. Sketch Map of the Operation Lines of General Bravo's Forces in Yucatan. Redrawn from México Militar 1901: 410.

guerra, y ejecutaba los trabajos de apertura de vía, así como el establecimiento de campos atrincherados" (México Militar 1901d: 439). These fields, in which his scouts lay covered, to exchange fire with the Maya rebels. An early twentieth century magazine (México Militar) mentions that attacks were carried out three times in a fortnight; they had skirmishes but these had not been enough for hundreds of Maya rebels to stop federal troops that, nevertheless, continued their advance. The military column of the General continued on foot to Tabi, a position that was conveniently fortified, and the Fort of Okop (Yo'okop) was left behind (Mexico Military 1901d: 439 and 1901: 409, 410). Regarding to the above mentioned, General Bernardo Reyes wrote that "Hasta la fecha han ocurrido veinte encuentros con los mayas. Las pérdidas de nuestras fuerzas han consistido en once individuos de tropa muertos, y dos Oficiales y sesenta y un individuos de tropa heridos. El enemigo tuvo muchas bajas, y fue derrotado en todos los combates, aun en los que libró al abrigo de fortificaciones y en número de mil hombres, como sucedió el 18 de Mayo de 1900 cerca del punto llamado 'Santa María'" (Reyes 1902: 240).

Having extended the telegraph line and without having more encounters with the Maya, the military continued their advance towards Nohpop, where they formed the last entrenched field, " habiendo quitado dos veces sus parapetes al enemigo, ha seguido su laborioso avance, hallándose a virtud de esa marcha, a seis o siete leguas Chan Santa Cruz, punto objetivo a que se dirige." The General planned the final moves to take the town of Chan Santa Cruz, taking into account that "los alrededores [de dicho poblado], el monte es más abierto, [por lo que] el avance, podrá hacerse con menos lentitud" (México Militar 1901b: 482). Federal troops formed detachments to cover the lines of communication and protect the seven forts and garrison outposts along a line twenty leagues long and two hundred meters wide, opened by General Bravo, that continued to advance. The General had several battalions available, watchmen, a battery, a division of cavalry, a complete telegraph setup, transportation and health services, and a total of 3,000 men, while the Maya had only 2,200 men, of whom 700 guarded their positions and 1,500 formed their own defensive row. This military strategy intended to leave no escape for the Maya *Cruzob*, closing all retreat to capture them in mass and, thus, terminate the war. Otherwise, it would degenerate into a guerrilla warfare and persecutions (México Militar 1991e: 17).

Authors like Reed (2007) state that each village through which this military advance of General Bravo's troops passed (Tabi, Nohpop, Sabacché and even Chan Santa Cruz) was evacuated and the refugees fled to the north or south of the Yucatán Peninsula. Therefore, when federal forces arrived, many villages did not offer any resistance. Reed says that gradually Maya Cruzob troops were diminished by these attacks, as well as an epidemic of mumps; hence the villages were abandoned to the extent that in early May 1901, when the troops of General Bravo arrived in Chan Santa Cruz, they took the town without any resistance (Reed, 2007: 235, 237). From a military standpoint it was said that on the outskirts of Peto and heading to Chan Santa Cruz, the entire population had disappeared, swept away by the Indians. The roads no longer existed, since the vegetation had covered them and, therefore, the progress of the troops had been delayed by the necessity of opening up new roads, establishing fortified camps, digging wells and cleaning up a few water sources that were still usable. This advance, although relatively slow, had been safe, and the troops did not suffer from

lack of water or accommodations. They had taken the completed part of south-eastern railway, until the town of Peto, and from village to Saban (at 42 kilometers) they had already done the study, grading, and location of the road (Reyes 1902: 239).

It was in 1901, during the Porfirio Diaz government, that the increase in shipments entering through the Yucatan Coast put an end to the Caste War. This was influenced by the systematic advance of General Ignacio A. Bravo and his troops, through Dzotonchel, Sacalaca, Calotmul, Ichmul, Balche, Saban, Okop, Chuhcab, Santa Maria, Tabi, Nohpop, Sabacché and Chunkik until they took Chan Santa Cruz on May 4, as well as the advance, through the sea, of the troops of General Vega, who occupied the Rio Hondo the boundary of the British colony of Belize, with his fleet, took possession of Santa Lucia, and then proceeded towards Bacalar. This settlement was evacuated by the Maya and occupied by the military at the end of the aforementioned month (Reyes 1902:239) (Figure 9).

The Caste War was a social movement that persisted for 54 years, led by Maya that fought against the oppression and marginalization that they were victims of in the nineteenth century. The history that we know of this event was told through the voices of Maya and military of that time, in addition to the historical and ethnographic investigations about subjects that participated in that war and/ or their descendants. This social conflict left tangible traces in the eastern portion of the Yucatan Peninsula; the environment was transformed in order to benefit those involved. Spaces were modified, buildings were erected, roads were charted, and social landscapes were constructed. The military configured places with new senses and meanings as a result of determining social context, evidence that demonstrates the days of fighting.

Today, is still possible to observe several modifications carried out by the military during the Yucatan Campaign conducted by General Ignacio A. Bravo, including how they took advantage of natural sources and ancient Maya sites offered in the route between Chan Santa Cruz and Petó, which they used to built forts and trenched fields. In that months and days of General Bravo's campaign, troops had to cut down several miles of forest and construct emplacements in order to advance into the region. When they reached the site formerly known as O'kop (today known as Yo'okop), which means in Yucatec Maya "valley between two mountains," Bravo's troops deployed a military complex that consisted of two forts (located about 2 km northwest of La Aguada, the largest catchment of fresh water in the region). One of the characteristics of this area, utilized by the groups that live on it, is the half-round, concave shape of the land, that stretches east-west and is formed by hollows and elevations usually associated with Prehispanic structures (Barrera 2001:603, see Chapter 46 in this volume).

Vestiges of the Fort of Yo'okop (Fort no. 7) and the Fuerte de la Loma (Fort of the Hill), are located to the south of a modern road that runs northwest to southeast from Saban to Dzoyolá, at 9.5 km and 4.5 km respectively. Both constructions have been altered as a result of their abandonment, land use (currently dedicated to raising cattle), as well as the infrastructure necessary for a cattle ranch. Therefore, the former Fort of Yo'okop contains a corral composed of wooden posts and planks, which contains the livestock, and furthermore a large water trough that is connected by an improvised pipe to the old well, which has been adapted with a small container onto its southwest corner, where the water is deposited to flow directly to the trough. Likewise, another

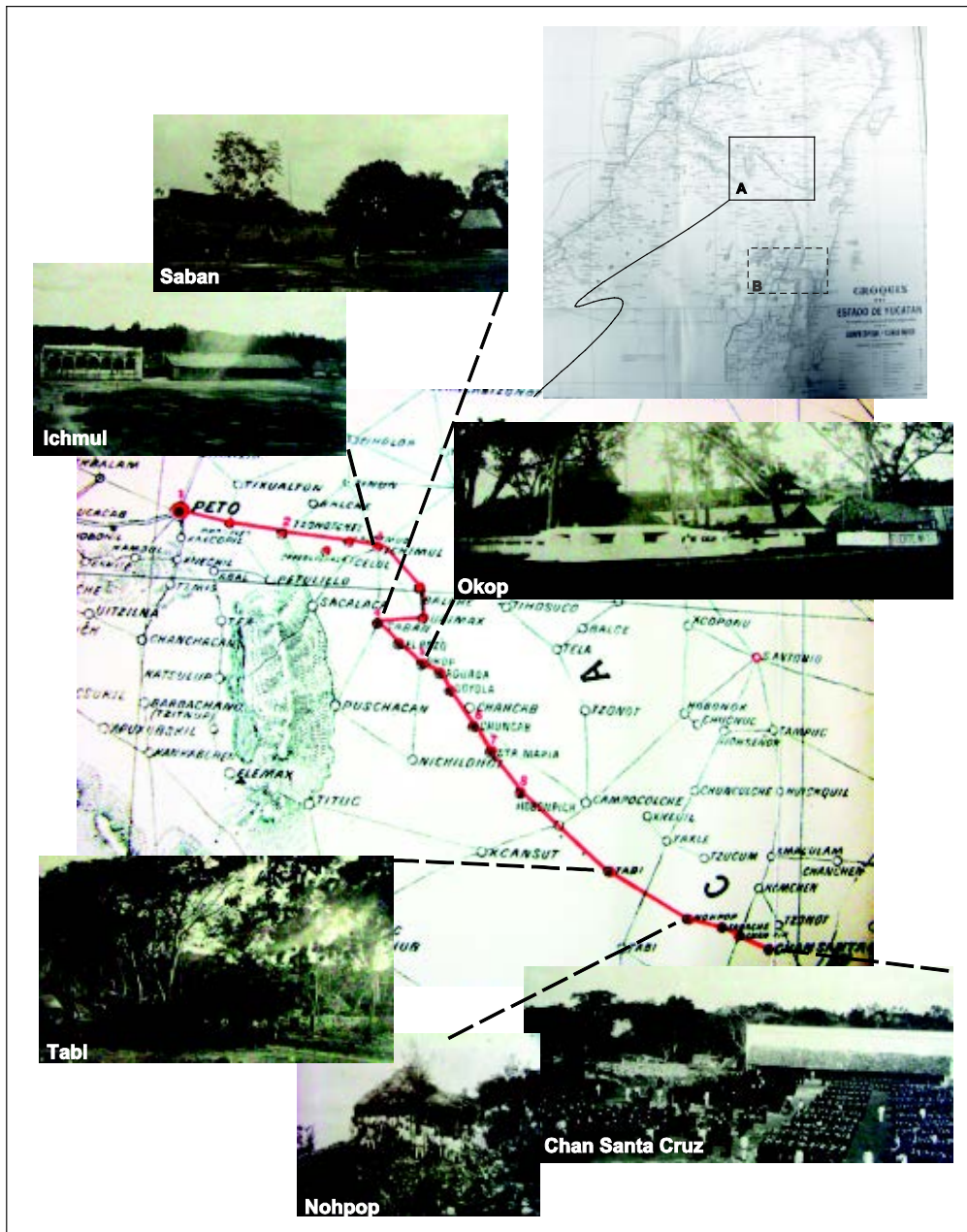

Figure 9. Sketch Map of Yucatán (Close up of the map entitled "Sketch of Yucatán, composed using data acquired by the special forces of the Estado Mayor" which shows the routes of the operations in the Campaign of Yucatán. A) Route and fortifications of General Ignacio A. Bravo. Their campaign covered the villages of (1) Peto, Progreso, (2) Tzontchel, Calotmul, (3) Ichmul, Balché, Uaimax (4) Saban, El pozo (5), Okop, La Aguada, Soyolá, (6) Chuncacab , (7) Santa María, (8) Hobonpich, Tabi, Nohop, Sabache, Chan Ik, until arrives to Chan Santa Cruz. B) Second Eastern Front towards Bacalar. Sketch of Bernardo Reyes 1902 Annex 29, Volume II, and photographs of the photographic Album of the Campaign of the General Bravo. Ca. 1901, Mérida, Cresencio Carrillo y Ancona Library.)

corral surrounds the same area of the old fort; its function is to keep the cattle from entering certain areas and to protect the main vestiges of the Caste War fortification. Additionally, another construction within the fort area was observed, a modern house of perishable materials used as a shelter by the owners of the cattle ranch.

Considering the activity to which the area has been subjected, one can assume that this nineteenth century construction displays an advanced degree of deterioration. The Mexican archaeologist Luis Alberto Martos, during 1998, conducted a series of explorations, excavations and surveys in the fort area. As a result of this, it is possible to know the appearance of these ruins twelve years ago. His report of 1998 describes in detail each space included in both forts, as well as several architectural elements in its interior (Martos 1998 and Martos and Rodriguez 1998).

With this brief review of the fort's history, and according to the goals of the CRAS Project, we will continue with the description of the process and the results of the topographical documentation of this site and its surrounding areas.

Mapping History: Prehispanic and Caste War structures

"On the other hand, the ruins still give signs of life"

TIME IN RUINS
Marc Augé 2003

Time is ephemeral, only constructions and the architecture persist despite the onslaught of the time. Through this, survives the history, temporary perspectives, and events that developed with the passing of time, into a space (northwest area of Yo'okop) where lie the remains of two distinctive places, not contemporary (one Prehispanic while other from the nineteenth century), each one expressing a different sense of the history.

The "Fort of Yoko'op" and "Fuerte de la Loma" (fort of the hill), as they are known today, are an example of warfare that occurred in the late nineteenth century, between the Maya and Mexican Military. These are odd structures in comparison to Prehispanic Yo'okop, and did not share any of the ideology of the ancient Maya city inhabited from the Middle Formative through the Postclassic period. The military forts were located in an area, approximately 2 km northwest of the ancient city of Yo'okop. With this newer constructions, the troops of General Ignacio A. Bravo adopted this space, creating a different sense for their own benefit, generating a new place. As Augé states " Toda construcción tiene una relación con la historia...que se desplaza en función de las evoluciones y las revoluciones" (Augé 2003: 122). In this case, the military architecture of that Military Campaign in Yucatán, constructed by the advanced guard that traversed from Peto to Chan Santa Cruz, resulted in several constructions, reconstructions and/ or destructions of structures of previous periods. For example, both forts at Yo'okop had been built after the destruction of an ancient structures in the surrounding areas, structures dating from Prehispanic times, which can be observed in: a) well cut stones that are part of several sections of the outer wall, as well as b) in mounds located under some bastions, furthermore by c) the existence of high concentrations of Prehispanic

ceramics on surface, in several d) masonry walls which are located under the surface level of the Fuerte de la Loma (and are partially exposed), and e) utilizing the terraces configured on the slope of the hill.

Therefore, it should be taken into account that the construction material used in the construction of both forts could be from an earlier period, and during the nineteenth century it was reused, becoming part of another culture, and subsequently producing a strange mixture that would have never may have been contemporary. The architecture of these military forts is a fusion of time periods, of materials from different cultures. When in that space, remnants of history can be observed, evidence of two places that exists in different times, one Maya and the other military, places which had different functions, different meanings to the social groups that inhabited these places. These are possible to physically delimit through topographical reconnaissance of the current site, where one may define the settlement pattern of the constructions, as well as the plans of different times.

In order to study the relation between Prehispanic structures and others that belongs to historical periods, a topographical survey was conducted using a Topcon GTS-213 total station and a data collector. The study area is located between 22 m N and 3 09 012 45 698 m E, and 22 m N and 3 08 981 45 681 m E, covering a region included within Saban *ejido*, within the *municipio* of José María Morelos, in the state of Quintana Roo. Access to this site is through the Saban-Dzoyolá road, 9 km to the southeast of the first town mentioned. Both forts are surrounded by a low forest; therefore it was necessary, prior to initiating the mapping, to clear some parts of the settlement. Some areas were well cleaned but others, due to time constrains, were only crossed by a longitudinal cleared segments (*brechas*) to minimize the efforts invested in this activity. Two days and eight workers were dedicated to the cleaning process.

The survey began with a reconnaissance of the area, and the location of the stations. Subsequently, mapping was initiated with the establishment of Station 1, pointing to magnetic north and with coordinates X, Y and Z at 0. The survey was conducted through equidistant transects of 5 to 10 m, advancing in a NW - SW direction towards the center of the fort. In the remaining area, a SE-NE direction was followed. Using this method, the hill fort was recorded, which also included the Prehispanic terraces and walls on which the military settlement was placed. It should be noted that due to dense vegetation, as well as time constraint reasons, it was not possible to establish a continuous network of stations to integrate both fortifications of the Caste War, with Prehispanic walls, and the surrounding landscape. However, in order to relate this social landscape formed during different periods on a single topographic map, both maps were joined through geographical coordinates of two starting stations (Station 1 and Station 8 respectively).

Due to the size of the area to be mapped and low visibility through the vegetation that remained after the clearing, a total of 8 stations were used in the fortification next to the road (Fort of Yo'okop) and 7 stations for the hill fort (Fortín de Yo'okop) and its surrounding zone.

The location of the stations allowed investigators to carry out the topographical map of the majority of the area with surface remains. Data processing of collected information generated, as a result, topographical plans that show the location of alignments, walls and Prehispanic mounds, all related with the Caste War military

constructions. These military constructions have been well represented in maps and described in detail in previous works, such as that conducted by the archaeologist Luis Alberto Martos in 1998, so in this paper only re-describes the general aspects of them. Topographic maps of these Caste War military constructions, resulting from this field season's work, may be complemented with those made in 1998, in order to determine the degree of conservation of this site twelve years later.

However, as the result of this current investigation, new topographical records and descriptions of the Prehispanic vestiges were provided. These ancient structures and features were used as raw materials for the construction of nineteenth-century Caste War fortifications (see the following topographic map of the Hill Fort and Fort of Yo'okop).

In an exercise of deconstruction, we begin with the description of aspects of the surface remains belonging to the nineteenth century military forts, which served as defensive points, control and advance guards during the Yucatan Military Campaign led by General Ignacio A. Bravo in the Caste War. It is necessary to say that due to concepts derived from military architecture, these will be referred hereafter as "Fort" and "Fortín" (fortalice) of Yo'okop, a distinction that will be explained below.

Today, a series of long "*albarradas*" (dry walls) that are the remains of the former, well-plastered fortification walls can be observed; some areas still are well preserved with rocks *in situ* (Figure 10). Contemporary access to this site is on the north side, where an old well is located. However, when the fort was in use during the nineteenth century, the formal access was through the west wing, since the well area one of the most protected due its vital importance for the maintenance of the troops (Figure 11).

The Fort of Yo'okop, architecturally, was a semi-permanent construction, since General Ignacio A. Bravo ordered its construction as part of what he thought would be a quick and systematic campaign against the Maya Cruzob (crusaders), which began in Peto (1899) and culminated with the capture of Chan Santa Cruz (1901) (Figure 12). A fort is a small fortification work, whether permanent or temporary, mainly the latter one; it is dedicated to defending a natural pass or constitutes part of a system (Ortiz 1993: 286). The Fort of Yo'okop has a polygonal shape with four bastions² each one in a corner; NW, SW, SE, and NE³. These formed a pentagonal plan flanked with curtain walls⁴ that united them. On its west side, which was formerly the front area, there is a rectangular area attached to the curtain or fronted wall that could have served as a lookout post⁵.

² Defensive structure of pentagonal convexed plan, consisting of two opposed faces in an angled ledge and converges into the interior, forming the flanks. The fifth side called gorge, is often open by a door, giving access to the interior. The importance of the bastion, as a defensive structure, not depends on its shape, but the geometrical combination that originates, that is called as bastioned front, which is a continuous polygon consisting of two media and adjacent bastions and a curtain or fronted wall that joins them (Ortiz, 1993:282).

³ Bastion NW and Western Bastion, in Martos and Rodriguez 1998: 13 and 17 respectively.

⁴ Long and straight section of the fronted wall between bastion and bastion. There is an extension wall that separates the most important structures, from which receives such protection and flanking (Ortiz, 1993:283).

⁵ Martos and Rodriguez (1998) interpreted this area as a midden with abundant material of glass bottles in surface, besides others buried in the ground. It is where a coin of the early twentieth century was found (Martos and Rodriguez, 1998:17).



Figure 10. Fort of Yo'okop, Vestiges of Fronted Wall of the NE Bastion



Figure 11. Fort of Yo'okop, Well and Foss (seen from north to west)

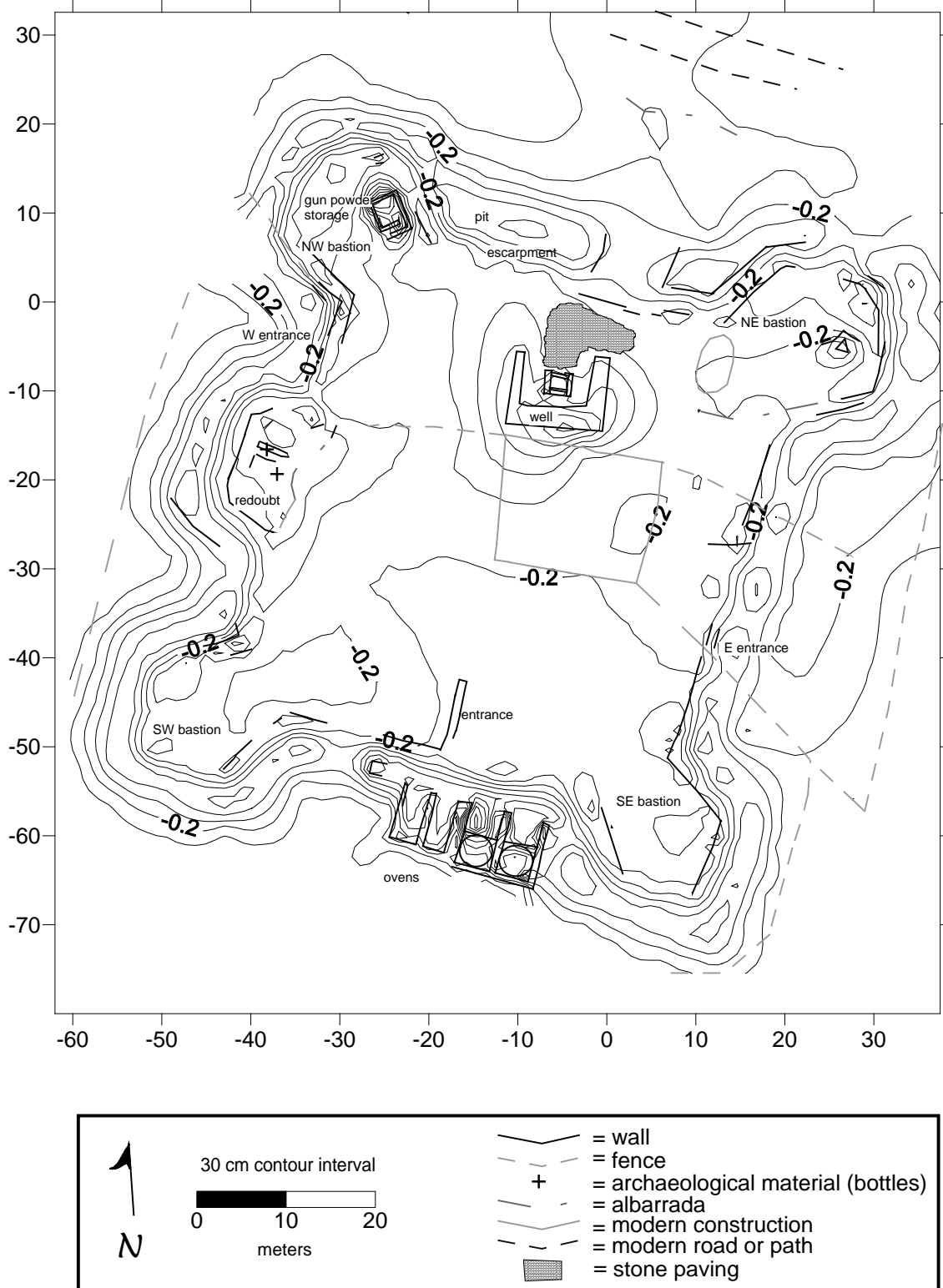

Figure 12. Topographic Map of Fort of Yo'okop

(military battery ⁶ or redoubt⁷), which controlled access. Within this area, a significant number of green bottles, in an upside-down position and half-buried, are located, on an east-west alignment; still others lie without any particular order towards the depression⁸ (Figure 13). On the east side is a direct access to the slope leading to the construction of the hill (Fortín de Yo'okop), as can be seen in the topographic map of Fort of Yo'okop (Figure 14).

Around three of the facades, a foss or ditch encircles the fort. It is 1.5m wide with a depth ranging between 1 and 2.5 m⁹ composed of a sloped¹⁰ bottom and escarpment¹¹. An old photograph shows that the battlements had walls¹² and gun emplacements¹³ and a possible parapet wall¹⁴. Today, as a result of Martos' and Rodriguez's excavations, conducted in 1998, it is possible to corroborate the existence of ramps to direct the guns of the gun emplacements, to defend the fort. In the northwest area of the foss, the remains of the battlements can be seen, collapsed from their original position but still plastered (Figure 15).

Within the fort, near the north façade, a water well is located, fitted with low walls and a beam to set a pulley in order to obtain the liquid, ensconced by the eastern, western and southern walls of the fort (Martos 1998: 4; Martos and Rodriguez 1998: 4). To the north of the well, the floor is paved with well-cut stones brought here from other areas (Figure 16). At the center of the fort are a series of stone alignments, some of which are directed towards the south side where, outside the fort, a series of rooms are located. Two of them are semi-circular structures, which Martos refers to as ovens for food or for smelting war implements (Figure 17) (Martos and Rodriguez 1998: 10,20-22). Finally, inside the NE and NW bastions, two underground rooms can be observed, which were possibly used to store artillery or gunpowder (Figure 18) (Martos and Rodríguez 1998:14).

6 Defensive fortification, specially designed to be protected by a considerable number of artillery pieces, collected and placed undercover (Ortiz, 1993:282).

7 A relatively small construction, closed by the gorge, whatever its form. Regarding its shape, this can be polygonal or well circular, the only condition imposed is that outside territory can be scouted appropriately, while leaving sectors without a fire position, where faces are located at the most convenient directions, in order to not be enfiladed. Usually, every redoubt has a side where it is more probable to receive an attack, which is called as "front head", while the two adjacent sides are called "sidelong" or "sides" and "gorge" to the opposite one (Ortiz, 1993:286).

8 Back has no parapet, imaginary line joining the ends of the sidewalls (Ortiz, 1993:285).

⁹ According to Martos, 1998:3 and Martos and Rodriguez, 1998:10.

¹⁰ Face of the foss corresponding to the face of the parapet or fortification wall (Ortiz, 1993:283).

¹¹ Talus or slope of the outer foss (Ortiz, 1993:283).

¹² Prism that rises above the parapet, at the top of towers or masonry walls, generally, equidistant from the body of one or two men, to shoot clear and covered by the wall (Ortiz, 1993:281).

¹³ Space between battlements to put cannons (Ortiz, 1993:283).

¹⁴ Road situated behind the parapet and on top of a fort, next to the battlements, where the defense is conducted (Ortiz, 1993:281).



Figure 13. Stone Alignment with Bottles, within Western Redoubt



Figure 14. Rear Access to the Fort (today located to the east)



Figure 15. Collapse of a Battlement Located into the North Area of the Foss (north of NE Bastion)



Figure 16. Stone Pavement North of the Well, Fort of Yo'okop



Figure 17. Rooms with Semi-circular Structures (ovens), South of the Fort of Yo'okop



Figure 18. Gunpowder Arsenal or Storage of War Implements

Vestiges of the fort show different areas of activity, which had specific uses. If the old photographs of the fort are observed in detail, it can be distinguished that in the internal area lay a number of perishable constructions. These delimited several areas within the fort, whose remains are a series of stone alignments, that Martos asserts "al interior del fuerte se detectaron una serie de alineamientos de piedra anclados al piso, los que corrían paralelamente a los muros periféricos del fuerte; aparentemente estos corresponden a un sistema de andadores o áreas de circulación interna, que permitan acceder a las diferentes construcciones de materiales perecederos que se levantaron dentro del fuerte" (Martos 2010: 122). One of these walkways is directed towards the south, which is "un pequeño pasillo perpendicular que conduce a la zona de hornos" (Figure 19) (Martos 2010: 122).

Is no wonder that even stables were constructed, as can be read in following chronicle about General Ignacio A. Bravo: "ha sabido arreglar y disponer las cosas de manera que las fuerzas federales de su mando disfruten de la mayores comodidades y del mejor trato posible, de una buena alimentación, sana y nutritiva, y de inmediatos cuidados médicos...entre la ración diaria por soldado estaba harina, azúcar, café, arroz, manteca, sal, frijol, carne fresca, alcohol...el General Bravo ha recibido varias partidas de ganado que forman un total de más de 300 piezas, que se guardan como reserva en potreros hechos al efecto, pues ha celebrado un contrato en virtud del cual le serán proporcionadas 125 cabezas cada mes, destinadas a la alimentación diaria de los soldados" (México Militar 1900th: 195). This is an evidence of the internal planning that may have existed inside the fort, including activity areas such as food warehouses, artillery and gunpowder storage, cattle raising, an infirmary, kitchens, etc.

The Fort of Yo'okop is not the only military construction in this area. To the south, upon an elevation that rises over 40 m, a construction known as the Fuerte de la Loma (Fort of the Hill) is situated. Due its dimensions and military architecture, we refer to this as a fortín (fortalice), a concept that refers to a small and isolated fort, unlike the other fortification previously described (Fuerte de Yo'okop).

The Fortín of Yo'okop of is a fortified complex of smaller dimensions, when compared to the Fort of Yo'okop (Martos 1998: Martos and Rodriguez 1998: 8). This fortalice is a construction of an irregular polygonal shape, elongated in its northwest-southeast axis, and crowned with two bastions, one to the NW and the other to the SE (Figure 20). Both bastions display irregular plans, flanked by features that connect them; access is located on the north side, as can be observed in the topographic map (Figure 22). The front walls are a meter wide, and are still preserved to a little more than one meter in height. At present, they appear to be simple *albarradas* (dry walls) since the stones are positioned without any mortar that may have served as a agglutinant (Figure 21). The natural terrain where this fortalice was positioned is highly rugged, thus this prevented a regular layout. This fortín was a defensive complement of the military system. Different areas are observed in which diverse activities were organized, but it is not possible to define which area corresponds with a specific activity without conducting excavations (Figure 22).



Figure 19. North-South Stone Alignment, Near the Oven Area, South of the Fort



Figure 20. SE Bastion, Seen from North to South
(note the different level of its construction)



Figure 21. Western and Eastern Features that Link the SE Bastion with the NW Bastion, and the other areas of the Fortín (fortalice), respectively

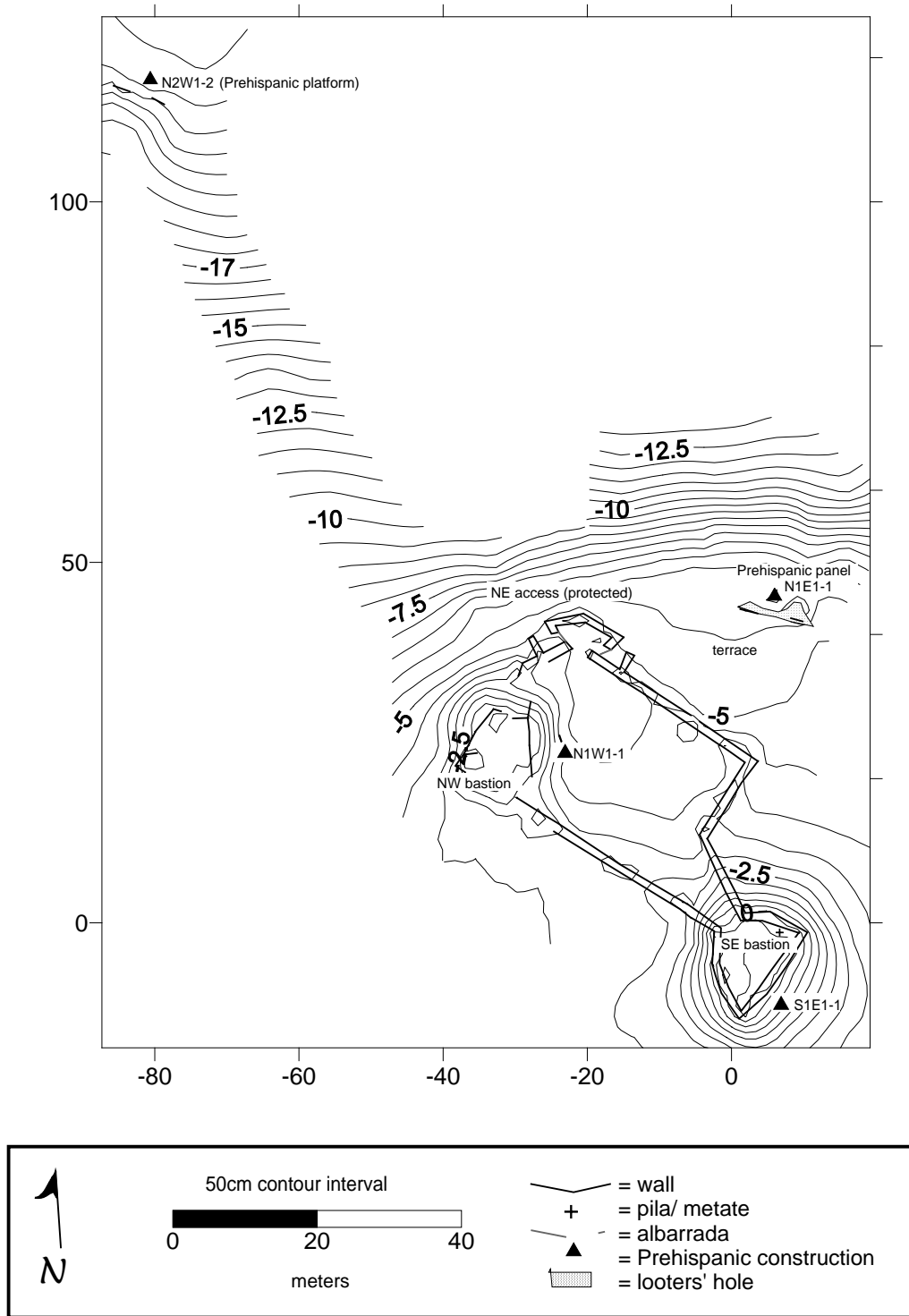

Figure 22. Topographic map of Fortín of Yo'okop (fortalice)

In general, the location of military constructions, as forts and fortalices, is directly related with the type of terrain on which they are situated, the kinds of raw materials necessary for their construction and the type of conflict or the amount of time available to organize the defense. Nevertheless, each has areas of activities that are organized differently, in order to be functional for those who inhabit them and effective for their strategies. In addition to this, each contained roads, gun yards, areas dedicated to communication, areas for artillery and infantry, gunpowder storage, food storage, sleeping rooms, and water tanks, among other things.

Due the lack of specific historical documents, it would be necessary to conduct several excavations to reconstruct part of the history of the activities carried out in the Fort and Fortalice of Yo'okop.

Both constructions were connected with other fortifications through a 16-km road constructed by General Bravo, which began in the town of Peto and ended in Chan Santa Cruz. Apparently this road followed a preexisted route that probably existed since Prehispanic times. It continued to be used and known to traders and *campesinos* (farmers) during Colonial period, being enlarged by Bravo during his campaign early in the nineteenth century (Martos 2010: 119,120).

Regarding the raw materials employed in the construction of both fortifications of Yo'okop, it seems pretty obvious that a large number of stones of Prehispanic structures were re-utilized. Martos and Rodriguez (1998) claim that material in these military constructions, mainly well cutting stones, comes from archaeological structures. Therefore is highly possible that "no muy lejos del sitio se localice un grupo estructuras arqueológicas." Also these investigators emphasize the irregularity of the surface of the hill where the fort is located, suggesting a highly modified environment, which determinated the shape of the fortalice. New findings from this season confirm such a hypothesis, as will be discussed (Figure 23).

Group A of the Prehispanic site of Yo'okop lies next to La Aguada, which is the largest body of water in the region; it is about 2 km southeast of the nineteenth century fortifications. Yo'okop is an ancient major Maya city with structures and palaces of significant sizes designed for specific functions, *sacbeob* (causeways) that connected the area the architectural complexes. Due its importance, this city may have dominated this region, many structures of minor dimensions and several architectural complexes are distributed in a broad radius around the site (Shaw and Johnstone 2000 and 2002). It can be considered to have had a radius of Prehispanic remains for at least 2.5 km from Group A, as has been demonstrated by a survey conducted this season (see Chapter 46 this volume). In the area surrounding the Caste War fortifications, at least 20 structures, in addition to several *albarradas* (dry walls) and terraces, were located.

These findings suggest a Prehispanic occupation in the area to the northeast of Yo'okop. According with our topographical maps, the irregular space on which the fortalice is constructed results from its construction over a previous Prehispanic settlement. Structures S1E1-1 and N1W1-1 were partially dismantled to construct the military fortification, using the ancient social landscape to position its bastions on the highest point (Figure 24).



Figure 23. Difference in the Ground Level between the SE Bastion and Western Side of the Fortalice of Yo'okop



Figure 24. Prehispanic Wall (possible structure), Located below the SE Bastion of the Fortalice of Yo'okop

The highest part of this northwest region of Yo'okop, where the fortalice is located, shows the remains of structures do not correspond with the military architecture of either Caste War fortifications; rock alignments and architecture point to a different angle, as seen in a partially buried wall of well-cut stone that has been found within a looters' hole, a few meters below the NE curtain of this Fortalice of the Hill. It is below the level of the military construction, Structure N1E1-1 on the topographic map (Figure 24). A partially exposed wall is visible, whose façade resembles an Early Puuc style, without mortar between junctures and devoid of any ornamentation, with at least ten courses in its south extreme, and three courses in the northern one. This wall has a northwest-southeast alignment (Figure 25). The construction technique of the architectural element coincides with what Pollock called "mosaics," and G. Andrews believes that it reflects an advanced degree of specialization in the cutting and alignment of stones, because it has been conceived of as a smooth façade surface (cited in Gendrop 1983:145). Although it was not possible without excavation to observe the total length of this element, it is supposed that it belongs to the façade of an Early Puuc structure, although Gendrop states that this kind of element also can be found in the Late Puuc style. This hypothesis could be corroborated or refuted through excavations.

Furthermore, the slope to the east of the fortalice is modified by a series of terraces several meters wide that descend from east to north. They are irregular and, on occasion well-defined as steps, forming a sort of terracing to the bottom where stone blocks, rectangular and well-cut lies arranged horizontally in an east-west direction, as can be noted in the map in Structure N2W1-1 (Figure 26).

Prehispanic constructions in this space show a different configuration from the nineteenth century fortifications. They represent two places that correspond to unique and incomparable cultures and ideologies that shared, in different times, the same space. Today, both arrangements - Prehispanic and military - are the subject of new, modern activity, cattle raising, and are impacted by all of the infrastructure necessary to conduct this work. Several modern features, such as roads, corrals, a water trough, and a hydraulic system to supply the livestock, were included as part of the topographical map in order to enable the planning of a conservation strategy for this significant historical site.



Figure 25. Puuc-style Architectural Feature



Figure 26. Cut Stones Located South of the Fort of Yo'okop

About Space and Place: Social landscape dynamics over time into the northwestern region of Yo'okop

"The ruin is a fact, is the time that escapes to the history: a landscape, a mixture of nature and culture that gets lost in the past and arises in present as a sign without meaning, no other meaning, at least the feeling of time passing and, at the same time, persists "

TIME IN RUINS
Marc Augé 2003

Landscapes that seem to be natural owe, all of them, to the hand of man, are completely separate from nature (Augé 2003:85). For this paper, landscape is conceived as a social construction, a collective transformation of nature and a cultural projection of a society in a given space. It is where *space* is the raw material on which a landscape is constructed, and its meaning, the creation of a *place*.

Landscapes are full of places that embody the experience and aspirations of human beings. They are constructed and respond to an ideology that seeks to transmit a particular form of appropriation of that space (Nogué 2007:11). At present, landscapes appear as a curious mixture of nature and culture in the same space that melt over time with other landscapes. Following Nogué (2007: 15), many landscapes survived over time and, despite lack of context or identity, are still there without being there; they are not what they were but still are in the present.

Spaces are transformed and redefined according, and in relation, to the social dynamics of humans who create and recreate the existence of landscapes, through patterns of meanings that permit them to exercise control over their behavior, because people assume these manufactured landscapes have a natural and logical means. The architecture of these constructed landscapes is a social projection that generates an iconical code, denoting functions and meanings that are subject to loss, recovery, and replacement in the course of history. This promotes a certain means of behaving by allowing its use; it is the significant links that predispose their functional use (Eco 2007: 283).

Between the Maya and the military there elapsed a social dynamic in the northwestern region of Yo'okop, in which the space of the two cultures was melded, two identities in two different periods, creating two sites with opposite characteristics and antagonistic functions. The space had been selected in either time, due to its geography, to provide a visibility and strategic view, a limited route of access across a rugged terrain and to ensure access to natural resources, such as the well, which has the most direct access to water table in whole region, at only 7 m deep.

Constructions situated atop the high ground northwest Yo'okop, such as the nineteenth century fortalice known as Fortín de Yo'okop or Fuerte de la Loma, as well as Prehispanic structures, adopted a space and transformed it into a lookout position in order to control the area, due its privileged location across a natural hill that, somehow, facilitated visual communication with the rest of the region. This hill and terrain to the

northeast flanks a lower area that seems to be a long glen, a natural pass to the core of Yo'okop from the northwestern and the southeastern portion of the region.

Prehispanic inhabitants selected this space atop of area and its surroundings to construct structures, ranging from small platforms to mounds of 3 m height, taking advantage of the proximity of access to fresh water in the lowest area, in addition to the high visibility from the top of the hill. From that position, the space offers an excellent¹⁵ and very extended visualization, since that the relief of Yo'okop's region descends towards the east until the periphery of La Aguada; thus, from this point, the whole region of Yo'okop can be observed quite well. In addition, based on the data obtained this season, we speculate about the possibility that visual communication from the point in the modern fortalice of Yo'okop with the tallest buildings in the main groups was established. At present, this is not feasible due to thick secondary vegetation. If this was possible in the past, with no forest in between, then the position were the fortalice is situated would have been an excellent point of control and/ or access to the territory dominated by this First Order settlement.

Gradually, social dynamics of the region were changing; some landscapes were transformed and others remained physically, but were submitted to the loss or replacement of their meanings. Time passed...in the territory of modern Mexico, large cities declined and the growth of new centers of power occurred during Prehispanic times until the arrival of the Spanish in the sixteenth century. Various campaigns of conquests for these new territories were conducted between the sixteenth and seventeenth centuries, resulting in the social, political and religious transformation of the region, and the establishment of a colony that configured the spaces for the convenience of the Spanish kingdom. Social conflicts, breaking out in the colonial governmental politics, social movements such as the independence of New Spain, the abrupt development of a "new" nation (México), stabilization and new conflicts, as well as armed insurrections during all Nineteenth Century...all were transformations where urban and rural landscapes were configured as time continued to pass and new ideologies were created.

In the northwestern region of Yo'okop, where the vestiges of these fortifications and Prehispanic structures cohabitate in the nineteenth century, a group of military members of the Campaign of Yucatan, conducted by General Ignacio A. Bravo against groups of *campesinos* Maya rebels, having departed of Peto and after building several fortifications in Dzonotchel, Ichmul and Saban, arrived at this space of a unremembered place. Due to its strategic position, they decided to construct, according to their military purposes, a new place in that space, probably guided by old chronicles of Maya hunters or by those ruins of other times, whose original meaning have been hidden by a thick tropical forest that slowly took possession of them (Figure 8). The selected space is where a modern well is located; in their environs, soldiers built a fort employing stones from Prehispanic constructions located in the outskirts of Yo'okop.

The well was an important element in the selection of this space and the construction of the fort. Some manuals on military construction mention that the water

¹⁵ Estimate of the perception of this built spaces. Visualization can be understanding as how a given archaeological complex or element is observed from it and over the environment, while visibility is what can be seen from the archaeological site to other places or the outside (Mañana, Blanco and Ayán 2002:38)

supply is a crucial issue to establishing a fortification, since it was not possible to admit that the garrison was obligated to procure water outside, when it was so indispensable for their support. In fact, when no water access was available, whether groundwater or superficial, or the drilling of wells was impossible, it was essential to construct cisterns that capture the water that falls on the entire surface of the fort. For this purpose, covered vaults would be arranged to form a series of slopes on which the rain water could drain to the cisterns (Legrand-Girard 1911:159).

In the case of the fortalice, the selection of this space was due its position on one of the sides of an extensive plain, a strategic position in that bellicose context of the Caste War. It was a space that had been occupied by an architectural complex in Prehispanic times, probably with the same strategic function. The nineteenth century military took possession of this space. For them, the old buildings did not generate any kind of meaning since it belonged to a constructed landscape out of its temporal context. To build a new landscape in the nineteenth century, those ancient structures were partially dismantled, adapting its relief to serve both as foundation as well as raw material. In an exercise of destruction and construction, a new military landscape was created, with a social context and meaning strange to the old structures. The military subsequently took possession of this space as a place where, utilizing military architecture, they determined their stay.

The case of the northwestern region of Yo'okop, where the Fort and the Fortalice are located, is a clear demonstration of the reuse of spaces and natural resources, where Maya groups chose their settlement and, some time afterwards, these spaces were taken to create, upon them, new forms, creating different places, and new meanings, spaces in which past landscapes remained, despite the impacts of time and the social context, merged to build new landscapes metamorphosed with new identities and new codes of history. A landscape is always strongly imbued with cultural connotations that can be interpreted as a dynamic symbolic code that talks about the culture of the past, and invariably, will be attached to the culture that produced it (Nogué 2007:21).

The irony of history is to provide a mixture of landscapes, places that once reflected opposite meanings, coexisting in the same space, as remnants of Prehispanic times or those of Colonial times or, in our case, with vestiges of this bellicose history of early nineteenth century.

*"The ruins [...] have the form of a memory,
are no memories of anyone, but are offer to whom goes through like a past that had
been lost sight of, that would have been forgotten, and yet be able to say something.
A past to which the observer survives"*

Acknowledgments

We will like to thank the workers of Saban *ejido* for their friendliness, fulfillment and support for conduct the topographical register of this site, also to Dr. Luis Alberto Martos, at that time, director of the Dirección de Estudios Arqueológicos of INAH México, for its accessibility, as well as references suggestions about Caste War, and

especially for the information provided about his research at the Fort of Yo'okop. Furthermore we express our thanks to Don Pepe, file manager of the Archivo Técnico at Instituto Nacional de Antropología e Historia in México City. In addition, we are infinitely thankful to the members of Secretaría de la Defensa Nacional, especially to General de Brigada Diplomado de Estado Mayor Miguel Angel Patiño Canchola, Director General del Archivo e Historia, to the Capitán Segundo Sergio and Historian Sergio Martínez Torres, and to the Subteniente Historiador María Luisa Alavés Castaño, members of the Historical Section of Archivo Histórico de la SEDENA, as well as with the staff of the library of the SEDENA. Thank you all for your kindness, your good advice and the hospitality they gave me to access to this vast collection of military history of the country.

Overall thank you all this persons, without their support this research would not be possible.

Part 2: The *Ejido* of Saban

Chapter 6: Gruta de Alux, Operations 1 and 2

Alberto G. Flores Colin

The settlement of Gruta de Alux is located in the northeastern part of the Saban *ejido* land. The site was visited and topographically recorded by Normark and Johnstone in 2008 (Normark 2008: 48-51). In that year, these investigators located a good number of structures, although the map only covered a small section, as the site is very extensive. The section that was registered had a pair of parallel structures (Structures S2W1-1 and S2W1-2), a dozen of circular foundation braces and an entrance to what seems to be a large cave (Figure 27). According to local consultants, the cave use to be a grotto, but the access to the greater chamber has been blocked by the collapse of several rocks (Flores, field notes 2010). Normark and Johnstone proposes, based on what they observe on surface, that this site could have at least two time periods (*idem*), speculating the possibility of circular foundations belongs to Postclassic, while parallel structures, perhaps a ball court, would be of earlier times. Based on this assumptions and as part of the basic site documentation process, it was decided to perform a series of operations (test pits) to obtain a better understanding of this particular settlement.

Operation 1 was a 2 x 2 m test pit , located in a sort of patio or courtyard conformed by Structures N1E1-1, N1E1-2, N1W1-2, N1W1-3 and N1W1-4, which lies on top of a natural outcrop of bedrock with little-to-no sediment. The depth of this unit was not much and consisted only of one level. Level 1, Lot 1 consisted of a blackish soil layer (7.5 YR 3 / 2) mixed with several stones of different sizes, from large (about 40 x 40 cm) to the gravel or *chich* in Maya Yucatec (about 5 x 6 cm on average). These stones were lying at different levels and did not appear to be a homogeneous layer, although they were scattered throughout the unit. In this level, in the south part of the unit a section of bedrock or *laja* was discovered. Ceramics found in this level permit us to assign it to the Terminal Classic period, evidenced by sherds of Yokat Striated and Muna Slate type. The end of this stratum occurred when the bedrock was located throughout the unit (Figure 28). After the completion of all task of recording, the excavation was completed.

Operation 2 was placed southwest of Operation 1, between the Structures S1W1-4 and S1W1-5, a circular foundation brace, which also lie on a limestone outcrop that formed a small hill. As well as Operation 1, the depth of Operation 2 was little, due to lack of sediment that exists over the outcrops (Figure 28b). Level 1, Lot 1 consisted of a blackish soil layer (7.5 YR 3 / 2) mixed with several stones of different sizes, without a homogeneous distribution. In the south of the unit bedrock was located close to the surface, while in the north are, an important number of middle size stones

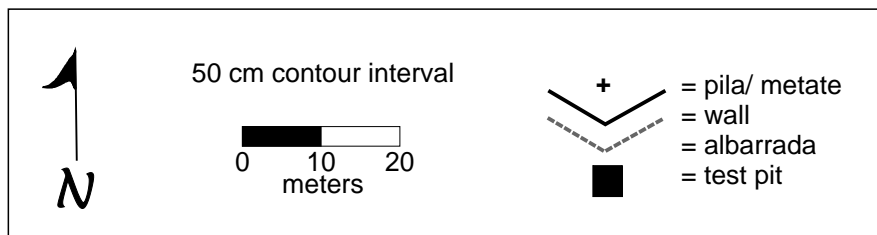
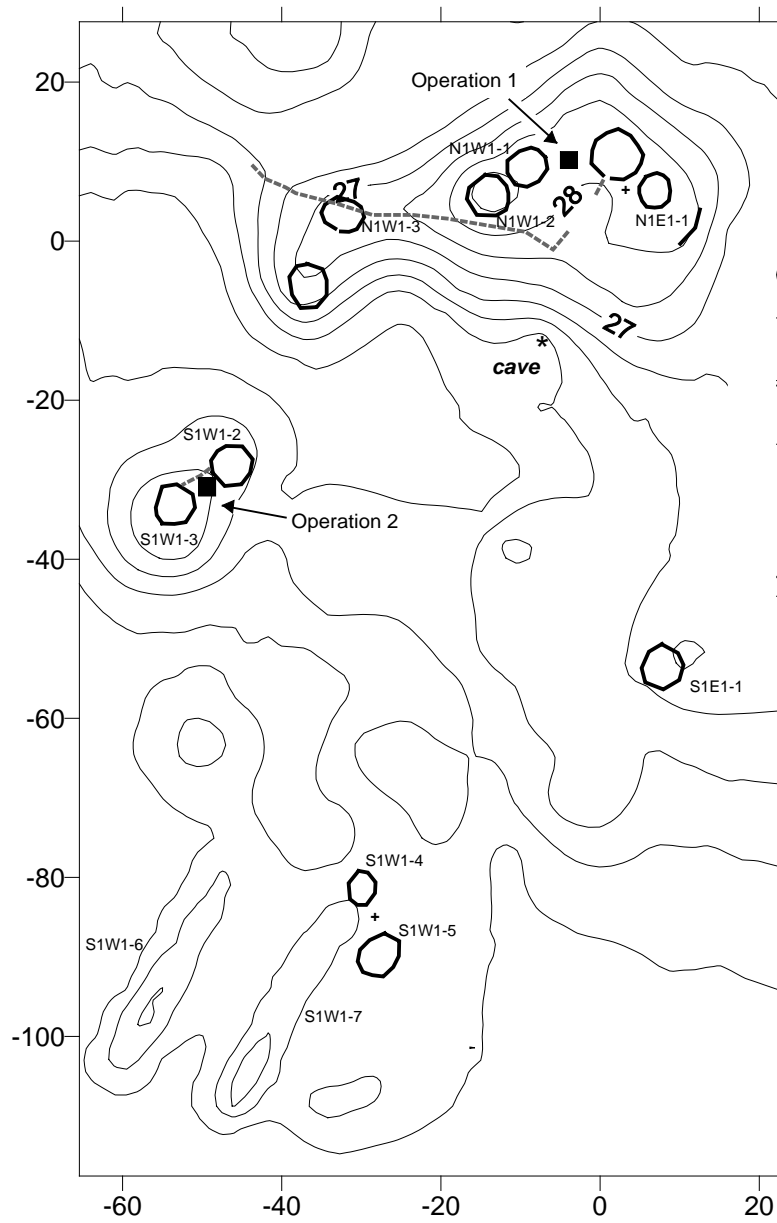

Figure 27. Gruta de Alux, Excavation Locations

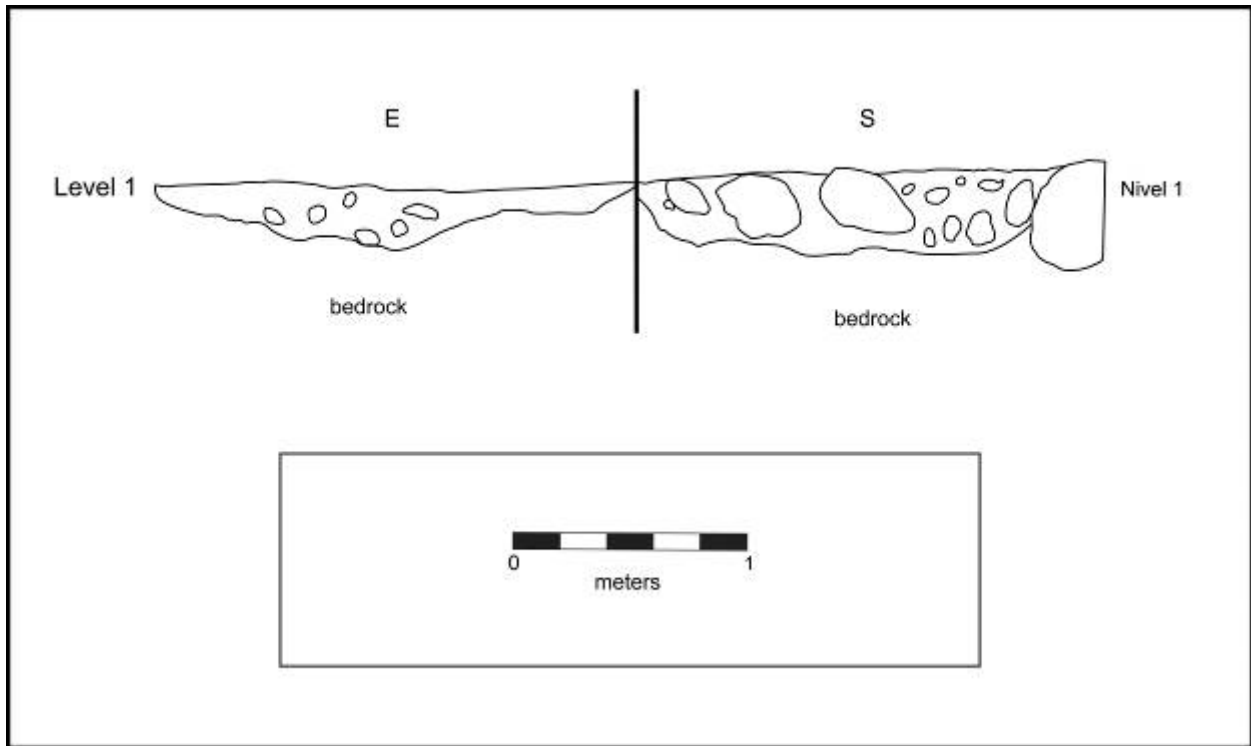

Figure 28a. Gruta de Alux, Operation 1, East and South Profiles

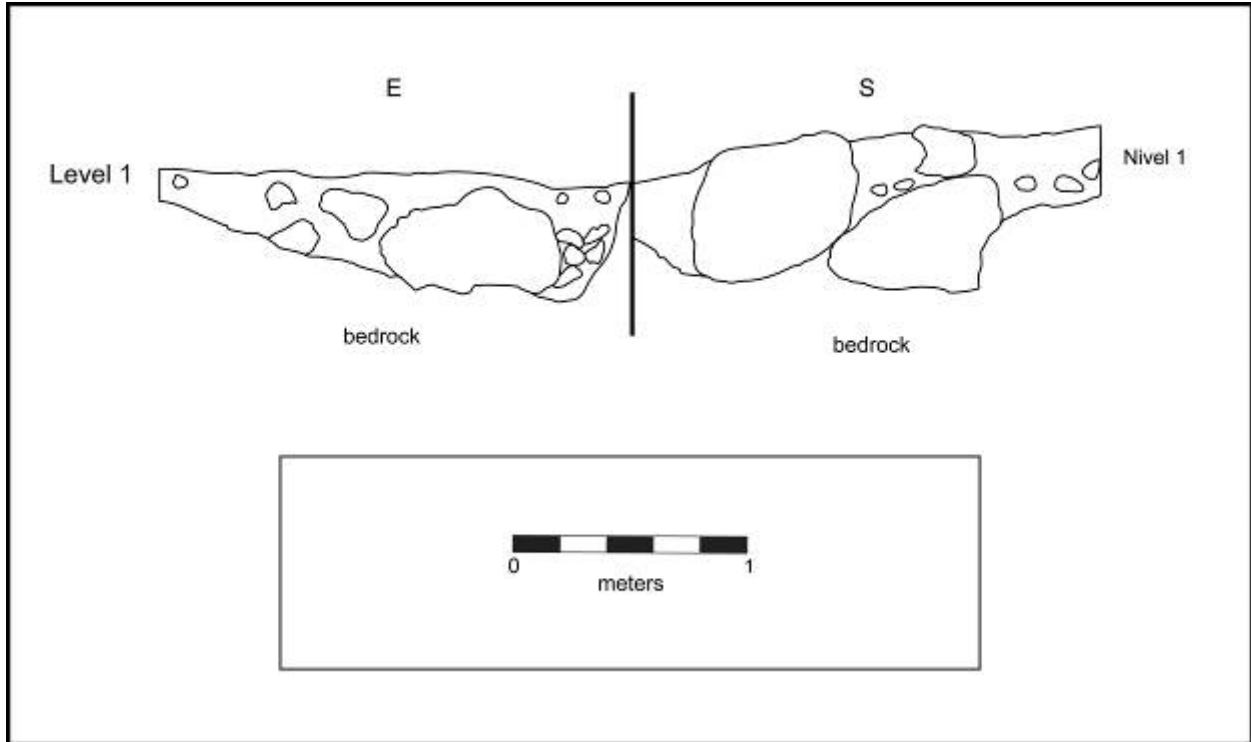

Figure 28b. Gruta de Alux, Operation 2, East and South Profiles

was found, but had no definite shape although it was a concentration, possibly part of a sub-floor of a surface or part of the courtyard pavement. Ceramic sample of this level was limited, in general throughout the unit, but were able to locate three sherds of Navula Unslipped from the Postclassic. Due to the emergence of a soil color slightly redder (7.5 YR 3 / 3) it was decided to change to Level 2, Lote 1, which ended with the discovery of bedrock throughout the excavation area. The concentration of middle size rocks, north of the unit, also was removed. During this process it was confirmed that these rocks lack of any apparent order or arrangement, which makes us speculate about that its deposition was natural. A single sherd was collected of this level, but could not be identified. Once all sediment was removed, and after leaving exposed the bedrock in hole unit, and following the registration of data through photographs and drawings (Figure 28b), the unit was backfilled to its original level.

Interpretation

Due to the shallowness of the soil and the position of the excavation units on the hills where lay the foundations braces, information obtained these excavations is scarce and inconclusive. The land where the site lies, have been subjected to traditional agriculture, which uses the slash-and-burn technique, as it much of the sherds that we obtained could not be fully identified. The low accumulation of sediment, also has favored that has any architectural feature such as a pavement or stucco floor had been survived to the present. Despite these factors, it may also raise some interpretations based on the characteristics that did not get. Although some sherds of earlier periods were found (such as Late Formative samples), no evidence of a long occupational sequence is present in this area of the site, as would be a paved surface or artificial leveling that will indicate the construction of this part of the site involved a more constructive effort, but rather, and based on what is observed on surface, it appears that these contexts are residential or domestic, and are settled directly on the natural ground surface. Unlike others test pits excavated in more formal plazas, there is no evidence of stucco floors or some kind of leveling surface and ceramics seem to be mainly utilitarian. The assumption about the circular foundation braces are evidence of perishable structures, furthermore they share practically the same dimensions of the contemporary traditional Maya houses, reinforce the hypothesis that we are excavating into a domestic context. However, the presence of the cave and two parallel structures (or possible ball court) do not fit with this assumption. Although it is necessary to perform other test pits in these areas (in the ball court and near or inside the cave), evidence observed in surface not indicates that a considerable constructive work had been conducted in this site, but it appears that future excavations will be similar to Operations 1 and 2, with a shallow depth due the low sediment and the existence of bedrock near the surface, thereby, to obtain better information on the site, will be crucial to conduct an extensive excavation. As previously Normark and Johnstone proposed (*idem*), it is likely that these parallel structures belonging to another period, however, although we found some Postclassic ceramic sherds in one of the units (Operation 2), the sample is very small and would be ventured to date these round foundations braces for this later period (only three sherds were found) despite architecturally they seem to be postclassical. Also it is possible that the circular foundation, at least those that are placed adjacent to the excavation units (Structures

N1W1-2, N1W1-3, N1W1-4, N1E1-1, N1E1-2, S1W1-4 and S1W1-5), are contemporary to the parallel structures (Structures S2W1-1 and S2W1-2). If parallel structures or ball court and the circular foundations braces, next to the Operations 1 and 2, are of different periods, these parallel structures will be in a disturbing isolation, due there are no other structures or mounds of monumental dimensions in the vicinity (the closest would be some small mounds about 100 m, not yet mapped). Ball courts are often found in sites with monumental architecture. In this case the apparent isolation would have to be explained. If the circular foundation braces (even if not all) and parallel structures or ball court are contemporary, we should investigate and interpret what constitute this complex context, perhaps one of ritual or symbolic nature. Another point to investigate is also the relative isolation of this site, since no other nearby settlement is known in a considerable stretch (see Figure 2). This due to that still we don't have located yet another site, or the influence of some greater settlement. Yo'okop is about 9.5 km to the southeast; relatively far away. However, according to local consultants, there is a site called Calotmul fairly monumental architecture, about 4 km to the east and lies in the *ejido* land territory of Tihosuco (*ejido* so far outside of our study area). It is also likely to exist near sites that have some connection with this settlement of Cueva de Alux; surveys in the eastern part of the Saban *ejido* land will continue next season. Although these units have left more questions than answers, the investigation of 2010 gives us the first clues to better understanding about the occupational history and the processes that occurred in this unique place.

Part 2: The *Ejido* of Saban

Chapter 7: The Site of El Palomar

Dave Johnstone

El Palomar is located 18 km southeast of Saban. Portions of the site are currently being farmed, additionally; the site serves as the location for several bee colonies. The historic portion of the site has been described by Kaeding (2008a), while the prehistoric portions were documented by Huerta (2008). The goal this season was to integrate these two maps, and to achieve a fuller understanding of the site's layout and history.

Like Pancho Villa, this site has been identified as a *hacienda* (Kaeding 2008a) on the basis of the presence of a masonry structure. This structure is unlike most of the historic masonry structures documented in the CRAS region, in that it is apsidal in shape- a feature shared with the house at San Pedro (Kaeding 2008c). The El Palomar house has a hexagonal shaped addition on its north side; likely post-Caste War. As the *albarradas* (dry laid field walls) were built onto the addition, it is likely that they are not contemporaneous with the original structure. According to local informants, the site was occupied until approximately 30 years ago. The remains of two perishable structures are located to the east of the masonry structure. A small rectangular enclosure located southeast of the main structure has been identified as a pig pen, as it lacks any formal entrance.

The Precolumbian portion of the site is rather extensive, though its limits have yet to be determined. The largest feature (Structure N1E1-1) is a 1-m-tall platform measuring 60x55 m. Two 1.5 m tall mounds are located on the east and west side of the platform (Figure 29). These have been heavily robbed for stone though it is uncertain if this was to build the *hacienda* or the *albarradas*. A rectangular foundation brace lies on the southern margin of the platform. Several Postclassic features including mini shrines, masonry alters, and a round foundation brace were built on top of earlier architecture.

East of the larger platform is a small rectangular platform (Structure N1E1-9) with a Postclassic mini shrine on its summit. This shrine is built with reused Terminal Classic veneer stones, and does not align with the supporting platform. A large section of the platform directly in front of the shrine is missing, and was likely removed in antiquity to permit easier access to the shrine.

The eastern portion of the mapped area of Palomar is taken up with three large residential platforms. These all were edged with megalithic blocks which we tentatively assign to the Late Formative to Early Classic transition. Only one (Structure S1E1-1) supports a superstructure; in this case a rectangular foundation brace.

A small surface collection from the summit of Structure S1E1-1 recovered ceramic remains dating to the Late Formative, Terminal Classic, and Postclassic periods. These data are consistent with the architectural chronology and suggest a minimum of three occupations for El Palomar during the Prehispanic period.

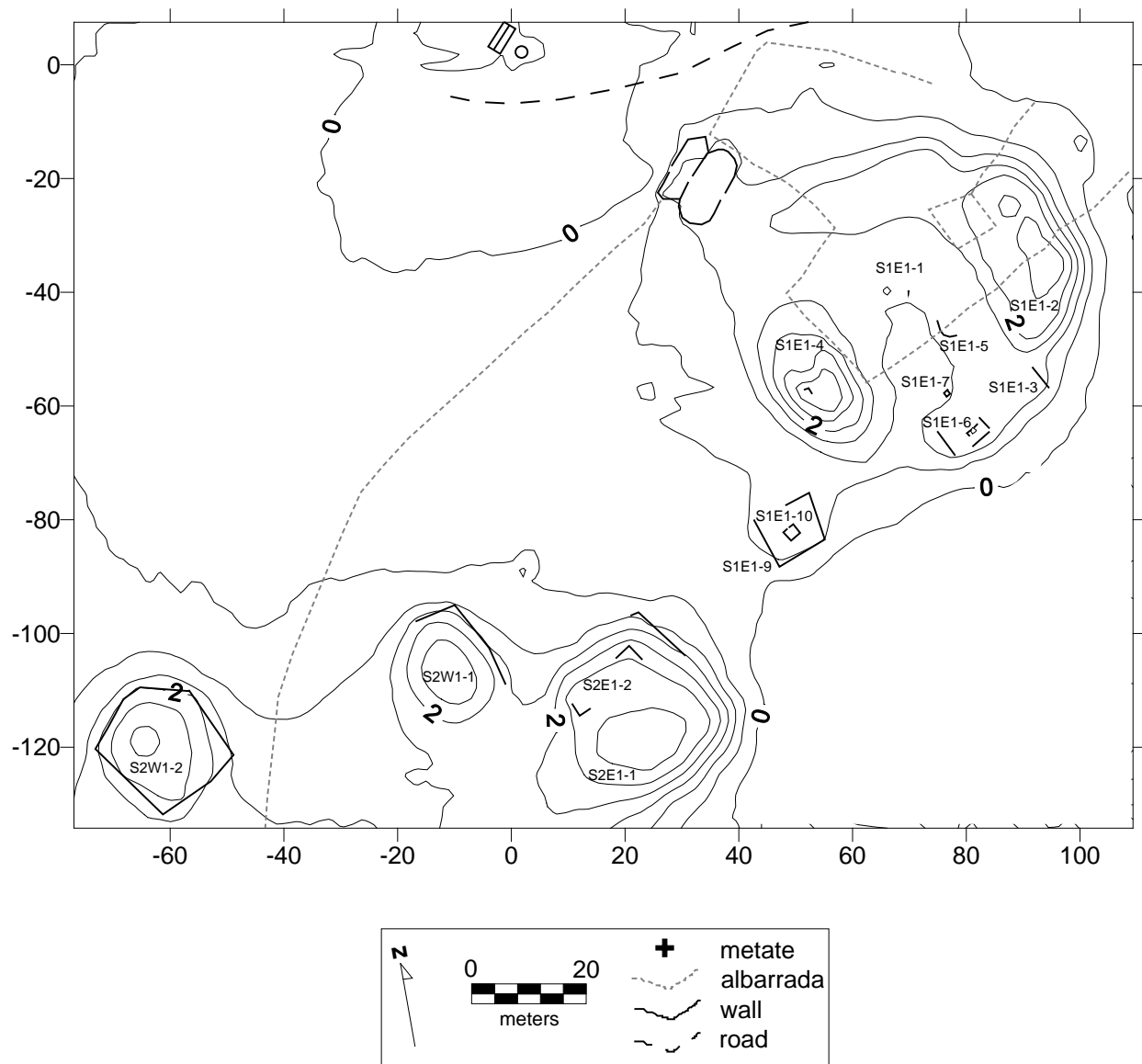

Figure 29. The Site of El Palomar

Part 2: The *Ejido* of Saban

Chapter 8: The Site of Pancho Villa

Dave Johnstone

Pancho Villa is located 6.5 km southwest of Saban. Presently, it is being used as an apiary, with occasional grazing of cattle. It was first recorded by Kaeding (2008b) as a *hacienda*; principally on the basis of the presence of a masonry structure. It is also notable for having a large formal masonry gate, and a raised *noria* (a well designed for operating with draft animals). Our map (Figure 30) was confined to the central portion of the site, and focused on the residential portion of the site. These structures were situated on a natural rise, giving the house a commanding view of the fields to the south as well as the north. On the western masonry column of the well is an inscription which reads “Sant Esperanza 1 de Marzo 1838”. As the name Pancho Villa probably refers to the Revolutionary war general, Sant(a) Esperanza was likely the original name for this *hacienda* that predates the Caste War. The only new feature documented was the remains of the *bebedero* (water trough) to the north of the *noria*. This trough was built of sawn limestone slabs with a single beveled top edge. Many of these slabs were widely scattered, with one being located some 30 meters south of the *noria*.

Pancho Villa displays some uncommon features seldom seen at typical ranchos. Masonry gates similar to that seen at Pacho Villa have been reported from the sites of Xbalcheil, Xbaquil, and Ramonal Poniente (Flores 2004). Raised *norias* are relatively rare in the Coahuah region, but have been recorded at the sites of Ramonal Poniente (Flores 2004), and San Pedro (Kaeding 2008c). Absent from Pancho Villa is a corral. This suggests that Pancho Villa was not focused on cattle, but on crops- probably sugar cane (Flores 2004:197). Though no Prehispanic features were noted within the mapped area, many of the stones used to construct the *noria* appear to have pre-Hispanic origins; suggesting that we might expect such features in the near vicinity. The site of Venadito is only 1 km distant, and is linked by a trail. It is possible that the reused stones originated at that site.

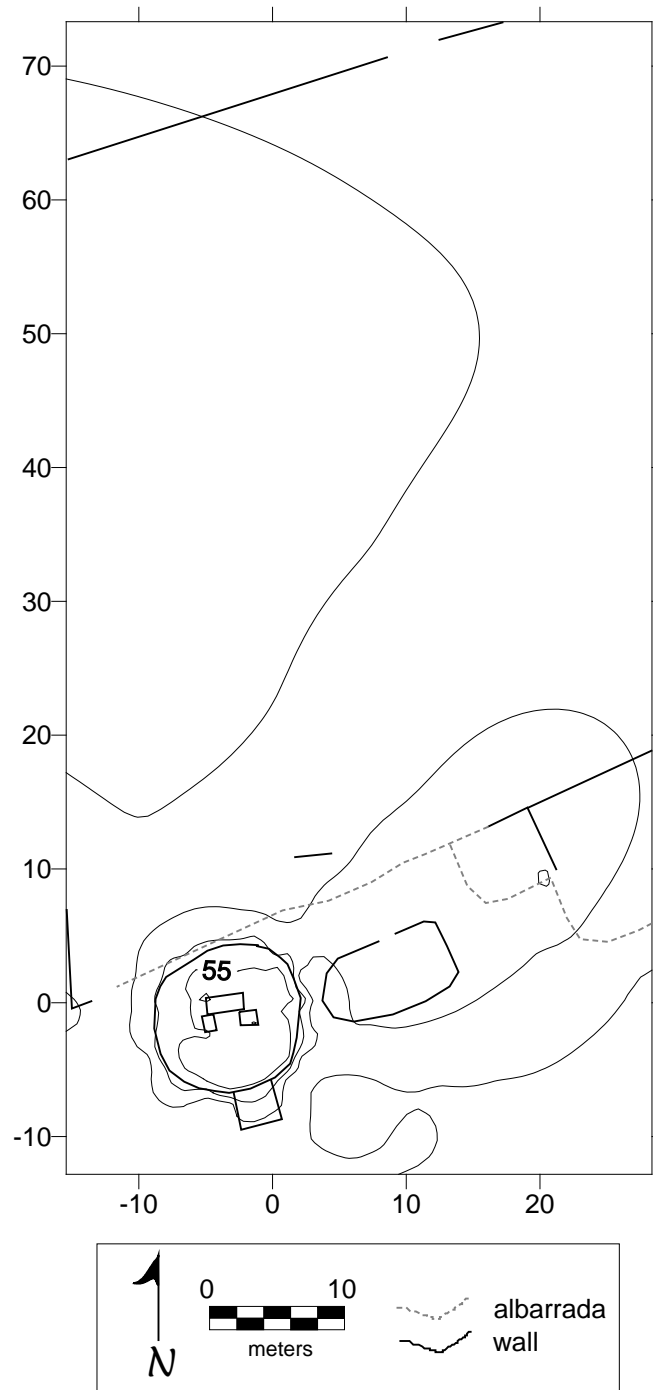

Figure 30. The Site of Pancho Villa

Part 2: The *Ejido* of Saban

Chapter 9: Sak Chikin and Chuunkasin

Johan Normark and Dave Johnstone

The site of Sak Chikin is located 8.5 km southwest of Saban (Figure 31). There is a small cave at the site, located at the bottom of a small hill. The entrance is narrow and inside the passage is less than 50 cm high. Thirty m to the east of the cave entrance is a cluster of three small mounds. No walls could be spotted at any of the mounds. N1E1-1 is the largest of these small mounds.

Five hundred m northwest of Sak Chikin and halfway to Abuelos, there is a site given the nick-name Chuunkasin (Figure 32). There is basically one platform, S1W1-1, that is partially built on a hillock. It supports three smaller foundation braces. In the northwest and southeast corners we find two round structures, S1W1-2 and S1E1-1. A rectangular foundation brace sits on the northern edge of the platform, S1E1-2. It has an entrance that faces inward to the patio. A *chultun* was found nearby.

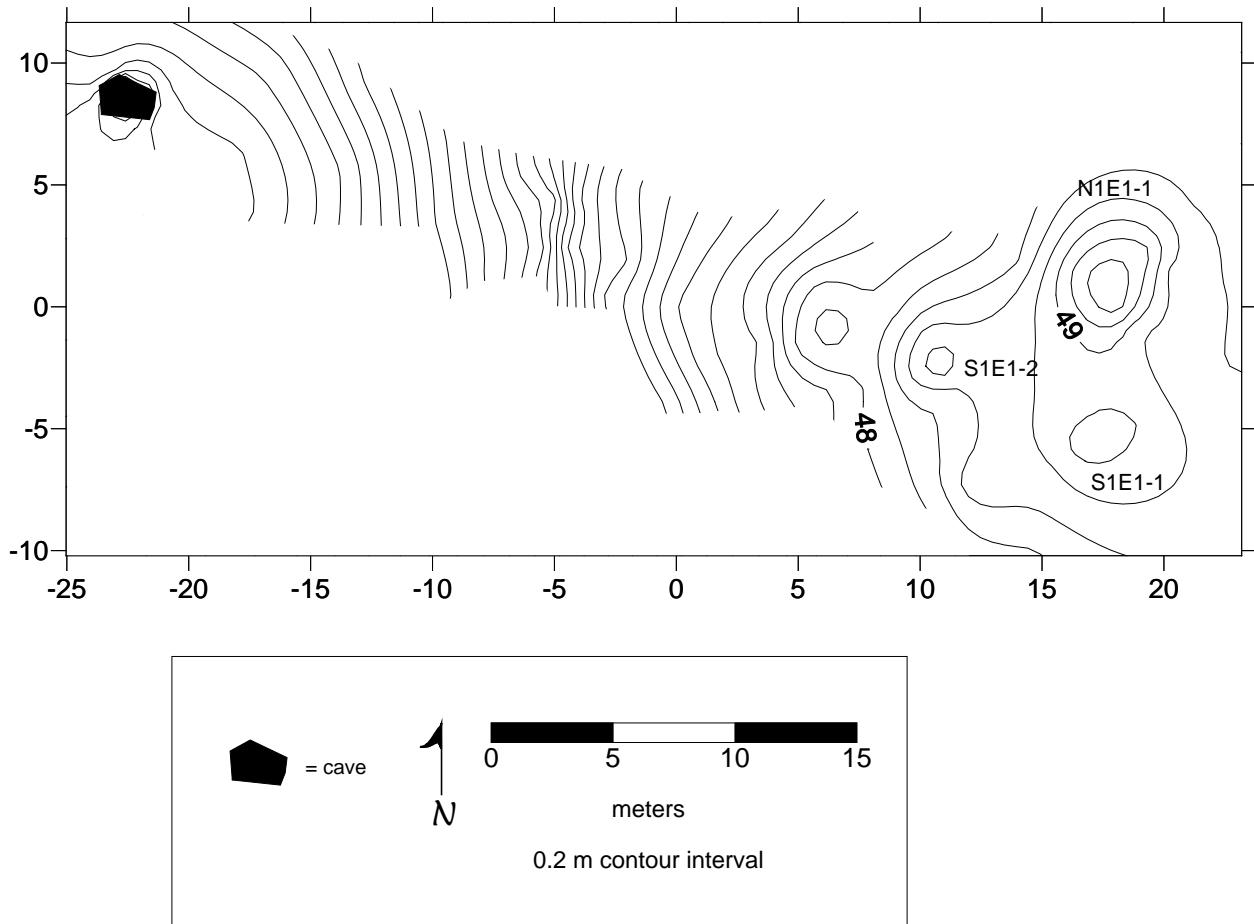

Figure 31. The Site of Sak Chikin

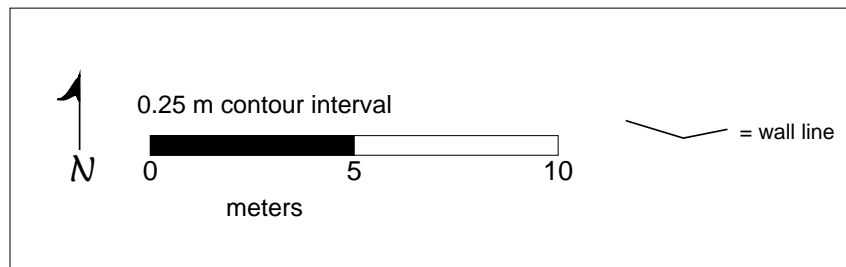
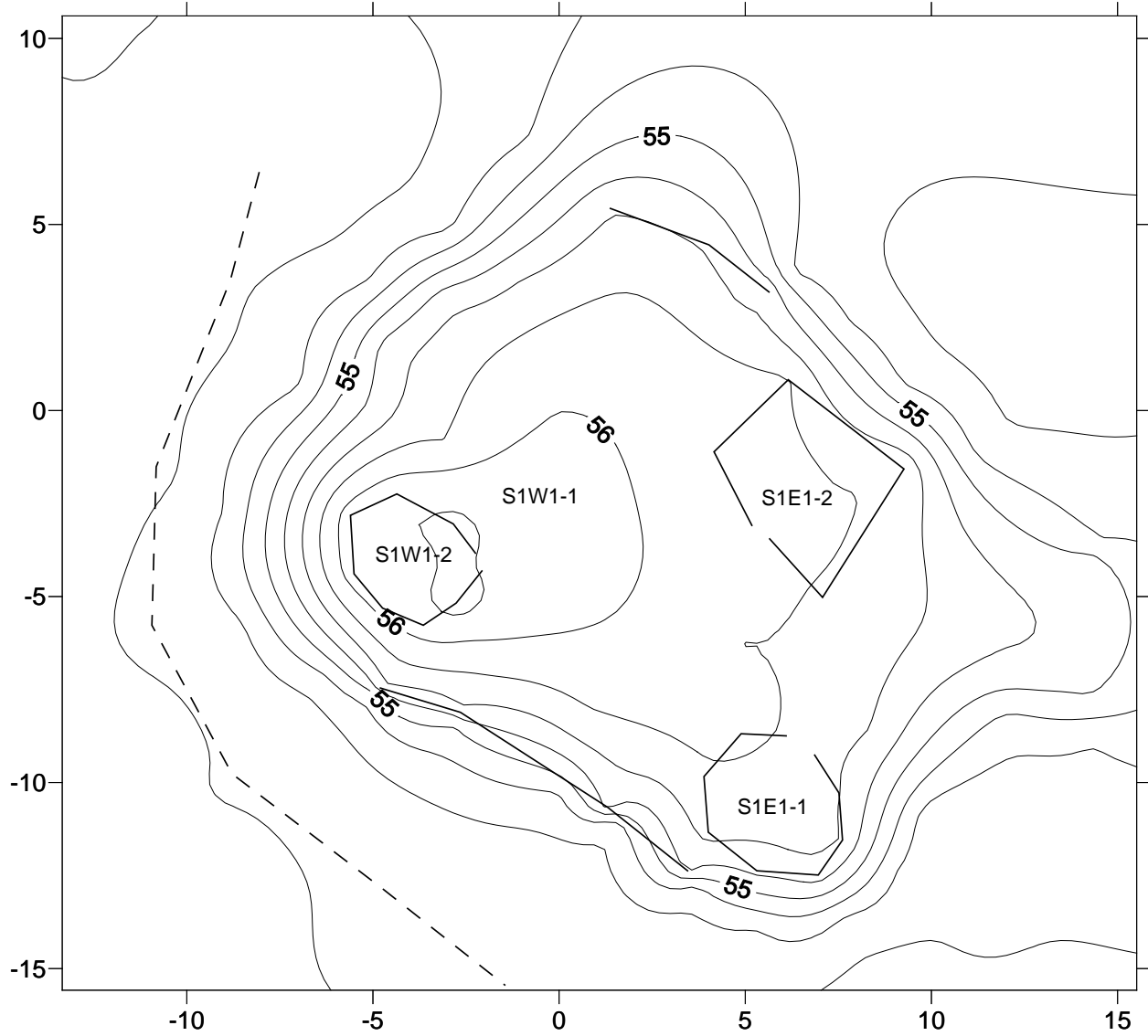

Figure 32. The Site of Chuunkatzin

Part 2: The Ejido of Saban

Chapter 10: Sahcabchen, Operations 1, 2, and 3

Jorge P. Huerta Rodríguez

During the 2008 field season, Structure N1W1-1 of Sahcabchen (Flores and Shaw 2008:79-82) was mapped. The area surrounding the Structure N1W1-1 is relatively flat, with a light slope and covered by abundant secondary vegetation. In order to collect more data to permit us to know and understand the site's occupational sequence, it was proposed to excavate three test pits in different areas of this settlement. These units were 2x2 test pits, placed in the surroundings of Structure N1W1-1, near but not above it in order to not affect the architectural remains visible on surface. The first test pit was dug using 10 cm arbitrary levels within natural levels.

Operation 1

Operation 1 was located 6 m from the southeast corner of the Structure S1W1-1; this operation consisted of three natural levels. Level 1, Lot 1, presented a brown-dark color (7.5R 4/1), and a slight compaction, along with several roots. In consistency this deposit was a silty mixed with a small amount of fine-grained sandstones. The average thickness of this level was 40 cm. Several Terminal Classic sherds, mainly of Yokat Striated and Muna Slate ceramic type were recovered in this level.

Level 1, Lot 2, began at 34 cm deep, and was located in the center of the northern part of the unit, showing a change in color tone and composition. This lot was irregular in shape, and presented a fine-grained consistency, with a thickness of about 5 cm and a reddish gray color (2.5YR 3/2).

Level 2 Lot 1 was a layer of reddish brown color (2.5YR 3/2), with a silty consistency and little compaction. Ceramic samples found in this layer corresponded to the Terminal Classic, mainly of Yokat Striated ceramic type (Figure 33). Level 2, Lot 2 presented a greater compaction, with more presence of sand. The sediment was dark reddish brown (5YR 3/2) in color. Although most of the sherds could not be identified, representative types of this layer are Terminal Classic (Yokat Striated and Muna Slate).

Level 3, Lot 1 was colored a dark reddish brown (7.5YR 2.5/2) and had many stones. Ceramics in this deposit belonged to the Yokat Striated type.

Operation 2

Operation 2 was a test pit located about 13 m of the northeast corner of Structure N1E1-2, and was oriented north-south. No architectural vestiges were visible on surface. Three levels were located in this unit. Level 1, Lot 1 had a reddish brown color (2.5YR 3 / 2), little compaction and a high amount of silt, evident in the high plasticity of the sediment. The thickness average of this deposit was of 9 cm. Culturally it was sterile, and no ceramic fragments were recovered.

Level 2, Lot 1 was also silty, slightly compact, with a reddish brown color (5YR 3/3), slightly different to the previous level, and a low presence of small irregular rocks.

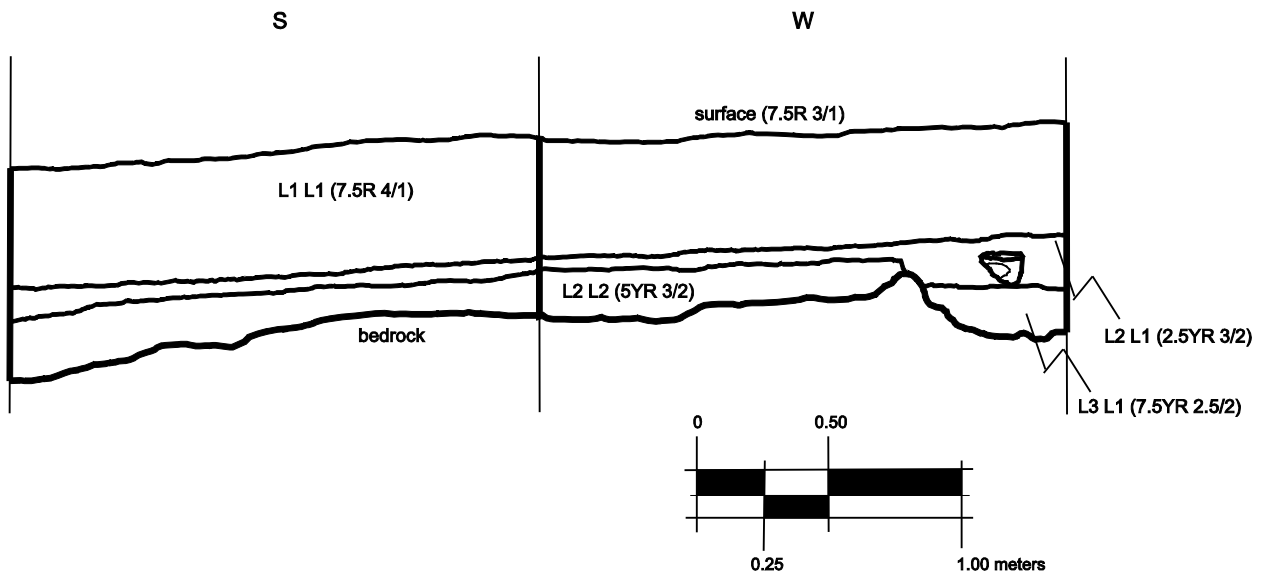

Figure 33. Sahcabchen, Operation 1, South and West Profiles

Only three ceramic sherds were obtained, but not well preserved, hence they could not be identified. The average thickness of this deposit was 13 cm.

Level 3, Lot 1 presented a change in color of the sediment (2.5YR 3/6: dark reddish brown), and a greater plasticity with the presence of irregular rocks, larger than those observed in the previous level (about 10 x 6 cm). Based on the ceramics recovered (of Muna Slate type), it appears that this layer belongs to the Terminal Classic. Once this level was removed, at 64 cm depth, we find the bedrock, which was quite eroded. The western half continued for a few centimeters more, therefore this section was excavated as Level 3, Lot 2. Average thickness of this level was 50 cm.

Level 3 Lot 2, displays a dark brown color (5YR 2.5/2) and was mixed with sandstones of medium to fine sizes, as well as silt. This lot was culturally sterile (Figure 34). As well as Operation 1, we could not find a sealed lot that will permit us to obtain a better data to get a more accurate relative dating.

Operation 3

Operation 3 was a test pit located about 11 m from the northeast corner of Structure N1E1-2, and one meter off the north wall of Structure N1W1-1. The sediment removed from the test pit (mainly *chac luum*, a red silty soil rich on iron) had great plasticity, which hindered the work of digging and screening. Level 1, Lot 1 presented a reddish (10R 3/1) and a silty consistency. Of material recovered from this layer, a single sherd could be identified (of Sierra Red type). The average thickness of this layer was 20 cm.

Level 2, Lot 1 had the same characteristics as the previous level, but with a slight change in color of the soil, reddish brown (7.5R 3/2). The ceramic material recovered included sherds of the types Yokat Striated and Muna Slate, although also a fragment Chen Mul modeled was recovered. The average thickness of this level was 20 cm.

The following deposit, Level 3, Lot 1 had a reddish brown color, which was slightly lighter than the previous level (7.5YR 2.5/2). The sediment characteristics were practically the same as the previous layer. The ceramics identified at this level belongs mainly to the types Sierra Red (Late Formative), Yokat Striated and Muna Slate (Terminal Classic). The average thickness of Level 3 was 10 cm.

Level 3, Lot 2 had the same characteristics of the previous level, except that this layer had small sized sandstones, thereby was excavated as a different lot. This deposit comprised the highest number of sherds of the unit, and was related to the Terminal Classic. The average thickness of this level was 20 cm. Since the terminus of the season was at imminent, in addition to the difficulty of digging and sifting the silty sediment of *chac luum* (red soil), Level 4, Lot 1 was reduced the southern half of the unit, as it was the closest section to the Structure N1W1-1. The sediment was silt, with very small stones and a reddish color (5YR 2.5/3). Within this lot, a different lot. This deposit comprised the highest number of sherds of the unit, and was related to the Terminal Classic. The average thickness of this level was 20 cm. Since the terminus of the season was at imminent, in addition to the difficulty of digging and sifting the silty sediment of *chac luum* (red soil), Level 4, Lot 1 was reduced the southern half of the unit, as it was the closest section to the Structure N1W1-1. The sediment was silt, with very small stones and a reddish color (5YR 2.5/3). Within this lot,

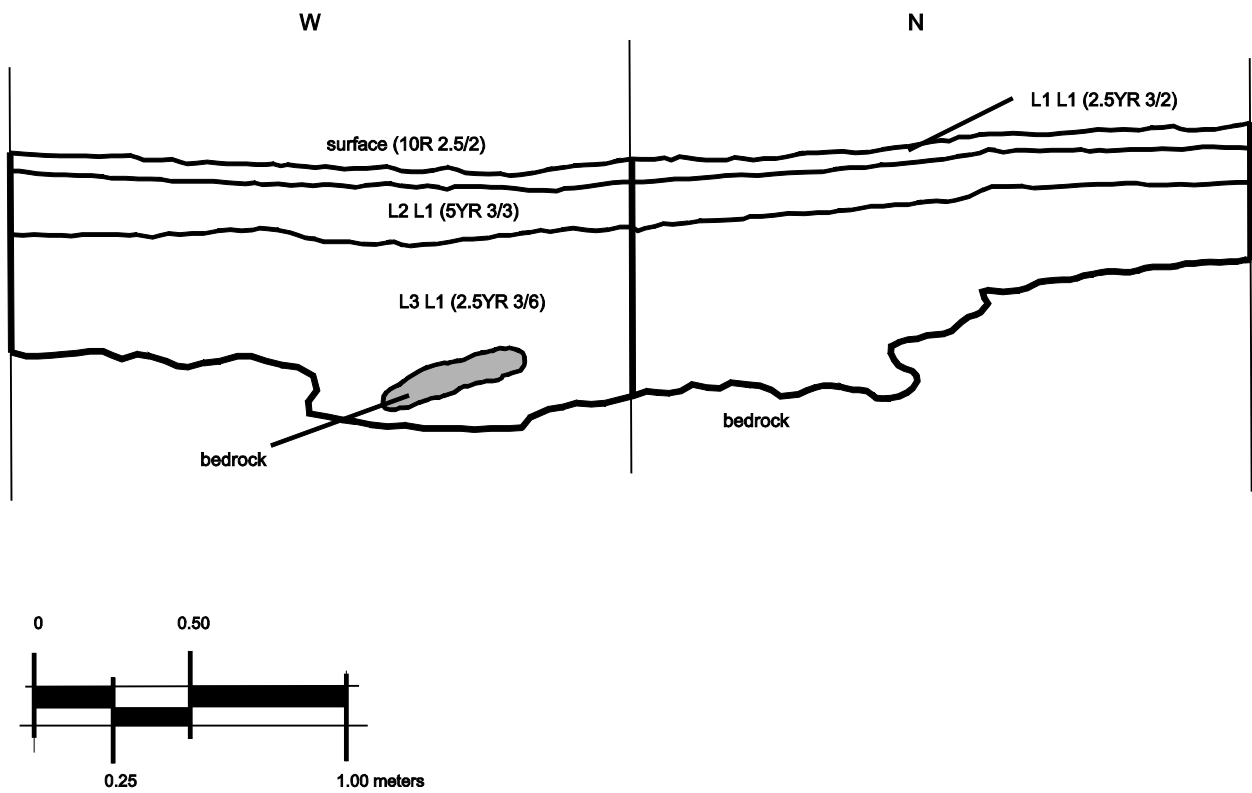

Figure 34. Sahcabchen, Operation 2, West and North Profiles

Chancenote Unslipped and Sierra Red ceramic types were recovered. The thickness of this level was 65 cm (Figure 35). In this operation, no sealed lots were found that will be very helpful to infer a more reliable relative date for the strata.

Interpretation

Operation 1, Level 1, Lot 1 probably corresponds to the layer that has formed during the period since the site was abandoned until the present time. Level 2, Lot 1 and Lot 2 represent perhaps when the site was occupied, and, although no sealed lot was located, based on recovered ceramic samples, we speculate that the site's largest occupation and primary construction episodes took place during the Terminal Classic. Level 3 Lot 1 was probably the first occupational surface of the earliest settlers, being the natural ground surface at that time.

Regarding to Operation 2, Level 1, Lot 1 it seems to be a layer result of a natural deposition process, formed from the abandonment of the site to the present. Level 2, Lot 1 corresponds to the following period to main occupation of this site, due the amount of ceramic samples obtained and their conservation status is likely this area was little traffic. The next level (Level 3, Lot 1 and Lot 2) was probably the first occupation of this settlement. All ceramic evidence points to the site was occupied and perhaps built during Terminal Classic.

Operation 3 confirms the findings of the two previous units. It is necessary to mention the finding of a Postclassic ceramic fragment (of Chen Mul Modeled type), which suggests that there was an activity on the site during this late period, though it may be limited to occasional visits with more religious or symbolic purposes. No other Postclassic evidence was found in all settlement. Besides this, the evidence recovered in this unit indicates a strong occupation during the Terminal Classic.

Although investigations are just beginning, these test pits will help us to understand the development which could have had this settlement, as well as whole region. So far, this is the eastern-most excavated site of our study area. Although a little distant (about 4 km), this site may have been part of Yo'okop polity, and perhaps one of its eastern limits during Terminal Classic, because there is a certain continuity in the settlement from this site to the above mentioned main settlement. It is necessary to extend the survey in the area, to see how Sahcabchen is related with other nearby sites, at least with San Isidro (at 2 km) and Yo'okop (at 4 km) and discern whether it is an isolated settlement, or, as we speculate, part of a large and extended site.

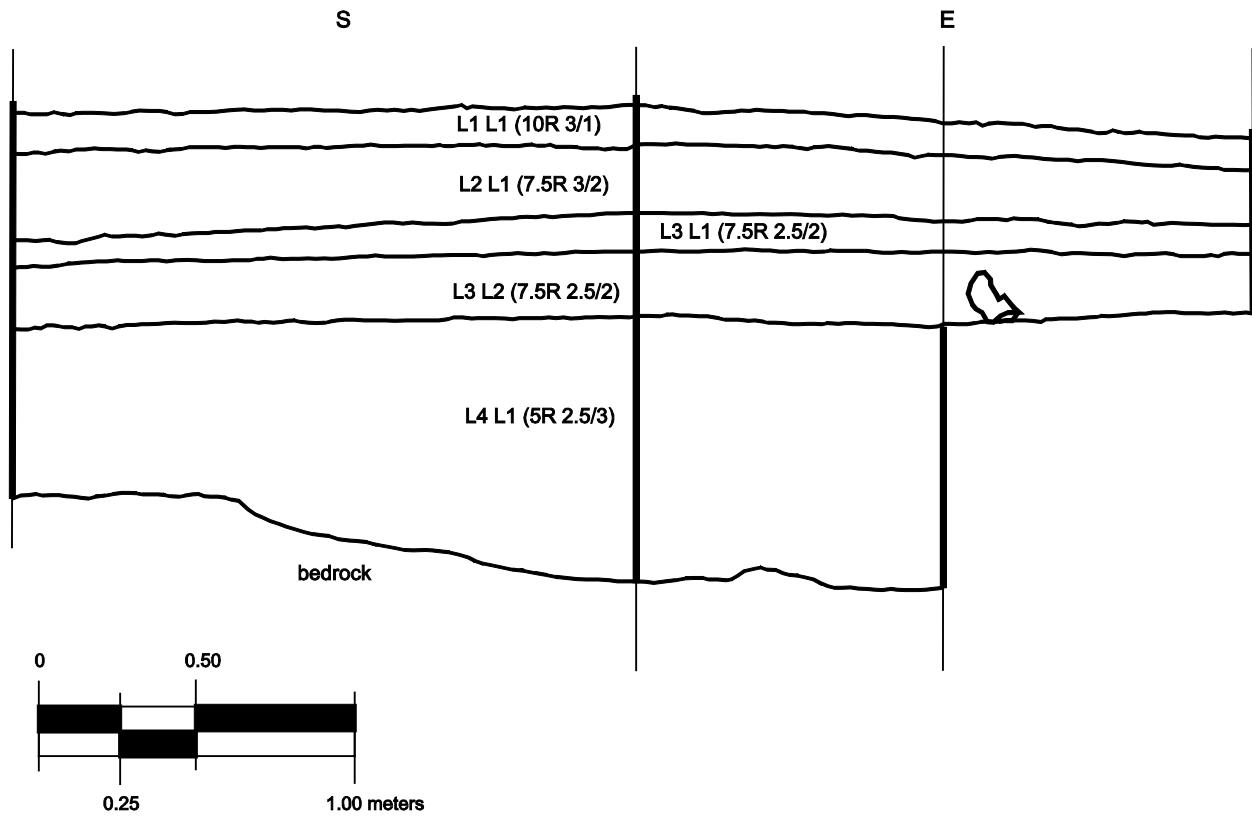

Figure 35. Sahcabchen, Operation 3, South and East Profiles

Part 2: The *Ejido* of Saban

Chapter 11: The Site of San Isidrio, Saban

Justine M. Shaw, Alejandra Badillo S., and Bryce Davenport

The site of San Isidrio, Saban is located approximately 1.5 km to the northeast of the core of the site of Yo'okop (Figure 2). Although the site was visited by Kaeding in 2008, no formal recording of any kind took place until this 2010 field season. The site includes modern, historic, and Prehispanic components located along a modern footpath that begins near Yo'okop's *aguada*. Due to time constraints, only two Prehispanic components of the site were recorded in 2010 (Figure 36); the location of the well, adjacent to an abandoned pole and thatch dwelling on what appears to be a Prehispanic platform, was noted using a GPS.

The southwestern focus of settlement sits atop a modified slight natural elevation known as Structure N1E1-1. The largest structure in the group, Structure N1E1-5, is a rectangular foundation brace atop a small platform on the northern edge of the larger Structure N1E1-1 platform. The two smaller, more pyramidal Structures N1E1-3 and N1E1-6 flank the sides of the foundation brace. Based upon the presence of multiple *pilas*, Structure N1E1-2 may have functioned as a food preparation space. The zone between Structures N1E1-1 and N1E2-1 was not surveyed, although no significant structures were noted by investigators commuting between the two groups. The entire zone had been a *milpa* approximately three years ago, based upon the presence of a corn storage building and the state of vegetation regrowth.

The more northeastern group, on the Structure N1E2-1 platform, is visually dominated by a 2-m mound, Structure N1E2-3. This pyramidal construction was in poor condition, although the remains of a Postclassic shrine are still preserved on its summit. The remains of three rectangular foundation braces, Structures N1E2-2, N1E2-4, and N1E2-5, were recorded elsewhere on the platform. The entire platform was well defined, with intact wall lines composed of large (~50cm or larger), roughly shaped stones. The group lies directly to the west of the modern path, approximately 100 m farther north along the path than the modern house and well complex.

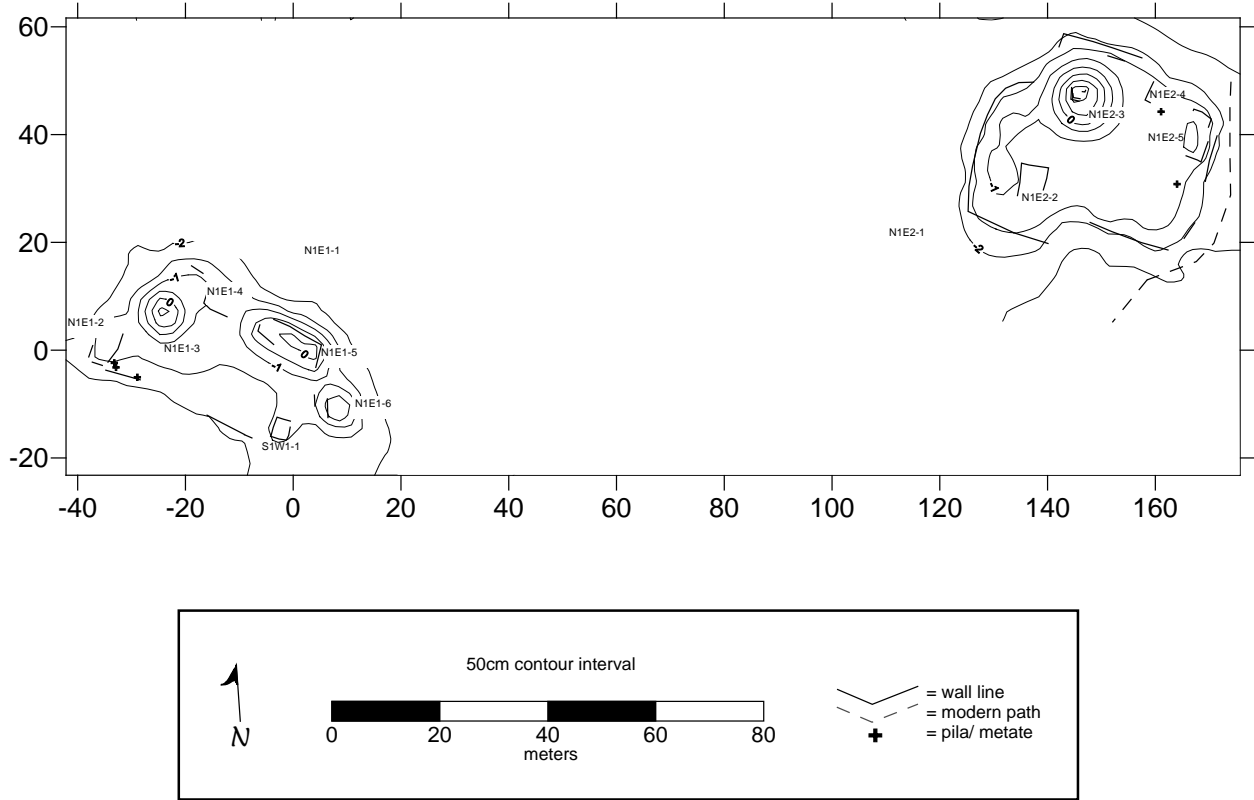

Figure 36. The Site of San Isidro, Saban

Part 2: The *Ejido* of Saban

Chapter 12: The Site of La Trinchera

Alberto G. Flores Colin

The site of La Trinchera is located at 5 km southeast of Saban. It was first reported by the Project in 2008 (Flores and Huerta 2008: 87-89). On that first visit, some structures were located and a sketch without scaling was carried out.

Due to its location, close to the dirt road that connects Saban with Dzoyolá, not many remains of this settlement were left unaltered. A series of road enlargements conducted in recent years have removed some of the structures of the site adjacent to that road. What remains of this site consists of two low platforms, one meter in height (Structure S1E1-1 and N1E1-1), which are crossed by two *albarradas* that seems of recent construction (Figure 37). In the southwestern side of the Structure N1E1-1, nearest to the road, lies a trench that appears to be from the Caste War period. To the northeast, an old well is located, whose curb has been modified in recent times. Although an exhaustive survey could not be conducted, it is probable that this site extends to the southwest, toward the site of Yo'opila, one kilometer away. Whereas a reconnaissance further than the well area was not realized, we propose that the site is more extensive or is part of another larger settlement. Probably Prehispanic ruins near the well have been destroyed or reused in colonial times, historical or contemporary.

During Caste War period, this site may have been one of the fortifications or military positions established by the General Bravo in his campaign against the Maya Rebels (see Chapter 5 this volume). It would be interesting to carry out excavations at this site in order to obtain more data about its role in this period. Although both oral tradition, as well as the evidence of trenches, indicates that this is the place known as "El Pozo" in old military maps and one of the positions of General Bravo (Figure 8), it is crucial to conduct an extensive investigation. If the site of La Trinchera is the position marked as "El Pozo" of General Bravo, means that the adjacent road, which connects Saban with Dzoyolá may be is an old route, perhaps re-used from the Prehispanic period when Yo'okop was the most important site in the area.

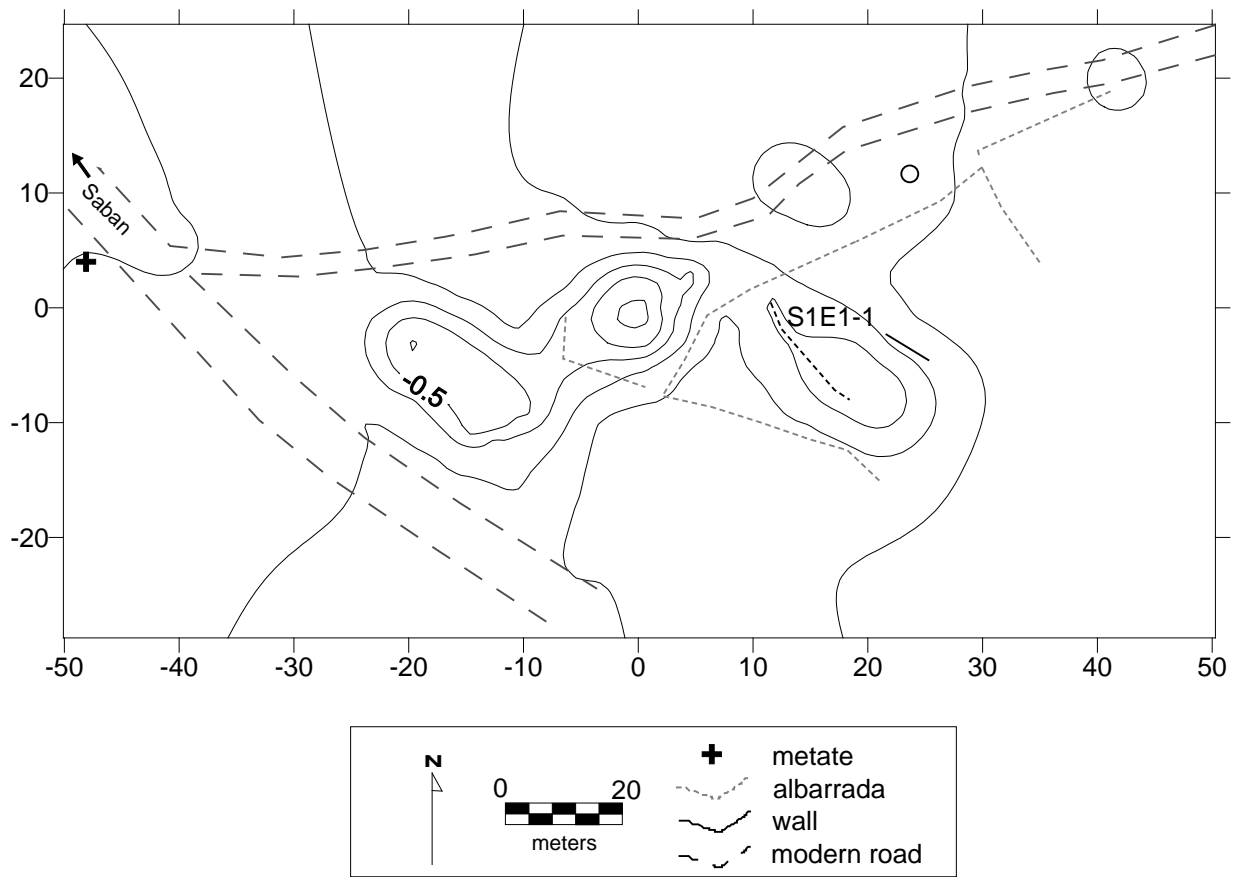

Figure 37. The Site of La Trinchera

Part 2: The *Ejido* of Saban

Chapter 13: The Site of Venadito

Dave Johnstone

Venadito is the center of a modern *rancho*, located 7 km southwest of Saban. We focused our efforts on documenting the central portion of the site which is covered by forest and protected from the periodic burning of the surrounding grass. This protection did not prevent the site from experiencing the effect of looting; especially the taller structures, which often have multiple holes dug into their flanks and summits. Throughout the grass zone is an extensive residential settlement that extends at least 200 m from the site center. This residential zone includes platforms, foundation braces, Postclassic mini-shrines, and Terminal Classic elite residences with mosaic veneer facades (Figure 38) As such, Venadito in many respects resembles Sisal.

The mapped portion of the site is focused on a 1-m-tall platform measuring 50x100 m. Only the eastern portion of this platform and adjacent pyramidal structures were mapped this season. A pit located to the east of Structure S1W1-10 exposes the stratigraphy of the platform. While some larger stones surround this pit, it was not clear if the pit resulted from looting, or from the collapse of the underlying caprock. The profile indicates that the platform was built in a single construction effort, with the standard construction sequence of large boulder dry core fill capped by cobble and pebble sized *chich*, and then plastered. Sherds from the profile were 100% Terminal Classic Slatewares.

The mapped portion of the platform is ringed by a set of structures around the perimeter and is bisected by a line of structures running north-south. This arrangement creates an enclosed plaza. Many of the surrounding structures date to the Postclassic period. Some, like Structure N1W1-4, were built directly on the platform. Others such as Structures S1W1-6 and S1W1-7 are draped over earlier constructions. Still others were capped with mini-shrines at their summits. Structures N1E1-1, S1W1-13, and S1W1-14 had such structures, accessed by stairways that are not oriented with the buildings that they climb.

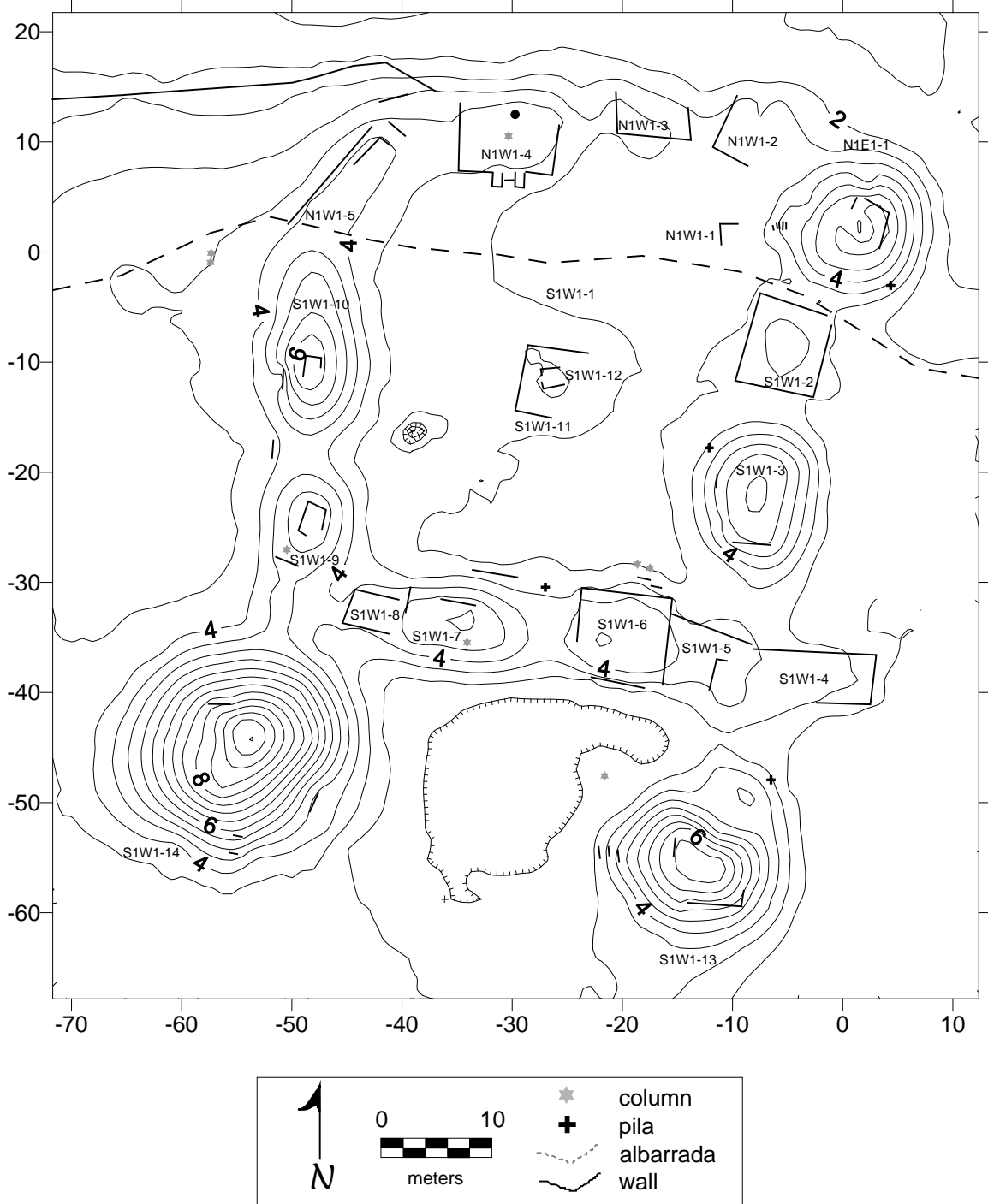

Figure 38. The Site of Venadito

Part 2: The *Ejido* of Saban

Chapter 14: The Site of Yaxche 1

Dave Johnstone

Yaxche 1 is a third-rank site, located 9 km southeast of the village of Saban (Figure 2). Some areas of the site are cleared by a *milpa* plantation; in addition some sections are destined to traditional apiculture. Based on architecture remains observed on surface, there are two obvious occupations in this settlement, one Terminal Classic while other belongs to the Historical or Caste War period.

Terminal Classic occupation is concentrated in an informal plaza surrounded by a series of structures whose fronts are faced to the center of this space (Figure 39). This season also other similar informal plazas were found, surrounded by structures as well, at sites like Xtojil, Ramonal Oriente and La Esperanza. During 2008 another example of these plazas was located in the site of Benito Juarez (Normark 2008). A few meters west, over low bedrock outcrops, other platforms were located, apparently, of residential nature.

Caste War occupation is represented by a well, a corral for horses, and a small pen for pigs connected by an *albarrada*. West of the corral a *sascabera* (quarry for limestone powder) was located. On high ground, two "dry" stone fortifications were located, oriented to the southwest (towards the corral). Because we do not locate the remains of rifle cartridges, it is uncertain whether these fortifications were involved in any combat activity. The well is located west of the corral; it still contains water and is used for farming and the maintenance of colonies of bees.

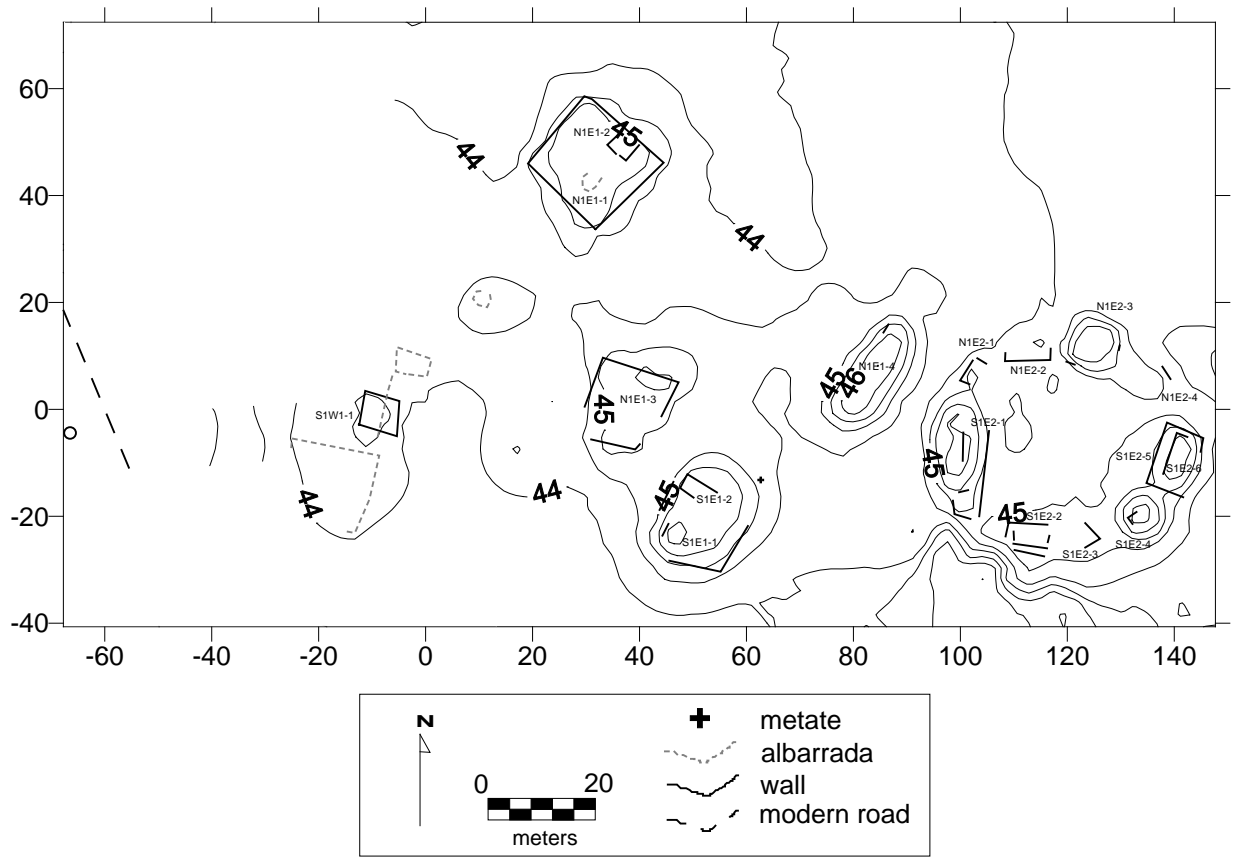

Figure 39. The Site of Yaxche 1

Part 3: The *Ejido* of Sacalaca

Chapter 15: The Site of Ixbaquil

Jorge Pablo Huerta R. and Johan Normark

Ixbaquil is located approximately at 7.50 km northwest of the present village of Sacalaca. The site had already been documented by the Project in previous seasons (Kaeding 2008). Although during the 2008 season only the vestiges of the old historic *rancho* were observed, and were named Rancho Ixbaquil, this site also contains Prehispanic elements. The goal of this season was to obtain a topographic map that includes both Prehispanic and historical remains (Figure 40).

According to information of local informants, this settlement was reused as a farmstead until about 6 years ago. During this period, it was intended for (small scale) livestock activities, such as beekeeping and seasonal agriculture. One of our local crew members worked on this site at that time, and provided us with additional information that allowed us to get a better understanding of the context in which we were working.

It seems that in past this site was a ranch of relevant importance in the region. It contains two wells, several masonry walls, barricades, a jardiniere, a water trough, a drain that connects the trough with one of the wells, two corrals, and a stairway to access the house. These remains are located in the southwest area, with the stairway, which is composed of seven steps, serving as the center of the complex. The total length of this element is three m and is a little more than one m high. Below this stairway are two rectangular holes with a half-circle ending at the top, seeming to be a sort of arch (Figure 41), which probably served to permit the pass of the rainwater to the western area of this feature. South of the first steps, and being a continuation, is another stairway which has remains of a small masonry wall or parapet that bounded both sides. This other stairway leads to a raised plain area with traces of a smooth surface or pavement. We assume that these steps led to the area where perhaps the main rooms were located, but only foundation braces were observed.

A large *albarrada* is on the western boundary, probably corresponding to the western boundary of the main area of the old ranch. The wall that stands to the outside of the stairway is a "twin" wall of which is in the opposite direction, presenting the same dimensions and features. The same alignment continues east becoming an *albarrada*; at its terminus we found a small corral (probably of contemporary manufacture). Upon this wall, east of the stairway, in its western end, a rectangular-shaped water trough is located, built with well cut slabs, without exterior plasterwork, but plastered inside, probably to contain water (very similar to another located at Rancho San Diego, Sacalaca). One of our informants told us that there was another water trough on the west wall, with the same features and dimensions than the one in the east wall. Another detail is the remains of a water channel, carved directly on rock attached to the south wall.

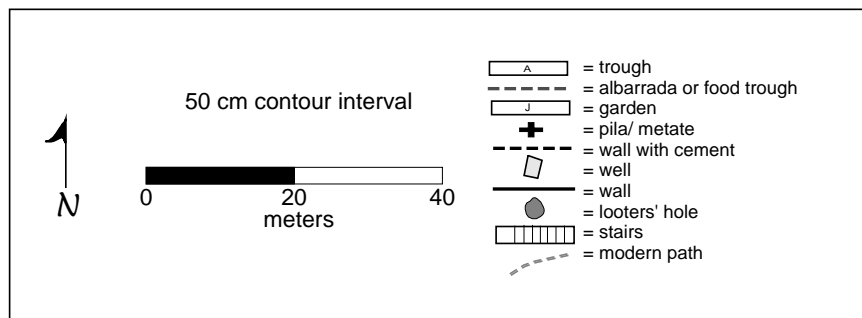
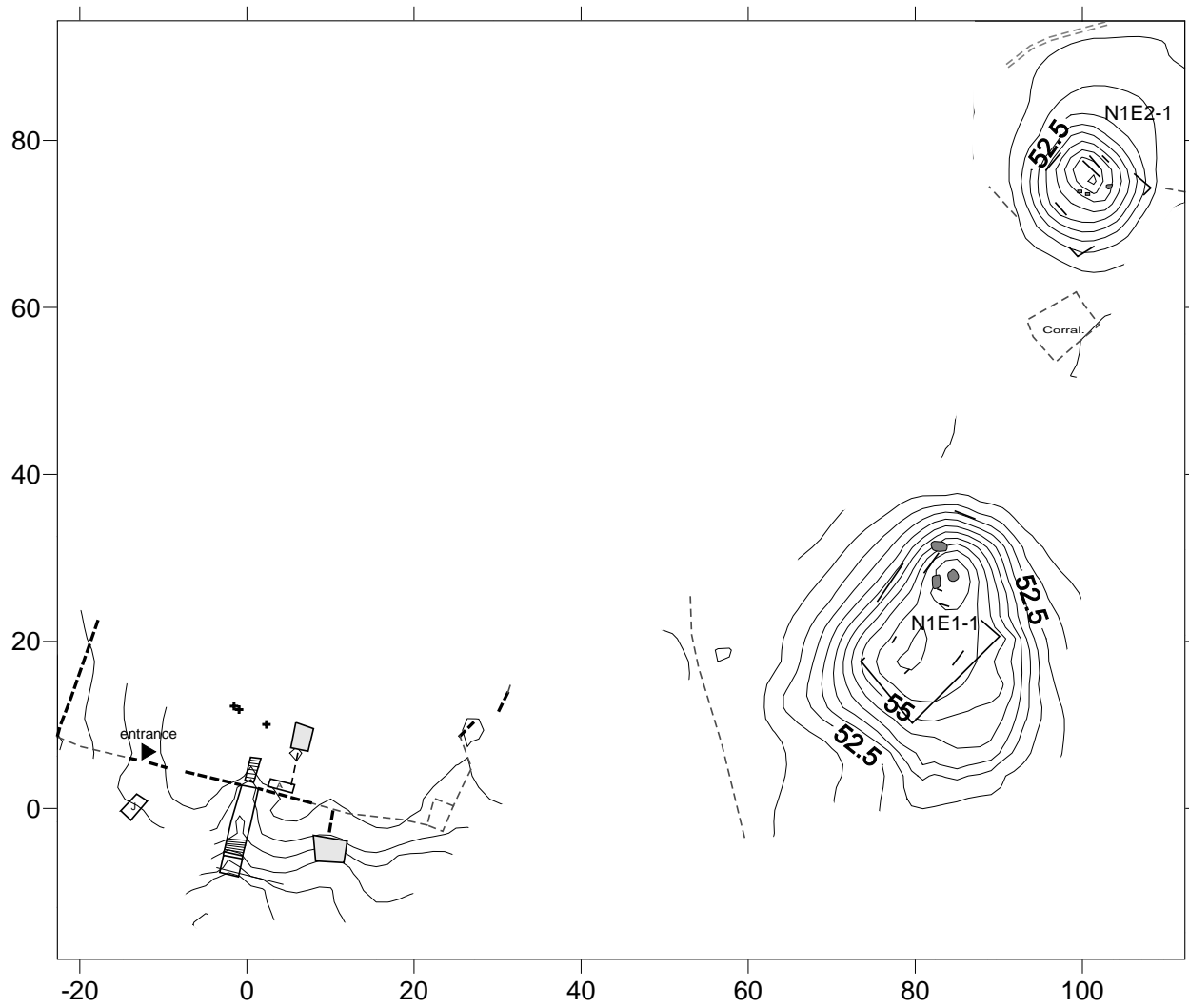

Figure 40. The Site of Ixbaquil



Figure 41. East View of the First Stairway

We also located two wells, one to the northeast and one to the east. The first one, labeled as "north well" (see Chapter 47 in this volume), has a rectangular shape and has two post that supports a beam, still plastered although in poor condition. In this area four "*pilas*" or *metates* are located, three of which are Prehispanic while the other seems to be more recent. There is a channel, about 4 m long, that connects the north well with the water trough, built with stones reused from one of the a Prehispanic structures nearby. The south well has a rectangular shape, built with piled rocks that comprise it. Apparently, there was also a wall with a channel between the well and the second trough, which is no longer evident. Neither well has a long casing, because they are built on the same natural *cenote* (sink hole).

To the northeast, 115 m north from the well, is a corral delimited by a series of *albarradas*, which has an irregular shape, although this element perhaps is of recent construction. There are another sets of *albarradas* in several parts of the settlement, although not were recorded this season.

With regards to the Prehispanic ruins, about 42 m northeast of the north well, two platforms are located (Structure N1E1-1 and Structure N1E2-1). Structure N1E1-1 is built on a natural outcrop of limestone. The shape of this building is well preserved, and appears to be composed by several stepped layers. At its summit, the remains of some foundation braces are located, all with different orientations, which make us assume that this building had more than one superstructure, perhaps from different periods. Two looters' holes were found in the northern part of the top of the structure.

Structure N1E2-1 is located about 40 m northeast of Structure N1E1-1. This pyramid-shaped building, reaches a height of about 4 m, and maintains the same alignment as the Structure N1E1-1. This building is situated in an apparently leveled area. Although in very poor condition because it has three looters' holes and all its sides are collapsed (Figure 42); it is still possible to see some architectural details, fragments of walls, including two corners of the base, as well as remains of foundation braces.

Due to time constraints, additional elements were not registered; these exist mainly towards the south area of the settlement, where apparently there are several Prehispanic platforms. The map made this season contains the most remarkable features. It is necessary to conduct test pitting in order to obtain data that allow us to know the probable phases of occupation that had this settlement.



Figure 42. South Façade of Structure N1E2-1

Part 3: The *Ejido* of Sacalaca

Chapter 16: Parcela Escolar, Operations 2 and 3

Tatiana Zelenetskaya Young

Location of the Test Pits of Parcela Escolar

During the 2010 field season, two test pits, Operation 2 and Operation 3, were excavated at the site of Parcela Escolar (Figure 43). The purpose of the excavations was to recover ceramic samples in order to estimate the periods during which the site and plaza were constructed and occupied, as well as determine the nature of the plaza.

A plaza is a space deliberately left open. People need to benefit from the open space (plaza) or they will neither agree to build it or leave it open. A plaza can be public, private, formal or informal. A public plaza is open, has easy access for entering and no restrictions. The Great plaza of Chichen Itza surrounded by three building complexes, El Castillo, the Ball court and the Temple of Warriors, as an example of a public plaza. Private plazas usually are smaller and have restricted access. Restricted place is area which is less accessible, blocked by some structures or walls creating narrower entrance and more “privacy”. A private plaza is a manifestation of higher ranking status, wealth and prestige. It displays the gap between rulers and ruled (Awe, Campbell, and Conlon 1991). Plazas are an important spatial display of the social hierarchy of a society. One need to have a power and means to build a plaza, and to surround an area for restricted access to build structures.

Public plazas can be formal or informal. Formal plaza is not incidental plaza; it is planned and being in accord with established forms and conventions. Formal plazas are purposely surrounded by structures, while these structures are arranged according to a certain order. One needs to have power to command people to build their houses to surround a plaza. The construction of a formal plaza requires a large amount of the labor, time and people. An authority with enough power must be present to control a project as well. Ruling elite were in control of ancient plazas (Guderjan 2007:20). Informal plaza is not organized, not structured or planned, suited for everyday use. Informal plazas would be created by chance or by some random constructions.

Plazas can have many functions. Ceramic vessels illustrate activities that an ancient Maya performed at plazas (Reents-Budet 2001:196). Plazas were arenas for political function and decision making (Martin 2001:168). Plazas were used for rituals and ceremonies performed by the rulers or elites to appease gods, theatrical performances and dances to unite communities, presentations of historical events to express political power relationships, also games and festivals. A plaza at the large sites may play a role as a place where tribute was received (Martin 2001:178). Plazas are dynamic and can change or loose their meaning through time. For example, today Sacalaca people gather together around the plaza, watching teams of girls playing soccer.

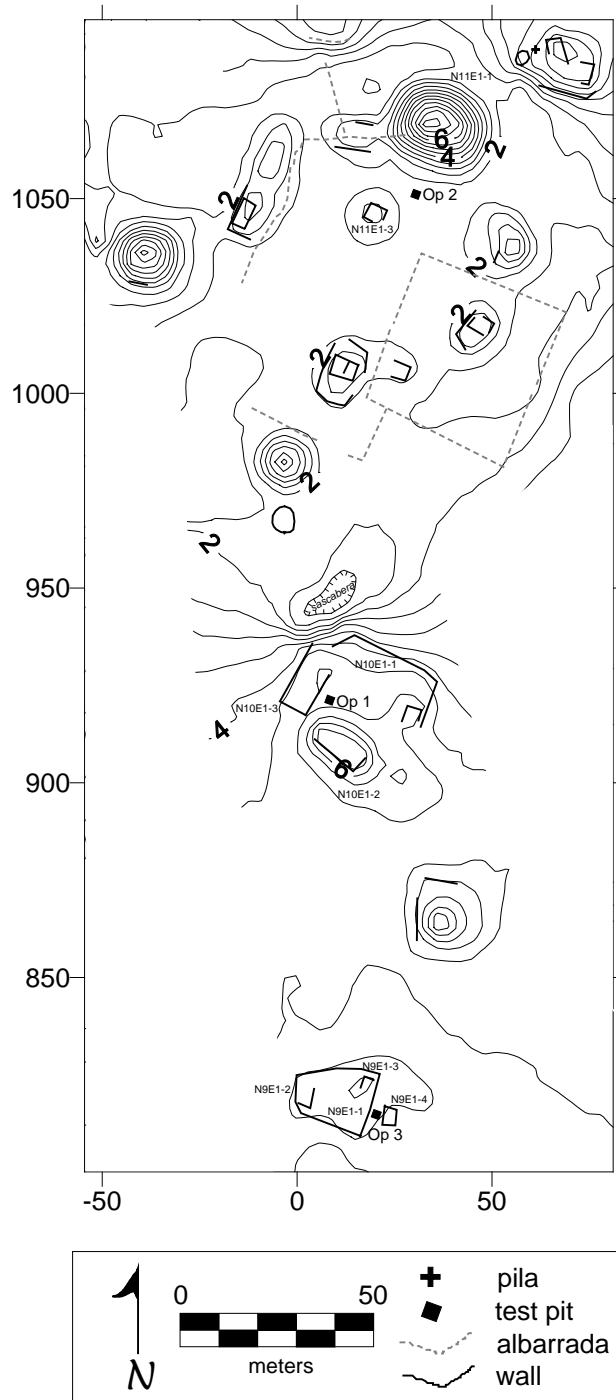

Figure 43. Location of Operations 2 and 3 at Parcela Escolar

The purpose of Operation 3 was also to recover ceramic samples in order to estimate periods, during which the site was occupied. An additional aim was set to date the platform - the Structure N9E1-1, and the smaller Structure N9E1-4, located eastward from the platform.

In combination with the data from the test pit collected during the 2005 field season, Operations 1, 2 and 3 serve to permit understanding of the occupation and construction time periods, ranking of the site, and political organization of the Parcela Escolar.

Parcela Escolar Operation 2

Operation 2 was a 2 x 2 meter test pit positioned on the plaza, between Structure N11E1-3 and mound N11E1-1. A pyramidal mound can be viewed as a pile of artificially raised platforms of pyramidal shape that usually support such constructions as temples (Shaw et al. 2000:44). The tallest pyramidal mound at the site of Parcela Escolar, the Structure N11E1-1, exhibits no structure on the top. Actually the top of the mound does not appear to be leveled; it is probable that the mound had been looted and has a pit on the summit or was not finished.

Operation 2 was aligned to the north cardinal direction and located about 3 meters away from the base of Structure N11E1-1. All lots of Operation 2 were excavated as natural levels. The surface of the test pit was composed of dark sediment (5 YR 2.5/1) and organic material. Surface collection yielded no ceramics.

Level 1, Lot 1 contained *box luum* soil (black soil) with stones of 5-10 cm diameter and many roots, yielding sherds and one lithic flake. The ceramics in this lot were dated to the Early and Terminal Classic Periods.

At approximately 20 cm depth below the surface the sediment changed to a more reddish color (5 YR 3/3); and angular gravel about 3-5 cm in length and 1-3 cm in width. In Level 1, Lot 2 the quantity of sherds stayed the same as in lot 1: about one sherd per two buckets. The ceramics in this lot were a mix of the Late Formative, Late Classic and Terminal Classic Periods. Additionally, Level 1, Lot 2 produced four spelioliths about 3-4 cm long and one cm in diameter. Presence of spelioliths points out that a fill for the plaza was brought from some other location at the site. The areas from which a fill was brought could be any sheltered place with environment rich of permeating minerals; this kind of environment allows growing of spelioliths. Such environment present at caves or *sascaberas*.

At about 58 cm in depth from the surface the quantity of sherds decreased, and *sascab* (decomposed limestone) cobble sized pieces were present. Level 1, Lot 3 witnessed an increase in the quantity and size of ceramics. The sherds became larger and thicker, yielding at about three sherds per bucket. These dated to the Middle Formative, Late Formative, Early Classic and Terminal Classic Periods. Level 1, Lot 3 was finished due to the change of sediment to dark red color (2, 5 YR 3/6), approximately 100 to 110 cm in depth from the surface.

Level 1, lot 4 yielded similar quantities of ceramics: about 1-3 per bucket. The ceramics were a mix of the Middle Formative, Late Formative and Terminal Classic Periods. Approximately 135 cm from the surface the matrix became culturally sterile. Bedrock was exposed all over the test pit, appearing at a depth of approximately 147-151 cm below the surface.

In whole, ceramic analysis of Operation 2 indicated a construction phase during the Terminal Classic Period.

Profiles of the north and west wall were completed (Figures 44 and 45). The formation processes of Operation 2 were both cultural and natural. It includes purposeful and accidental discard of objects during construction of the plaza. The purposeful discard is represented by the fill which was brought for construction of a surface of the plaza. On other hand, a natural accumulation of sediment is present too. Profiles of Operation 2 exhibit no floor present at the plaza, which suggests that the plaza at the site has informal nature.

Parcela Escolar Operation 3

Operation 3, a 2 x 2 m test pit, was located between the platform N9E1-1 and Structure N9E1-4. This place was chosen because rubbish typically accumulates between the platform and the foundation brace. This platform located at the center of the naturally raised area. The platform is raised from 50 cm to one meter above surrounding terrain and has megalithic blocks present on three sides of the platform.

Excavation proceeded in natural levels. Excavated lots were positioned horizontally, 1 x 1 meter in size, for more controlled excavation. The surface of the test pit of all 4 lots was covered by dark sediment (5 YR 2.5/1) and produced no ceramics.

Level 1, Lot 1, produced a small amount of ceramics and reached the bedrock from approximately 27 to 52 cm of depth from the surface. Level 1, Lot 2 exposed the bedrock at a depth of approximately 27 to 40 cm, and also produced a small quantity of ceramics. Level 1, Lot 3 yielded a similarly small amount of sherds and was terminated after reaching the bedrock in all corners at about 25 to 39 cm from the surface level. Level 1, Lot 4 also yielded a small quantity of sherds and exposed the bedrock in all corners from 18 to 48 cm in depth from the surface. The matrix of all 4 Lots of Level 1 was dark reddish brown (5 YR 2.5/2). Excavated ceramics in all lots were purely of the Terminal Classic Period; therefore, the time of occupation of Operation 3 was dated to the Terminal Classic Period. Perhaps, this area was built fast to accommodate a growing population at the site.

Profiles of the north and west wall were completed (Figures 46 and 47). The formation processes of Operation 3 seem to be more natural than cultural. There is no purposeful discard of artifacts at the test pit area. The rubbish just accumulated through the time. Profiles exhibited that residences N9E1-4, N9E1-5 and N9E1-6 were built on top of the bedrock without usage of any artificially raised material.

Discussion of Findings from the Operation 1, Operation 2 and Operation 3

During the continued investigation of the site of Parcela Escolar, three test pits were conducted at different parts of the site in order to achieve a fuller understanding of construction phases and occupation timeline of the site. In additional aim was to gain better understanding of the site layout and political organization of the site of Parcela Escolar.

Operation 1 (2005) was located at the artificially raised platform in the corner between two structures; N10E1-2 and N10E1-3. Operation 1 was performed in order to date the occupation span of the site and also indirectly date the structures (Young

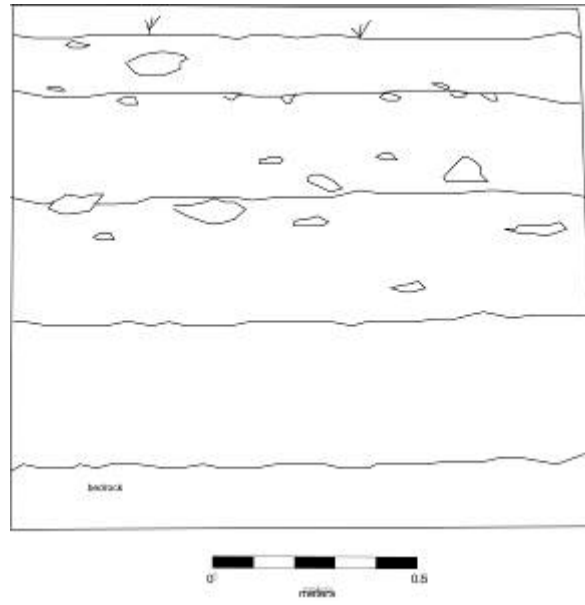

Figure 44. Parcela Escolar, Operation 2, North Profile

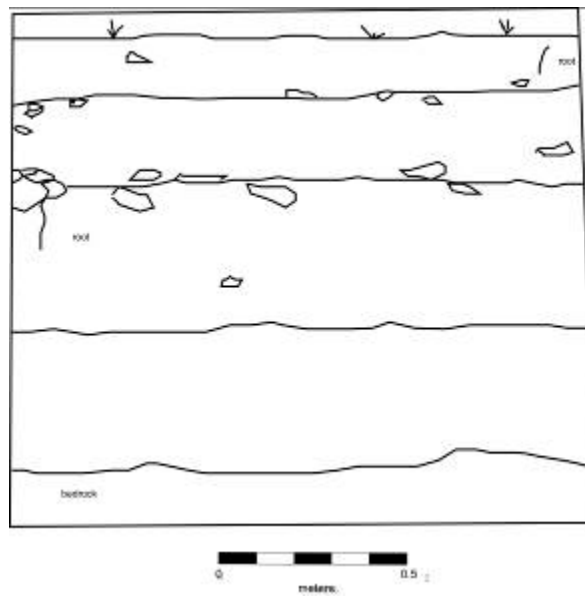

Figure 45. Parcela Escolar, Operation 2, West Profile

2005). These two structures were located on platform N10E1-1. Platforms are artificially raised terraces which provide level surface for building of residential structures (Shaw et al. 2000:43). The two structures - N10E1-2 and N10E1-3 - located on the platform appear to form a semi-enclosed court or patio; and, most likely was a residential area. The platform is about 1.5 m in height, and probably hosted an elite residence due to an amount of collapse material present at the structure. One of the structures – the Structure N10E1-2 may have been vaulted residence according to an amount of stone debris and the relative thickness of the walls.

Ceramic analysis indicated Terminal Classic Period occupation with limited number of sherds from the Late Formative, Early Classic, and Late Classic Periods (Young 2005:118-120). The profiles of Operation 1 exhibit presence of *chich* (small pebbles) fill and a large amount of boulders beneath the *chich* which is indicative of the floor. The floor itself did not survive due to human damage and exposure to the natural elements. The formation processes of Operation 1 were cultural and natural. Artificially raised platform inquires energy input for bringing big boulders and covering it by small *chich* for a floor foundation. However, a floor itself underwent a natural process of weathering and disintegration over the time.

Operation 2 was positioned in the plaza near the tallest mound of the site. The absence of a plaza's floor, elite housing, walls or other constructions, which would bind the space around the plaza, indicates that the plaza is informal. The plaza also does not have restricted access, which points out that it was not a private plaza. The surface of plaza was constructed during the Terminal Classic Period. As it mentioned above, the presence of spelioliths suggests that a fill for the plaza was brought from caves or *sascaber*s. The presence of a *sascab* deposit on the Formative Period sherds, discovered during the excavation, suggests that some of the sherds came from *sascaber*s. *Sascaber*s were used for the mining purposes to acquire necessary building material for project construction. *Sascaber*s could be also used as a dump for the garbage by ancient inhabitants, then later would be mined to obtain a building material and a fill for construction. The occurrence of a large amount of sherds from the Formative Period suggests sturdy occupation during this time. A large amount of sherds in *sascaber*s or caves points out that a primary deposit of the Formative Period probably is located somewhere in the site of Parcela Escolar or where brought from nearby sites. A similar context (*sascab* deposit on sherds) was discovered at the site of San Pedro (ejido of Sacalaca) (Johnstone 2005:181).

Operation 3 was situated on the surface between a platform and a house. The platform N9E1-1 and Structure N9E1-4 were in all probability constructed by kin members who used elevated area in order to conserve energy and labor costs. In fact, at least three more similar constructions were discovered in west part of the site. During the 2010 field season a 200 meter long transect was made originating from Structure N11W1-1, to the location of Operation 3, revealing at least two more artificially raised platforms (Figure 48). The platforms were positioned almost directly south from the smallest pyramidal mound (about 2.5 m tall), Structure N10W1-1. The platforms were relatively tall, about one meter in height. The large stones, about 50-70 cm in length and height, constitute the foundation of the platforms. It appears that the platforms had perishable structures because quantities of collapse stones were not sufficient for elite residences.

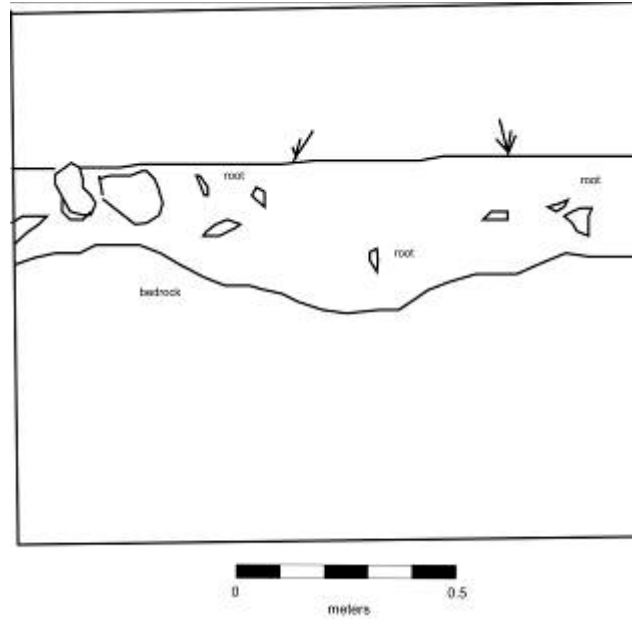

Figure 46. Parcela Escolar, Operation 3, North Profile

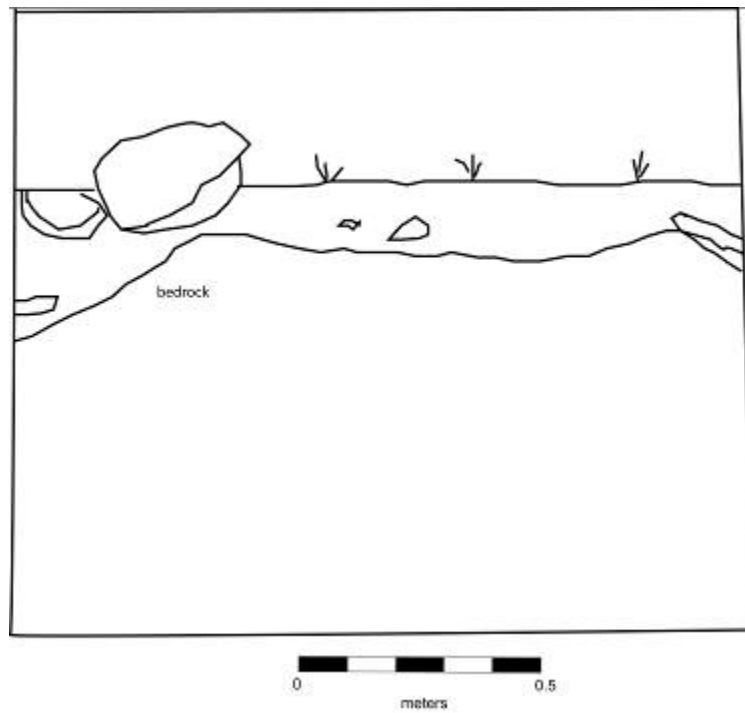

Figure 47. Parcela Escolar, Operation 3, West Profile

other. Both platforms were facing to the northeast cardinal direction. Just behind the platforms to the west a large *sascabera* was located. Additionally, one more large platform was visible (though not cleared) toward the west. It is probable that the platforms were built by kinship members and were family residences because non-elites could not afford to have laborers build for them. The transect and the platforms were not mapped during this season due to time constraints.

In order to understand relationship between sites, settlements are ranked. Consequently, to rank settlements a four-tiered hierarchical site classification can be applied. Class Four sites include foundation braces for the perishable structures and residential platforms. Class Three consists of foundation braces and residential platforms and also pyramidal mounds- 4-6 m. in height. Class Two includes all features mentioned in Class Three plus vaulted residences and palaces. Class One includes features present in Class Two, plus has pyramids higher than 10 m height, acropolii, formal plazas, hieroglyphic monuments and specific features such as intersite *sacbeob* and ballcourts (Johnstone 2006).

In conclusion, although the Middle Formative and Late Formative Periods ceramics were discovered during excavation, there are no associated constructions of these periods at Parcela Escolar. Correspondingly, there are only a few sherds from the Early and Late Classic Periods with no associated constructions of this time at the site. The occupation during these periods might be found elsewhere at the site. The site of Parcela Escolar experienced a peak of occupation and construction during the Terminal Classic Period. The exposed terrace wall of the Structure N11W1-1 permits us to date this mound to the Terminal Classic Period. The results from analyzed ceramics dated the construction of plaza at the site of Parcela Escolar to the same period. In fact all excavated constructions at the site date exclusively to the Terminal Classic Period. During this period Parcela Escolar oversaw constructions of new structures and perhaps extension of the site. The presence of 6 meters tall pyramid and possible elite residence, residential platforms, absence of a formal plaza consign the site of Parcela Escolar is the Rank Three site.

During the Terminal Classic period (750 -1,050 A.D.) the Maya civilization experienced transformation in its setting. This period oversaw migrations, changes in populations and politico-economical spheres. The Terminal Classic Period could be considered a time of transformation: of power and of societies - some cities faded while others arose. The most noticeable change was visible in the disintegration of the political hierarchy of divine lords during this time period in the Southern Lowlands. The Maya “collapse” is best-associated with this period.

During the Terminal Classic Period neither formal nor public plazas were present or constructed at the Parcela Escolar. The presence of an informal plaza in the site implies decentralization of power. Construction of public and formal plazas necessitates the control of the masses and labor, also organization of elite’s houses or other constructions to surround a plaza. The construction of these types of plazas requires a ruler to supervise the process. However, the Rank One site of Yo’okop has at least one formal plaza present during this time. The presence of an informal plaza and elite residence could point out to the political decentralization during the Terminal Classic Period at the site of Parcela Escolar.



Figure 48. Two platforms South of Structure N10W1-1, Parcela Escolar

Part 3: The *Ejido* of Sacalaca

Chapter 17: The Site of Ramonal Oriente, Sacalaca

Dave Johnstone

Ramonal Oriente is located 5.2 km northeast of Sacalaca on the path to Xbalcheil. It was documented in 2003 (Flores 2003) and sketch mapped in 2004 (Flores 2004). Like many sites in the study area, the site contains both historic and prehistoric elements, with the historic being the smaller and more ephemeral of the two.

The historic constructions consist of a dry well, *bebederos* (drinking troughs) and *albarradas* (field walls) usually associate with ranchos located towards the northeast portion of the site (Figure 49). The well itself is of interest as it lacks a collar or masonry neck. It is uncertain if this results from it being unfinished, from accidental collapse, or deliberate destruction. The *albarradas* enclose, or are built onto, earlier Prehispanic structures. These are platforms with associated residential foundation braces. Structure S1E1-3 was built using cut veneer stones, suggesting a Terminal Classic construction date. This is commensurate with a small surface collection taken from the largest platform N1E1-1. Interestingly, this platform is faced on its north and west sides with megalithic stones set vertically. The use of megalithic stones has been tentatively dates to the Late Formative to Early Classic transition. However, the vertical placement is somewhat unusual.

A second architectural group was mapped some 250 m to the southwest (Figure 50). At present it is unclear if this group is tied to the rancho group as part of continuous settlement. The second group consists of an informal plaza and nearby pyramidal structure. Unlike Venadito, it was not clear if this plaza is raised on a low platform. What is clear is that there are at least two periods of construction: one dating to the Terminal Classic, and the second to the Postclassic. The Terminal Classic structures are larger in scale, and are of a more formal arrangement than the Postclassic constructions. Structures N1W1-1, N1W1-2, S1W1-1, S1W1-3/4 and S1W1-12 all appear to date to the Terminal Classic and employ veneer stones in their superstructures. Structure S1W1-4 is an example of open fronted architecture from late in the Terminal Classic; following the collapse. Five Postclassic mini-shrines were constructed atop these earlier structures.

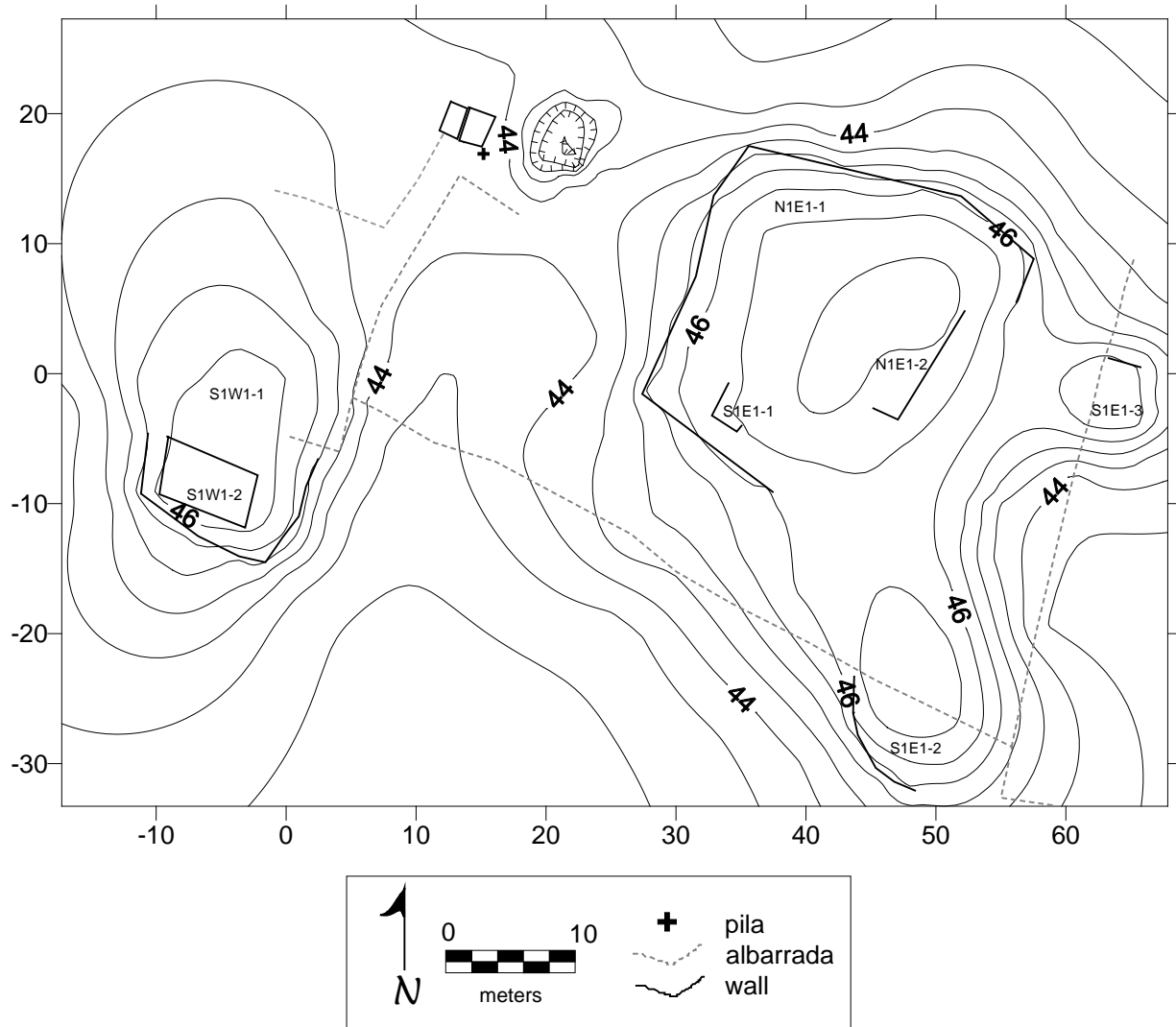

Figure 49. The Northeast Portion of the Site of Ramonal Oriente, Sacalaca

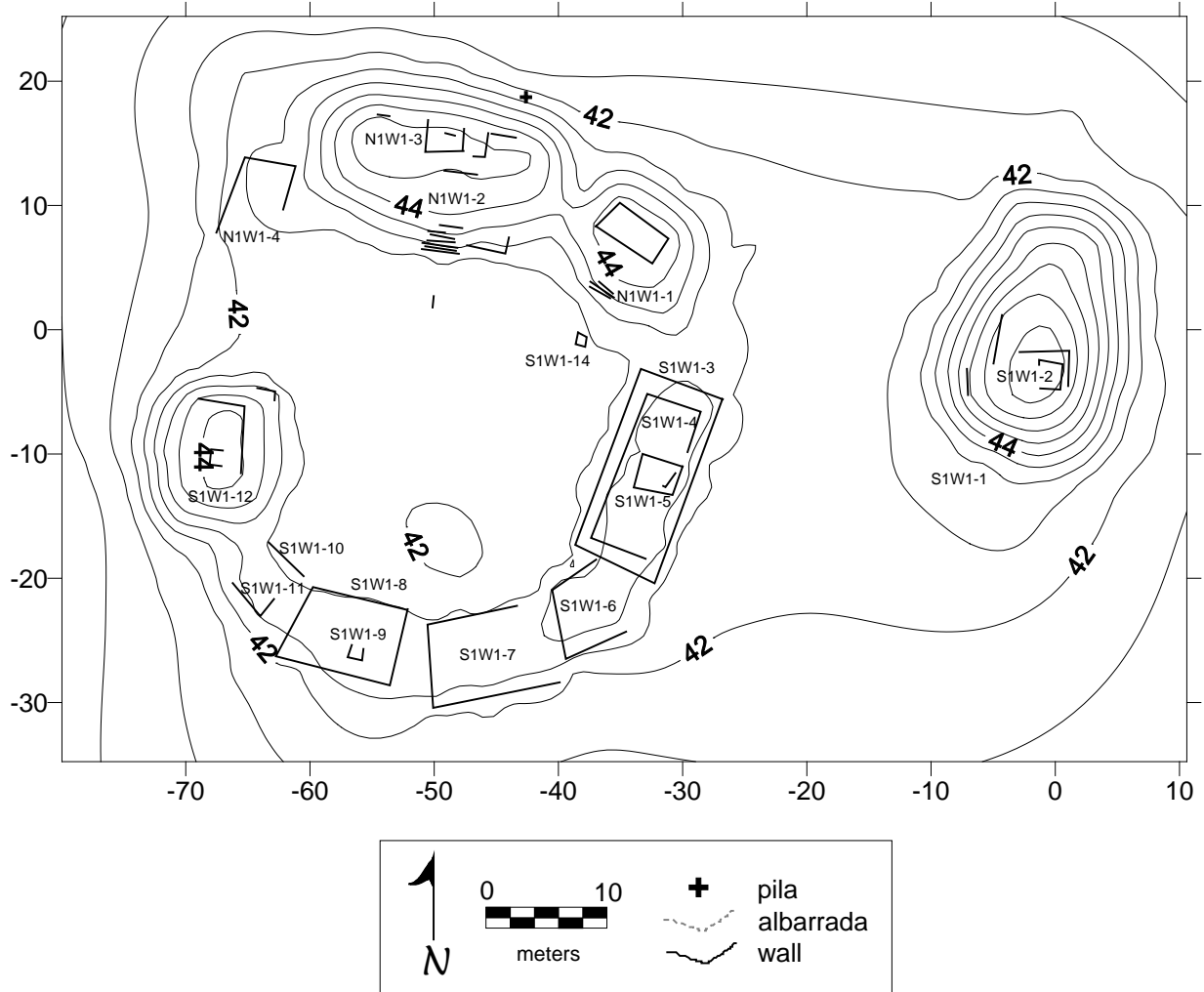

Figure 50. The Southwest Portion of the Site of Ramonal Oriente, Sacalaca

Part 3: The *Ejido* of Sacalaca

Chapter 18: The Site of Rancho San Diego

Jorge Pablo Huerta R.

Rancho San Diego is located about 3.4 km southeast of the village of Sacalaca; in previous seasons this settlement was visited by members of the Project (Huerta R. 2008), when several Prehispanic and Historical vestiges were reported.

During this season the map of the site was carried out (Figure 51). Historical remains that were documented includes: a well, a major corral, a water trough, a jardiniere, as well as the remains of an *albarrada* and a masonry wall. The historical cluster is located in the western part of the settlement, where the topography does not present relevant unevenness, but is not completely flat. The corral is bordered by several *albarradas* and has an almost rectangular shape; access is located on its east side and in the central area there is a masonry wall which has, at its center, a small square hole. Embedded in the wall, on the west side, stands a rectangular water trough built with well cut stones that still retains parts of its interior plasterwork (Figure 52). In the eastern part of the wall, there is evidence of a channel or duct that conducted water from the well to the trough. The well is located about 10 m southeast of the corral. Near the well, two *pilas* or *metates* are located, which appear to have been brought to this point in recent times. About 14 m from the water well, a jardiniere or plant plot is located. There are, in different directions (east, north and northeast of the corral), several remnants of *albarradas*, probably part of the corrals for livestock or delimited areas for different crops, probably to the main activity of this historic settlement.

The Prehispanic remains found in this site are comprised of three small structures, one pyramid-shaped (Structure N1E2-1) and two platforms (Structures N1E2-2 and N1E2-3). The terrain in the area is rougher than on the historical *rancho*. No more structures were located because of the overgrown vegetation in the area, and by the little time more time assigned to the recognition of this site. Structure N1E2-1 is located at the eastern end of the settlement and has an irregular shape (19 x 17 m) with a meter and a half in height. Atop is a small, square-shaped Postclassic shrine, consisting of regular-shaped rocks (Figure 53). Structure N1E2-2 is located about 14 m northwest of the Structure N1E2-1 and is a rectangular platform 1.5 meters in height. This building had the most deterioration of the whole site. Atop, on the east side, there is an alignment of rocks belonging to an *albarrada*, which has no connection to either of the sides of the building.

Structure N1E2-3 is a small rectangular platform with a height of less than a meter. It is located at the center of the two other structures described above. This entire group lies on level ground, probably of cultural origin and seems to have been a square or plaza. The alignment of these three structures is 15 degrees east of magnetic north.

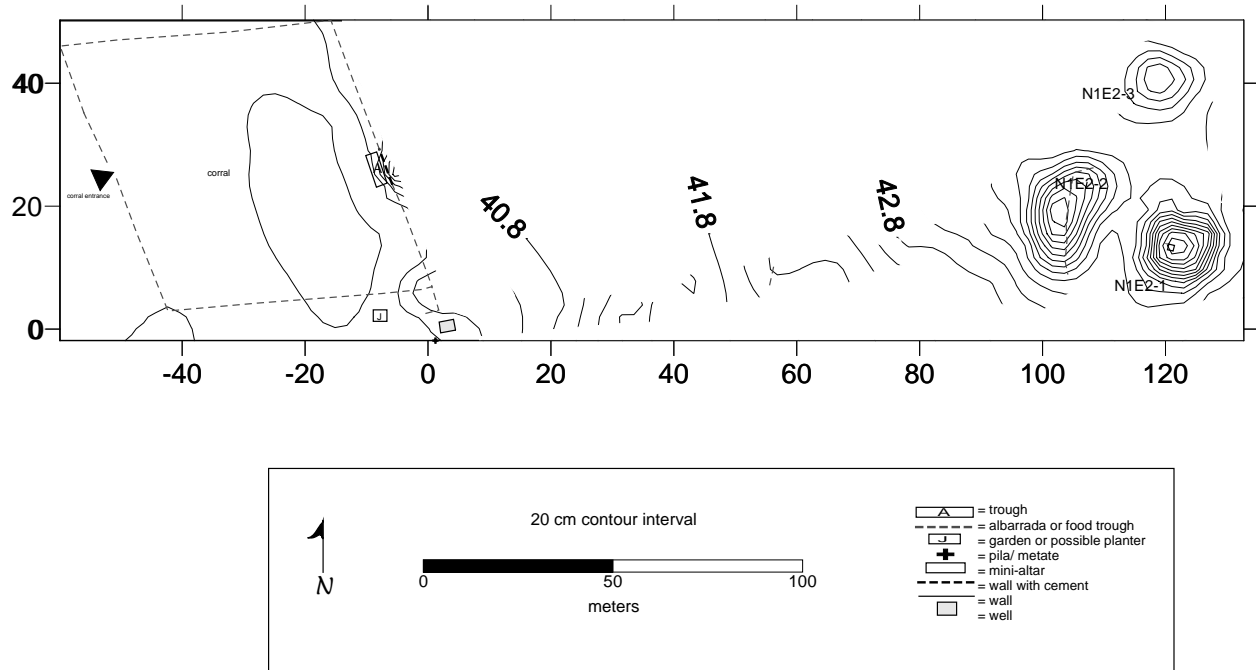

Figure 51. The Site of Rancho San Diego, Sacalaca



Figure 52. Water Trough at Rancho San Dleno



Figure 53. Postclassic Shrine at Rancho San Diego

Although it seems that the site was occupied during the Postclassic, it seems that the structures were built in an older period (probably during the Terminal Classic). It is necessary to conduct several test units in plaza areas to gather data that allow us to know about the different occupations that may have had this settlement. Surely, an extensive survey will reveal more structures and will help to get a better understand about the organization of this site.

Part 3: The *Ejido* of Sacalaca

Chapter 19: The Site of Rancho San Isidro

Jorge Pablo Huerta R. and Dave Johnstone

This settlement is located 4 km southwest of the present town of Sacalaca. Locals have known that this has been permanently occupied in recent times. The rancho is dedicated to the corn agriculture and cattle raising; in 2008, Project members conducted a reconnaissance of the area in which a small Prehispanic platform was located (Huerta 2008). The topography is quite rugged, due to several limestone outcrops.

The historic ranch area (Figure 54), delimited by an *albarrada*, is about two hectares, but within the perimeter, in its northeast extreme, there is a rectangular corral of about 70 square meters. The well is located south of the corral. The *albarrada* that delimits the corral is in good condition, has access on the north, south, as in the northwest corner. In the southwestern extreme, there is a small square-shaped corral of about 4 x 4 m. This feature could have been used for raising sheep or other minor livestock. In the southern part of the corral, at the center and delimiting it are the vestiges of a wall, broken into three parts and with remains of its original plasterwork (mainly at the bottom). In one of these fragments and perpendicular to the well, there are two troughs. The largest is located on the north side of the wall; this trough probably corresponds to the original occupation of the ranch, because has the same kind of plaster that the one on the wall. The smaller trough lies on the south side of the wall. By its appearance, it is likely that this element is not contemporary to the above mentioned trough and seems to have been recently made or has had a permanent maintenance that covers the old characteristics. It has to be noted that there are three square-shaped holes in the wall located between the old trough and the well. Drawing a straight line among both elements, it is easy to deduce that these orifices had the purpose of supplying of water to the trough (Figure 55).

West of corral, a small Prehispanic mound was located (Structure S1W1-1). It was surrounded by a lot of sherds that unfortunately, like the structure, were in a poor state of preservation. Structure S1W1-1 is about one meter height, and is crossed by the *albarrada* that delimits the zone of this *rancho*. In this area are several outcrops of bedrock; the structure was placed on top of one of them, taking advantage of the elevation. On the south side of the base of the structure, a shallow *sascabera* was located, while on the east side, at about a meter, we found a *haltún* which has an almost circular in shape, with a depth of 40 cm.

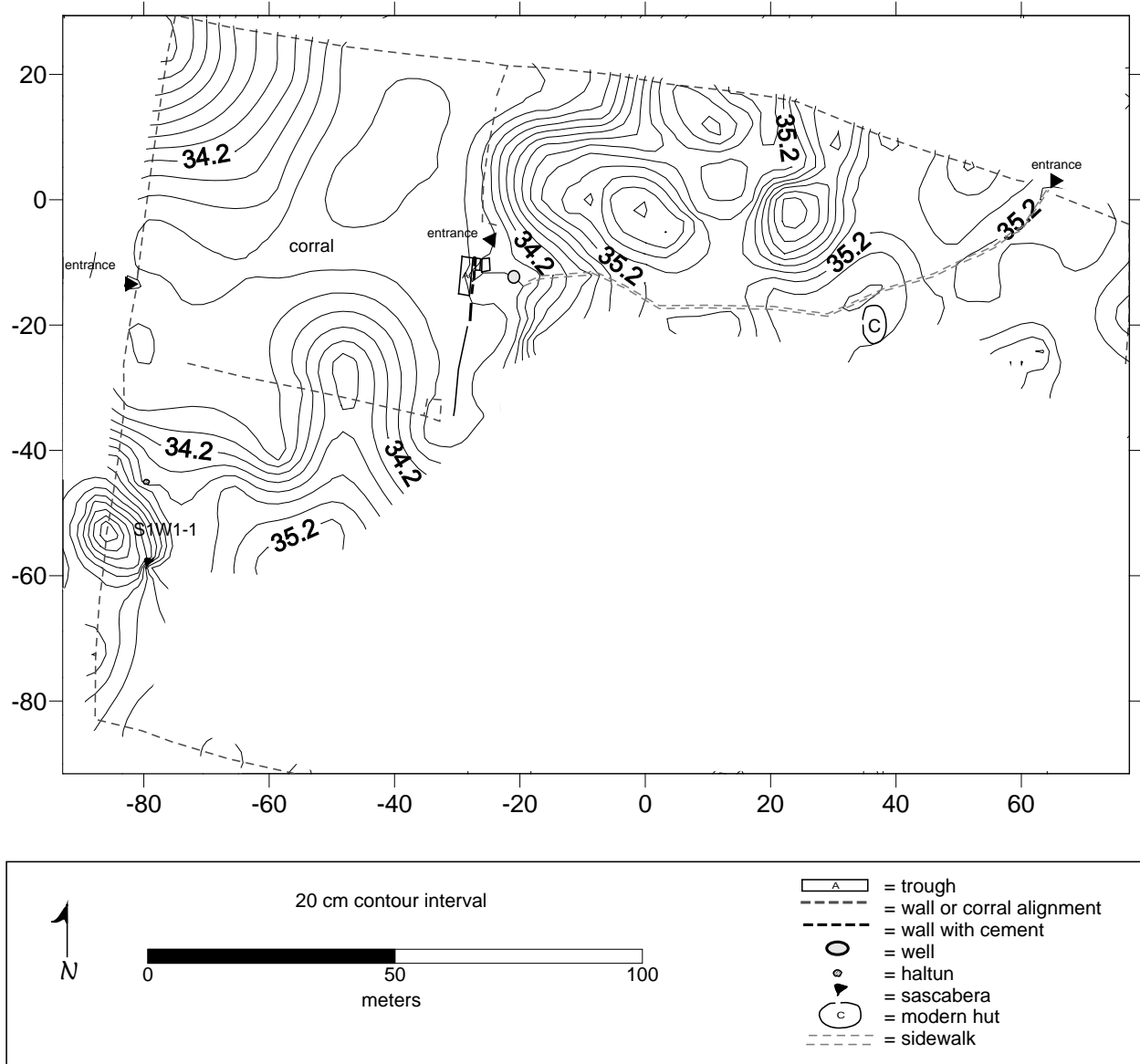

Figure 54. The Site of Rancho San Isidro



Figure 55. Detail of Colonial Wall, Viewed from the Well

Part 3: The *Ejido* of Sacalaca

Chapter 20: The Site of Rancho San Juan

Jorge Pablo Huerta R., Dave Johnstone and Johan Normark

Rancho San Juan is located northwest of the present village of Sacalaca. It had been visited in previous seasons, but it wasn't until this year that a plan map of this site was made (Figure 56). According to locals, the site was occupied continuously until recent times. This site consists of both Prehispanic and historical elements; like most old ranches in the region, it has been reused in different periods.

With regards to Prehispanic vestiges, the site has three low platforms (Structures N1E1-1, and S1W1-1, and S1E1-1). The three structures sit on a plateau and have a high degree of deterioration. Structure N1E1-1 is located north of the complex and has an average height of one meter. Atop this platform, there are remnants of several apsidal foundation braces, whereas in the lower west side, there are vestiges of a small wall that may have been the eastern limit of the base of the platform. South of Structure N1E1-1, at a distance of 16 m, Structure S1E1-1 is located. It is a small platform with the remains of several apsidal foundations braces, as well as the vestiges of walls of small dimensions, which are probably the original walls of the structure. About 23 m southwest of this structure, Structure S1W1 was located. This building is the one with a greater degree of deterioration, because the last occupant of the site built a perishable house at the top. Several well cut stones were also observed in the vicinity of this structure, mainly to the northeast. These elements were also observed in modern perishable house (Figures 57 and 58). In the southwestern portion of the site, there are traces of an *albarrada*, and to the north the remains of a rock alignment that would correspond to the walls of the base of this building could be observed.

Among the historical vestiges on the site are fragments of *albarradas*, a well, a planter and a corral. Fragments of the *albarrada* are found mainly around the core area of the ranch, probably indicating its limits. According to our surface survey in 2008, it is likely that the ranch occupied an area of about five hectares (Kaeding 2008: 123-125). A well, round in shape, is located in the southwest quadrant of the site; it has the remains of a plaster coating on the outside and inside of the curb. One-half meter to the southeast of the well is a square-shaped element, which is composed of well cut stones and has no visible plaster coating; thus, we speculate that it was a planter.

Twenty m northeast of the well, a small pen or corral, rectangular in shape at about 7 x 6 m, was found; its entrance is in its northwest corner.

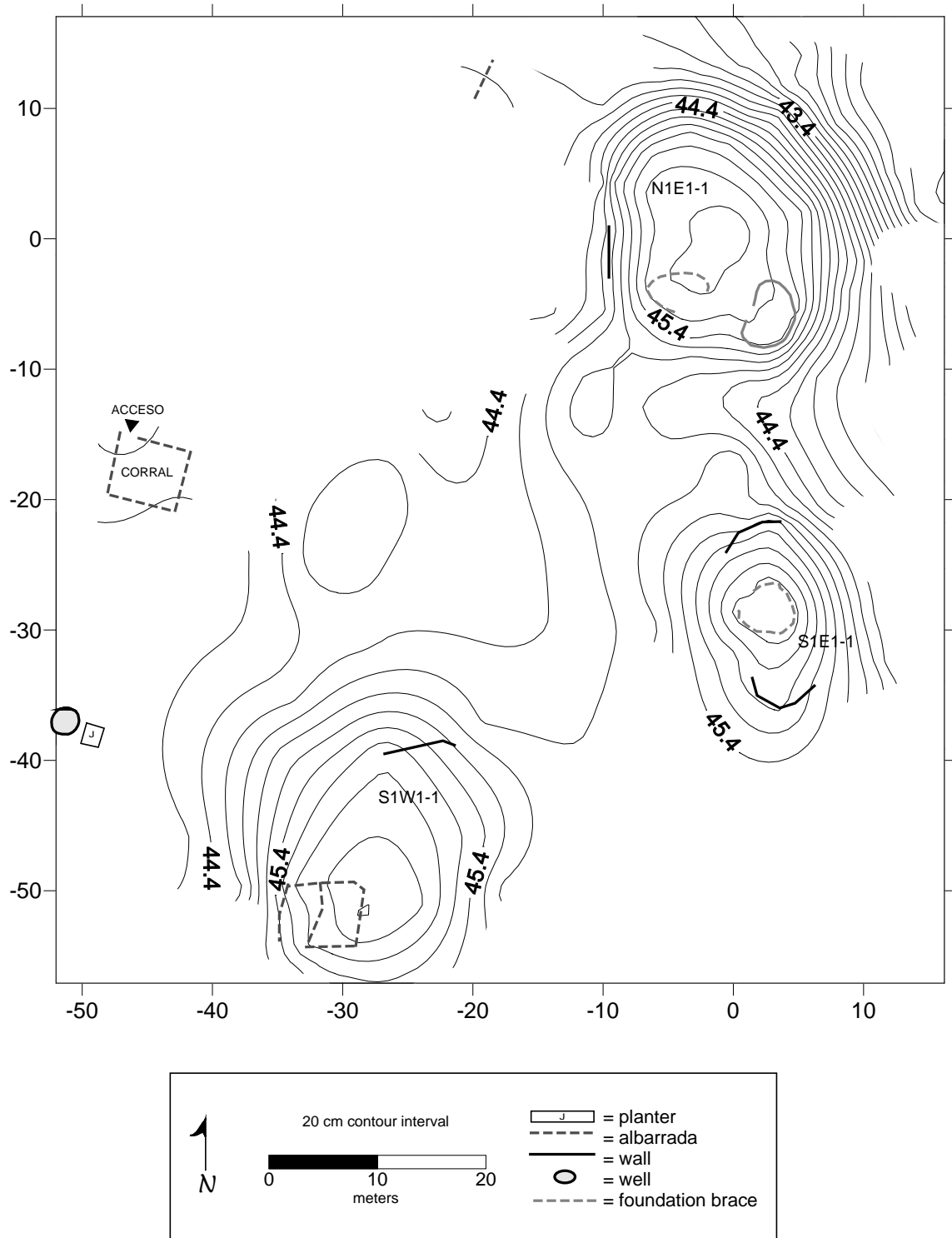

Figure 56. The Site of Rancho San Juan



Figure 57. Cut Stones on the Northeast Side of Structure S1E1-1



Figure 58. Top of Structure S1E1-1

Probably, the corral was used for poultry, since its height is similar to the modern poultry pens currently used by inhabitants of the region. The roof was likely made of perishable materials that were affected by weathering.

Part 3: The *Ejido* of Sacalaca

Chapter 21: The Site of Rancho Santa Elena

Jorge Pablo Huerta R. and Johan Normark

Rancho Santa Elena is located about 5 km north of the modern town of Sacalaca. It has been visited in previous field seasons; the most recent occurred in 2008. This site has been inhabited for about the past 32 years, being the unique Prehispanic-Historical settlement in the region with permanent occupation at present. It is unlike the majority of the other sites currently being utilized in our study area, which are visited and used only as workstations for local farmers. This occupation has modified the environment with the presence of roads (for cars), rooms and infrastructure of the contemporary farmers (e.g. granary, corrals, and toilets, among other things).

Prehispanic remains (Figure 59) include Structures N1E1-1, S1E1-1 and S1E1-2, which are located southeast of the current entrance to the ranch (200 m), amid dense secondary vegetation. Structure N1E1-1 (about 30 x 20 m) seems to have two stepped bodies; its façade points to the north. Although we can see several of its architectural elements, such as corners and walls, it appears that the structure lies directly on bedrock, taking advantage of a natural outcrop. Near the center of this building, on the north side, two balustrades were located. These define a space of about 4 m that should correspond to the width of the steps, but only one of these is visible. It was impossible to identify the southern wall of the base of the structure, due to its advanced deterioration and the existence of a looter's hole. The highest layer of this stepped structure has the same orientation as the inferior level and still shows some remnants of its walls. The balustrade of the north wall continues until the second level, but is not complete, due the existence of another looter's hole. South of this, there is a *pila* and a jamb stone. In addition, we also found some façade elements that resemble a Puuc style (see Huerta 2008: 146-152). Atop the structure, it is possible to observe the vestiges of a Postclassic shrine, as well as some other alignments and two looter's holes.

About 23 m south of Structure N1E1-1, Structure S1E1-1 is located. It is a rectangular platform measuring about 11 x 24 m. Around one corner, are two *pilas* or *metates*, one complete and one incomplete.

South of this structure is Structure S1E1-2, also a rectangular platform similar to Structure S1E1-1. Additionally, Structure N2W1-1 is located about 52 m southeast of the former school of this village in a nearby area that is a sort of courtyard, where current residents carry out numerous activities. Some walls and corners of this structure are still visible. Atop of this structure, two "C"-shape foundation braces were located. About 58 m northwest, the pyramidal Structure N2W1-2 was found; it is about

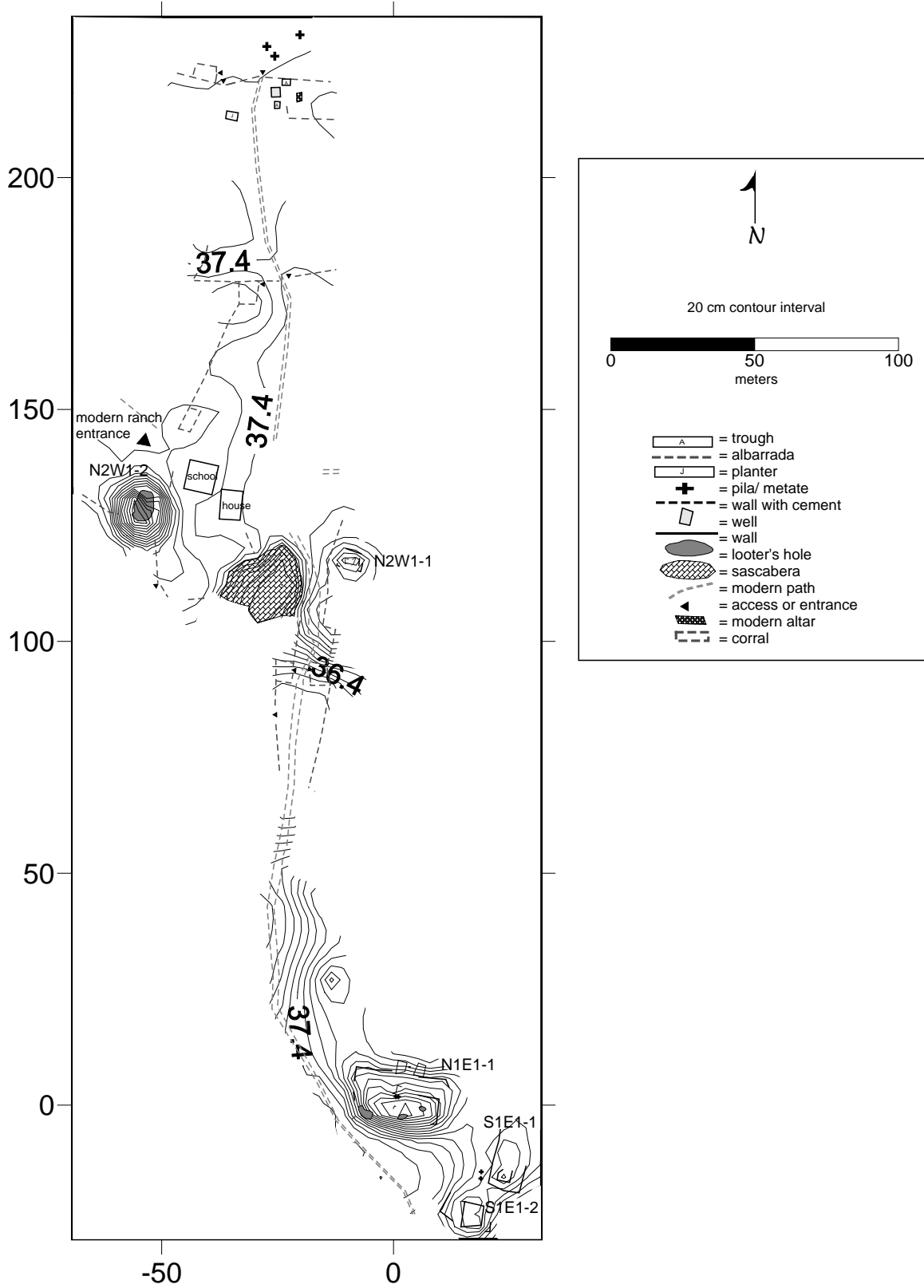

Figure 59. The Site of Rancho Santa Elena

2.5 m high. Unfortunately, this building is located in an area where many human activities are carried out; thus, its condition is very poor. There is a looter's hole atop the structure, while on its lower part the remains of several *albarradas* are still visible. Alignments of the remains of this building correspond to Structure N2W1-1.

Historical remains of the settlement are located mostly in the north area, and have been reused, in recent times, by the current inhabitants of the village of Santa Elena. Directly south of the access road to the ranch is a square-shaped building of recent manufacture, which functioned as an elementary school until a few years ago and currently serves as a warehouse. To the southeast is the home of the present inhabitants of the settlement. Northwest of the former school is a rectangular corral, which is currently employed for raising sheep. In the northern part of this corral, three *plias* were located.

The well is square; to the northeast and south of it are two water troughs. The one to the northeast is attached to an *albarrada* but it's in poor condition, while the other is well preserved and has a recently plaster surface.

A few meters from the well, a modern altar is located. It consists of a pile of rocks forming a rectangle, which are the base to three wooden crosses and some "X"-shaped façade elements that are diagnostic of the Puuc style, which have been taken from one of the Prehispanic structures.

This site, because of the modern village, is the one that has suffered a major disturbance because of its re-use throughout different periods and continuous human activity; thus, its contexts are quite disturbed. However, it is important in the future to carry out some test units to establish a relative date for its occupations and to gain a better understanding of the past of this settlement.

Part 3: The *Ejido* of Sacalaca

Chapter 22: The Site of Santa Cruz

Johan Normark, Pablo Huerta and Dave Johnstone

Santa Cruz is the name of a cave located 6.7 km northeast of the *cenote* in Sacalaca (Figure 60). The cave is near the trail that connects Sacalaca with Xtojil and Xbalcheil. A small hillock separates the cave from the trail. The cave entrance is rather steep and a vertical drop of roughly 3 m at the steep slope. The cave was visited in 2003 and it contains charcoal drawings and Prehispanic sherds (Normark 2003). There are no structures near the cave entrance. Apiaries are kept at the end of a side path directly north of the cave entrance.

Mounds and foundation braces of various sizes are scattered around within a radius of 3-400 m. Due to time constraints we choose to map only one platform, N2W2-1, although two foundation braces are located only a hundred m to the west of this platform. Surface collection on N2W2-1 encountered three Terminal Classic sherds and one Late Formative sherd.

The south side of the platform has a fairly well preserved wall line. Top of the platform has some exposed bedrock and hence the platform is built on a small hillock. The southwest corner of the platform has a round structure, N2W2-2, with a small rectangular structure, N2W2-3, directly to the north. The largest superstructure on the platform is located on the east side. However, the foundation braces here are less complete. The northern part of the structure stands on a low platform, N2W1-2, which is on top of the larger platform (N2W1-1).

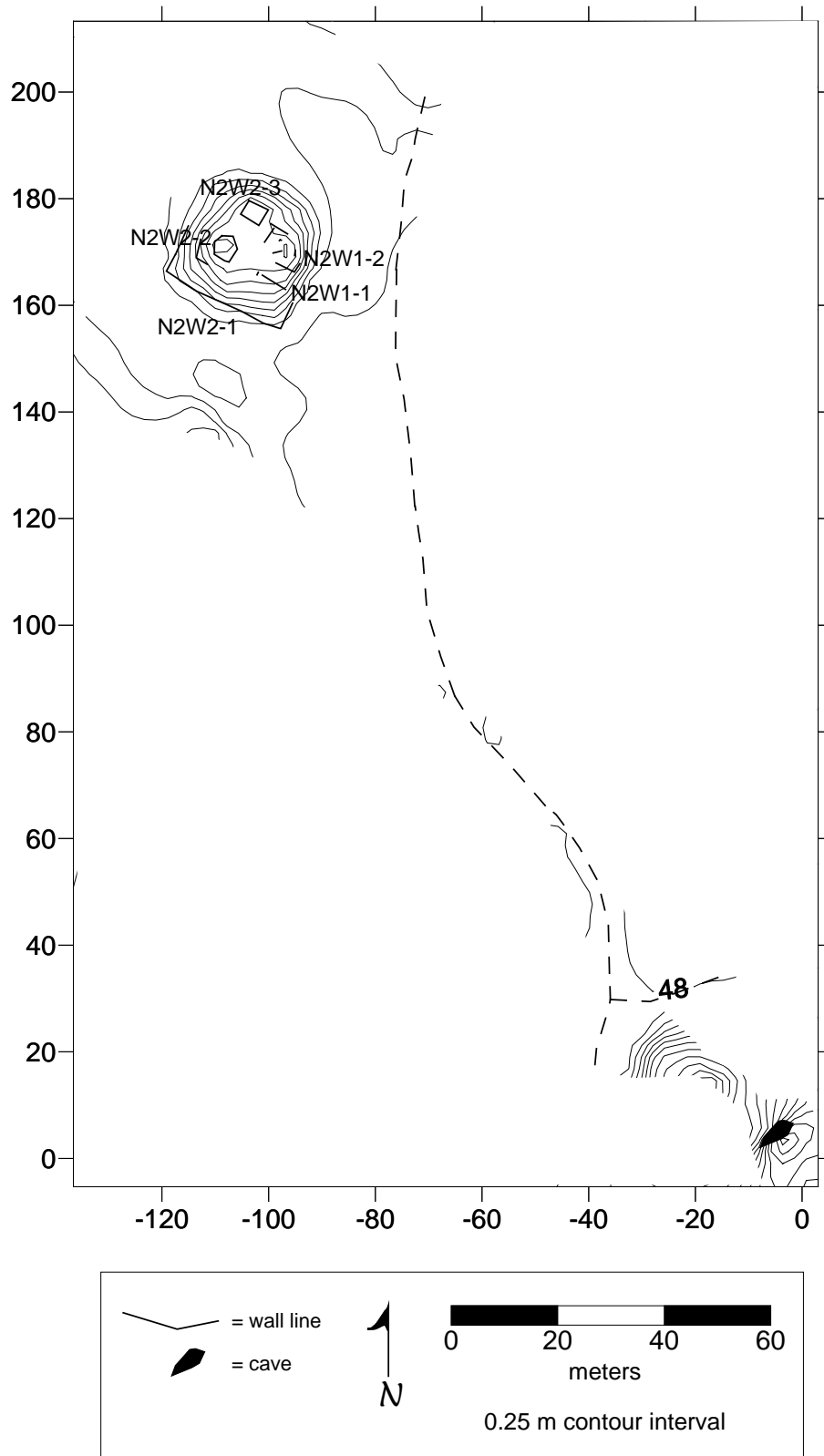

Figure 60. The Site of Santa Cruz, Sacalaca

Part 3: The *Ejido* of Sacalaca

Chapter 23: The Site of Xbalcheil

Dave Johnstone

The site of Xbalcheil is located 10 km northeast of Sacalaca (Figure 2). It was recorded by Flores (2004), and sketch mapped as well as test pitted by Keading (2005). The site consists of both a Historic and a Prehistoric component. The Historic component includes a multi-room masonry house facing a large enclosure that includes a masonry gate. Such gates have also been recorded at Xbaquil (Flores 2004, Keading 2005), Ramonal Poniente (Flores 2004), and Pancho Villa (see Chapter 8 this volume). Several Prehispanic mounds have been recorded to the south of the house.

The mapping efforts this season (Figure 61) were concentrated around the house, and while we did not encounter any new features, some additional details were noted. The first of these are two ramps on the east and south faces of the platform supporting the house. These are of a grade low enough to permit draft animals access to the platform summit. These animals may have been used in drawing the water from the well. The second detail of interest is the reuse of a set of beveled sawn stone slabs in the stairs leading to the central door of the house (see Keading 2005: Fig. 57). Identical slabs were used in the construction of *bebederos* (drinking troughs) at both Pancho Villa and at Xbaquil. Since Pancho Villa bears a pre Caste War date, it is likely that all three haciendas are contemporaneous. Flores (2004:197) notes that this time corresponded to a sugar boom in the region. The *haciendas* may then correspond to this occupation and use of the land for intensive agricultural purposes, while the smaller ranchos are later phenomena, and for a different use of the land.

Three small surface collections were made from the east, northeast, and south of the house platform. Sherds dating to the late Formative, Early Classic, and Terminal Classic periods were recovered. These samples mirror the sample recovered from Operation 1, and suggest that the platform itself may have been constructed atop a Prehispanic mound.

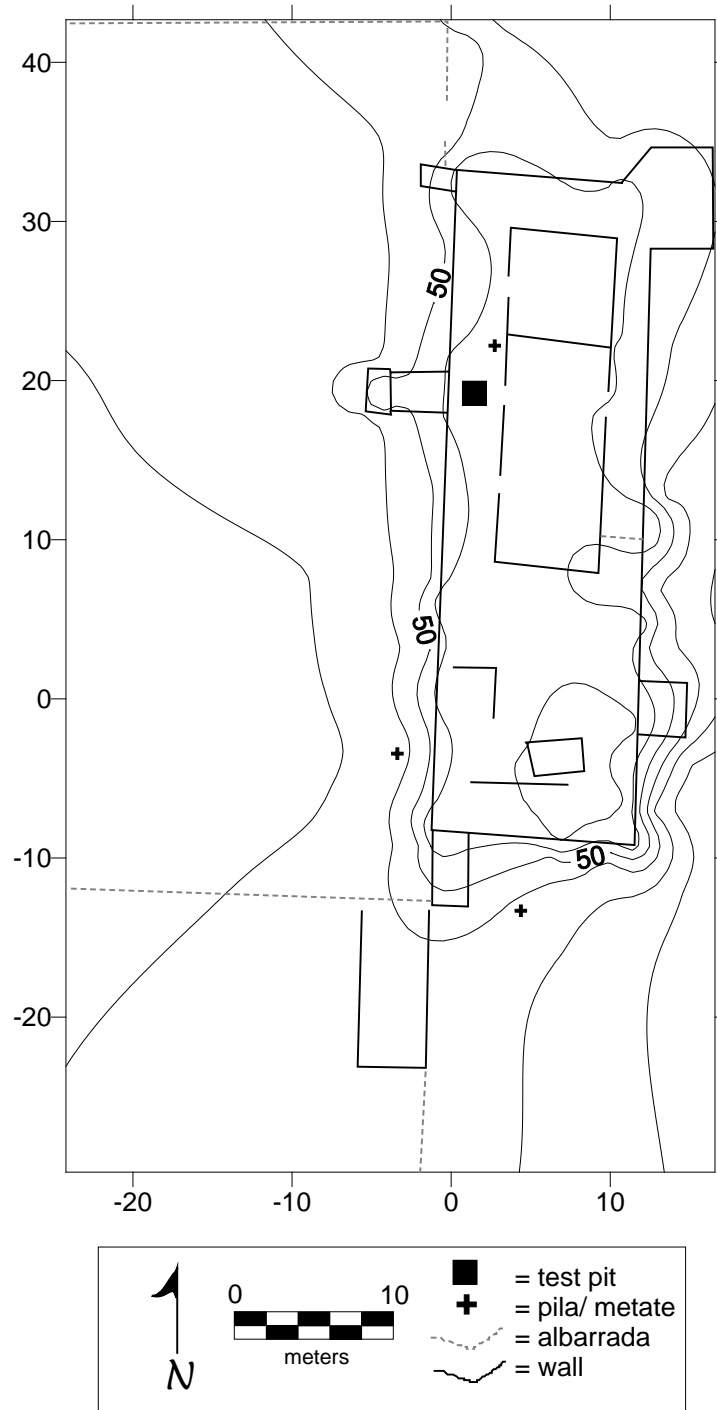

Figure 61. The Site of Xbalcheil

Part 3: The *Ejido* of Sacalaca

Chapter 24: The Site of Xtojil

Johan Normark and Dave Johnstone

The site of Xtojil (“Place of the *toj* [motmot]) is located 8.2 km northeast of the *cenote* in Sacalaca. It was first recorded by Johan Normark and Alberto Flores in 2003 and a sketch map was drawn (Normark 2003).

Mapping of the site began in a recently cleared *milpa* in the southern part of the site (Figure 62). This area was located on a higher altitude than the major architecture at the site. Here several foundation braces for perishable structures were located, a *chultun* (subterranean chamber), and some terraces. Surface collection in the area revealed mainly Terminal Classic sherds and only one Late Formative (Sierra Red) sherd.

The *milpa* contained two groups of foundation braces. The western part had four structures on the western and southern side of a hill/platform that together make up a household group called S1W1-1. Three *pilas* were found in the wall of Structure S1W1-5. Two *pilas* were found inside S1W1-3. On the eastern side of the group there is a terrace. A *chultun* is located north of the platform.

The eastern part of the *milpa* contains a second group of foundation braces, located on a slightly higher elevation. This group is called S1E1-1. The group has an inner patio and it is surrounded by structures on all sides. Two *pilas* are located in the center of the patio. The foundation braces consists of uncut boulders. Best preserved of these foundation braces is Structure S1E1-2. Structures S1E1-3 and S1E1-4 have an internal wall line that divided the structures into two rooms. Structure S1E1-6, which is located in the northern part of the group, also has an internal wall with rough uncut stones. This structure faces the patio with its southern short end. The structure appears to have been constructed on top of an earlier structure with a wall of well cut stones. This wall is located directly south of the later structure.

North of the *milpa* area, and at a lower elevation, is a plaza group with several low structures. The southern side of the plaza has three structures. Structure N1W1-1 is a platform that supports a foundation brace and a possible Postclassic shrine. Directly east of the platform is a short alignment of stones that runs parallel with the trail. Structure N1E1-3 is a small platform that is located closer to the center of the plaza than the other surrounding platforms. Structure N1E1-2 is located in the southeast corner of the plaza group. This platform has large uncut boulders and partly exposed bedrock.

In the southern part of the eastern side of the plaza we find Structure N1E1-1 which is a small mound supporting a Postclassic shrine. A short foundation brace runs to the northeast. Parallel with this foundation brace is a longer *albarrada*. The *albarrada* closes off the eastern side of the plaza group from a low drop in elevation. The *albarrada* ends in the southern side of Structure N1E1-8 which is a low mound. Structure N1E1-8 is located directly on the edge of a *sascabera*/cave opening. The entrance to the cavity is filled with debris. East of this opening is a small foundation brace, Structure N1E1-7.

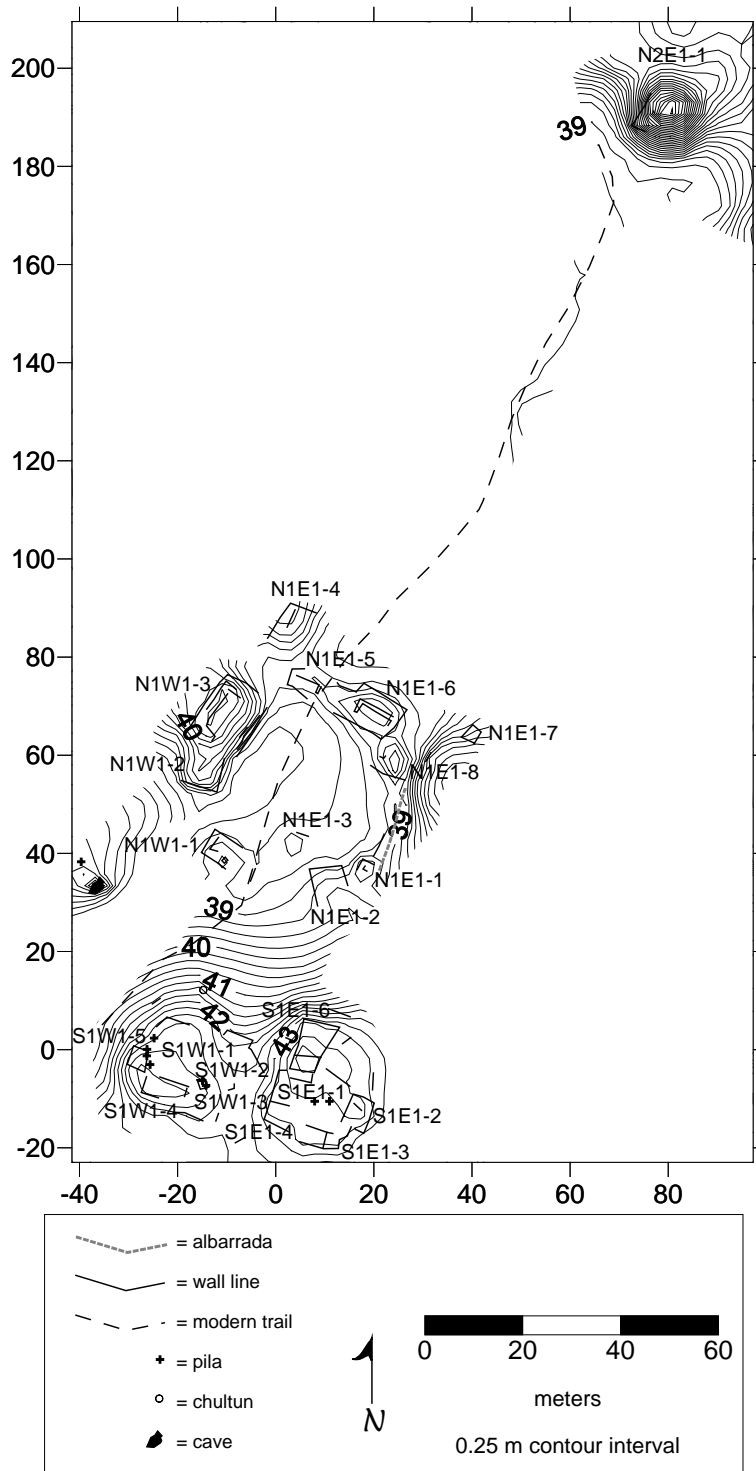

Figure 62. The Site of Xtojil

The northern part of the plaza contains some interesting structures. Structures N1E1-5 and N1E1-6 are platforms that support C-shaped structures with double walls (or rather “open fronted structures”). These are usually seen as “post-monumental” and date roughly to AD 950-1030 (late Terminal Classic). The platform of N1E1-6 is broader in the eastern section, which is the part that supports the open-fronted foundation brace. The C-shaped wall of Structure N1E1-6 is fairly well preserved. The stone of the western end of the C is still *in situ*. Structure N1E1-5 is located on a lower platform and is also less well preserved than Structure N1E1-6, which partly is explained by the nearby trail that runs parallel with the eastern part of the C. The northwest corner of the plaza is occupied by a low platform with traces of a foundation brace (N1E1-4).

The western part of the plaza is dominated by the largest structure of the plaza group, N1W1-3. Even here we have a C-shaped structure and it is larger than the other two C-shaped structures at the site. It sits on a substantial platform that even had a stairway with five steps which is unusual for these “post-monumental” structures (Figure 63). No earlier super-structures were located on this platform so it is possible that the platform was built to support the C-shaped structure. The southern part of this platform has another angle and coarser stone work and is most likely a later (maybe Postclassic) addition, Structure N1W1-2.

Directly southwest of the main structure of the plaza group is a cave which has a *pila* located near its entrance (Figure 64). The cave is said to have a pool of water, hence its name since the *motmot* bird lives near water.

In the northern part of the site there is a 7-m-high pyramidal structure, N2E1-1. Portions of the southern wall are fairly well preserved. This wall appears to be early Terminal Classic and hence it is probably older than the C-shaped structures at the site. Northeast of the pyramid is a platform that never was mapped. Directly east of the pyramid is a large *sascabera* with a column that supports the roof of the *sascabera*. West of Structure N2E1-1 are several unmapped foundation braces located on low hills



Figure 63. Stairway of Structure N1W1-3 at Xtojil



Figure 64. *Pila* Near the Entrance of Aktun (cave) Xtojil

Part 3: The *Ejido* of Sacalaca

Chapter 25: The Site of Yo'dzonot, Sacalaca

Justine M. Shaw and Alberto G. Flores C.

A small portion of the site of Yo'dzonot was recorded during the CRAS project's prior field season (Kaeding 2008). This 2010 season, the site was subjected to more detailed scrutiny and topographic maps were recorded of four of its components. These included not only the historic component of the site, but also three nearby locales with Prehispanic remains. It is likely that occupations from all periods were attracted to the area by the site's *cenote*, one of the furthest south and west in the survey area.

The area immediately around the *cenote* is a relatively small (approximately 10 sq m) depression, with access to the water table at its western edge. The *cenote* probably originally had a rather restricted opening, which was modified into a squared off well surrounded on three sides by a wall (Figure 65). Stone walls containing mortar enclose the depression to its southeast and northeast, with a *bebedero* centered on the exterior of the southeastern wall. Additional *albarradas* form corrals to the northeast of the well area.

Until a few years ago, bees were also maintained a short distance to the northwest of the well. A *palapa* immediately to the southwest of the well still houses the remains of the beekeeping supplies. Local consultants report that these bees, like some others, have left the area following several extremely dry years. The most recent modifications to the area are the amplification and formalization of the path from Sacalaca to the well. As part of an effort to promote ecotourism in the area, the path was raised slightly, paved with *sascab*, and lined with stones. Some of the nicely cut stones that line the path near the well may have been taken from features that were part of prior occupations.

In searching for Prehispanic remains that might have been associated with the *cenote*, some sherds and minor modifications were noted in a *milpa* approximately 100 m to the northeast. These surround a deeper pocket of *chac luum*, which was likely also used for farming in the past. Following a path through this field, a denser settlement concentration was noted beginning about 350 m to the north of the *cenote* (Figure 66). The modern entrance to the zone is through a gently sloping zone that leaves a deeper *chac luum* deposit for a somewhat more elevated zone with bedrock outcrops. Many of these outcrops have been modified during occupations that appear to pertain to several different time periods. The furthest, and most modified, complex of architecture in the area is currently approached by crossing two low wall lines that appear to be part of two terraces. On their western and northern edges, these are a single course of stone at ground level, while the southern and eastern edge of the innermost terrace rise to form low *albarradas* that completely enclose the Structure S1W1-1 platform.

This platform appears to take advantage of a natural outcrop that has been most heavily modified on its western half, while the eastern half, save for the enclosing wall, is difficult to define as it grades gently into the natural terrain. Atop the platform, the

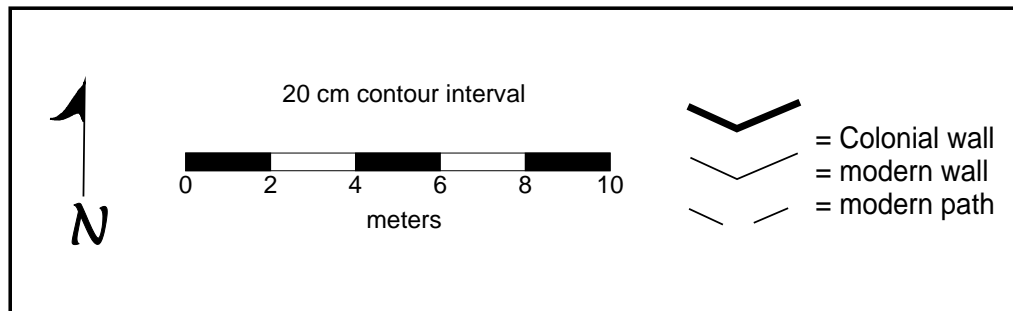
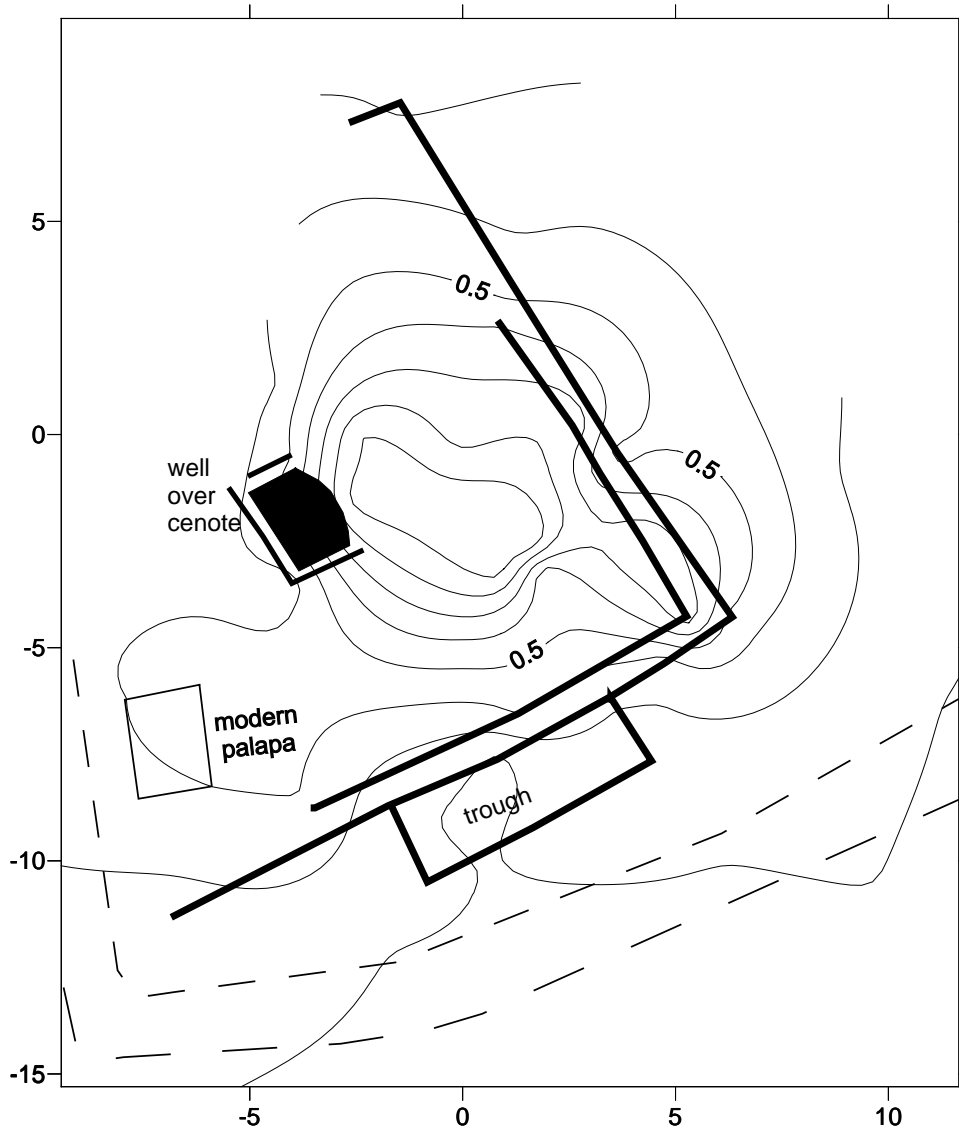

Figure 65. Yo'dzonot Well Area

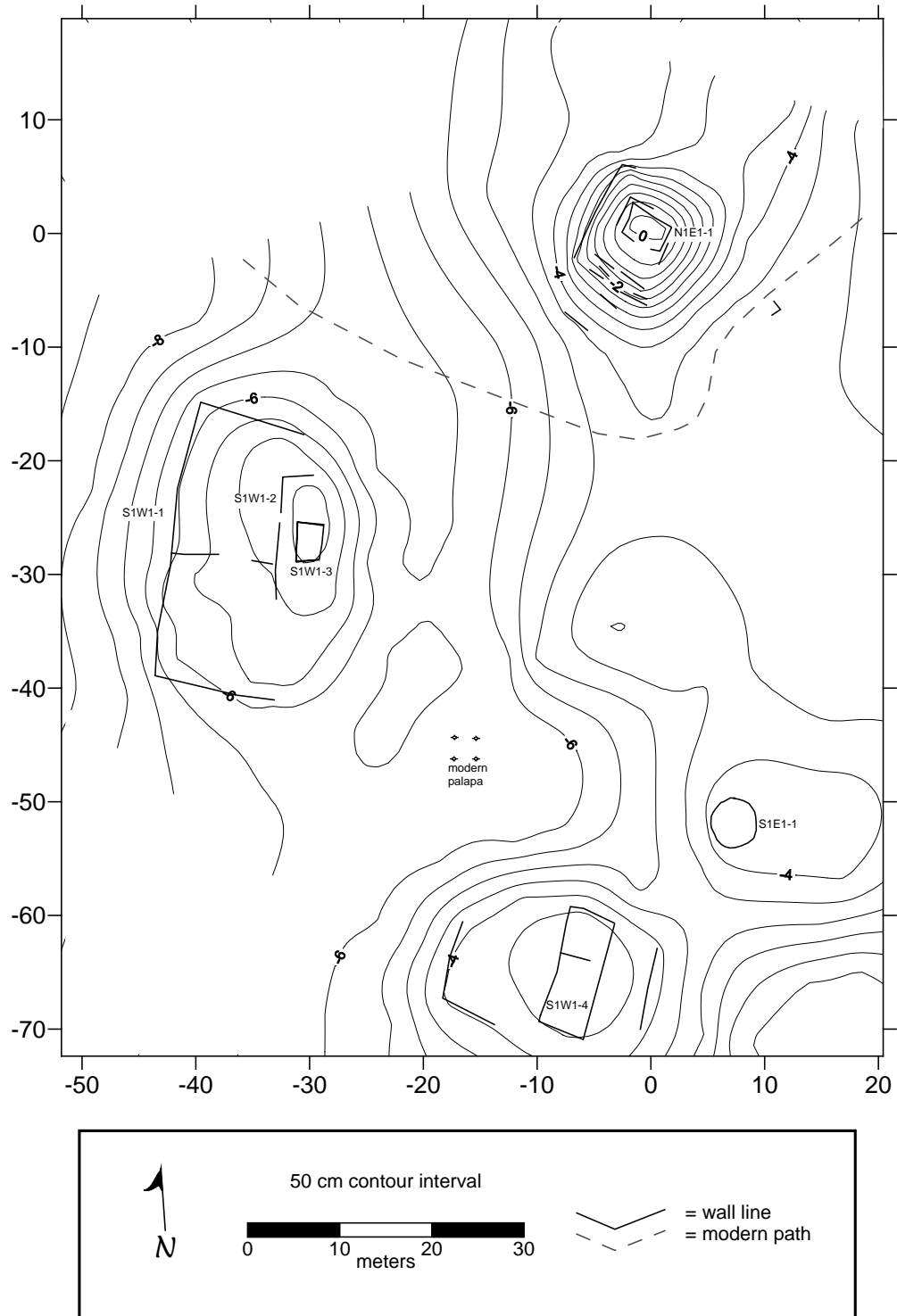

Figure 66. Yo'dzonot Milpa Area

principal structure (Structure S1W1-2) is situated on the eastern edge, with remnants of an estimated three structures elsewhere on the platform. To the north of the platform, the patio formed by the enclosing wall contains a very dense concentration of small *chich*. Based upon the presence of an extensive *sascabera* that consumes nearly the entire interior of the natural hill immediately to the northeast of the patio, it is believed that the patio may have once been either paved with *sascab* or even plastered. Although no excavation was conducted, it appears that only *chac luum* underlies the *chich*. Less densely concentrated *chich* is visible in the plaza area formed by two bedrock outcrops immediately to the northwest of the enclosed platform. Viewed from atop one of these hillocks, there is a clear point at which this enhancement ended and only pure *chac luum* is present.

The southernmost outcrop adjacent to this plaza contains the remains of at least three structures. One of these, Structure S1E1-1, is a round foundation brace of the type that Johnstone (see Chapter 48 this volume) believes may date to the Postclassic. Two similar round structures were present within this zone. Although its construction required less modification than the lower platform complex, the most extensive foundation brace at the site is Structure S1W1-4, which also commanded the best view of the surrounding territory. It appears that stones are missing from its center, likely reused in the adjacent round structure; this is consistent with a late date for the round structures here and at other sites in the survey area (Shaw and Flores 2008).

Guided by a local consultant, Flores located another architectural complex in a *milpa* in the vicinity of the *cenote* (Figure 67). Based upon its greater size, as well as the lack of other significant architecture in the area, this may have been the core of the dispersed settlement zone currently referred to as Yo'dzonot. The dominant feature in the area, Structure N1E1-1, is a 4-m mound that sits atop a natural bedrock outcrop. Several of its components remain intact, including a western wall line that indicates that the mound may have once been composed of several stepped terraces; portions of a southwest-facing stairway are also visible. The remains of a Postclassic shrine are visible to its east and Structure S1E1-1, a round foundation brace, likely also dates to this later time period. Structure S1W1-4 sits atop a platform leveling another natural bedrock rise and wall lines atop the platform Structure S1W1-1 attest to a series of sequential occupations in the area, including Structure S1W1-3, which appears to be a Postclassic temple.

Nearby, another cluster of architecture was located in a more overgrown zone (Figure 68). Here, two platforms built atop bedrock outcrops were recorded, with more wall lines and features visible in the adjacent dense underbrush. While its northern edge is more irregular, utilizing available bedrock, Structure N1W1-1's southern face includes more significant investment. In some places, four courses of large, shaped stones remain intact (Figure 69). An unusual building, Structure N1W1-3, is perched upon this northern edge. It appears to have contained two rooms, currently visible as elevated collapse, separated by a depression. The outer wall lines of the foundation brace continue through this lower area. It may have been an open passage or small patio to access the two rooms, perhaps with a perishable roof. Structure N1E1-1 juts out of the eastern side of the platform. While its platform edges are well-defined with large stones, it is likely that the irregular shape owes its form to

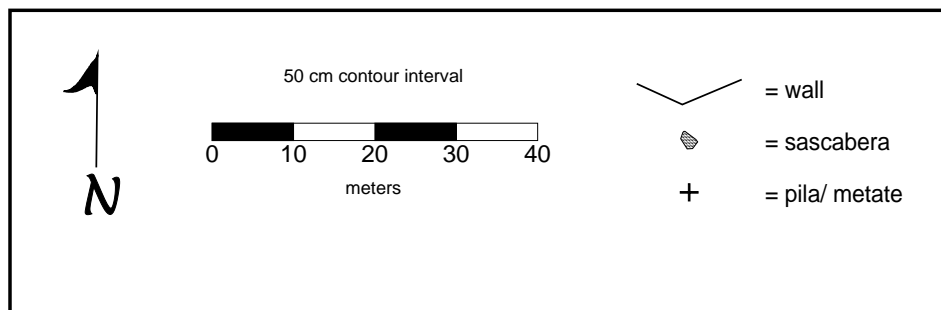
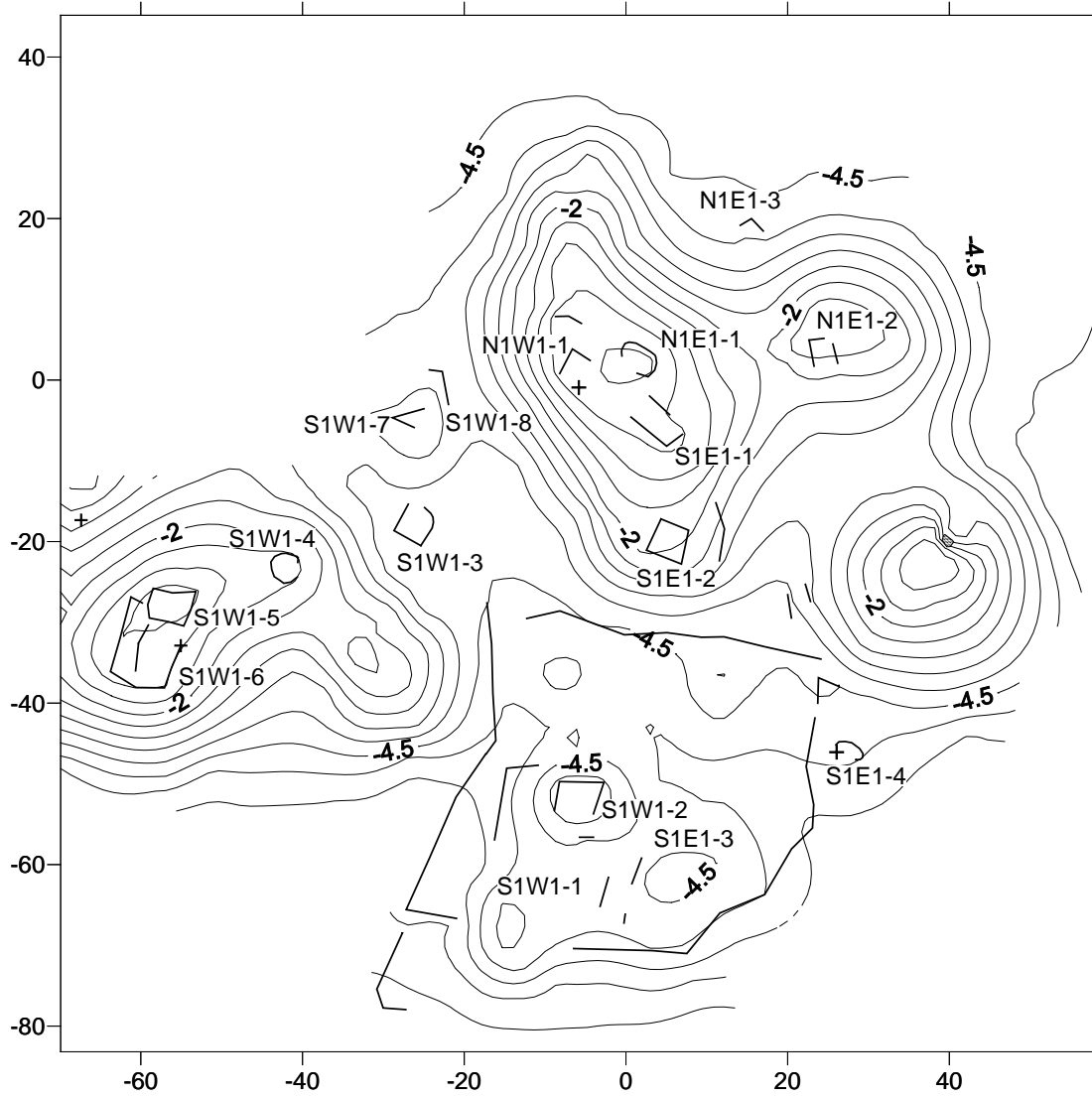

Figure 67. Settlement Zone, North of Cenote Yo'dzonot

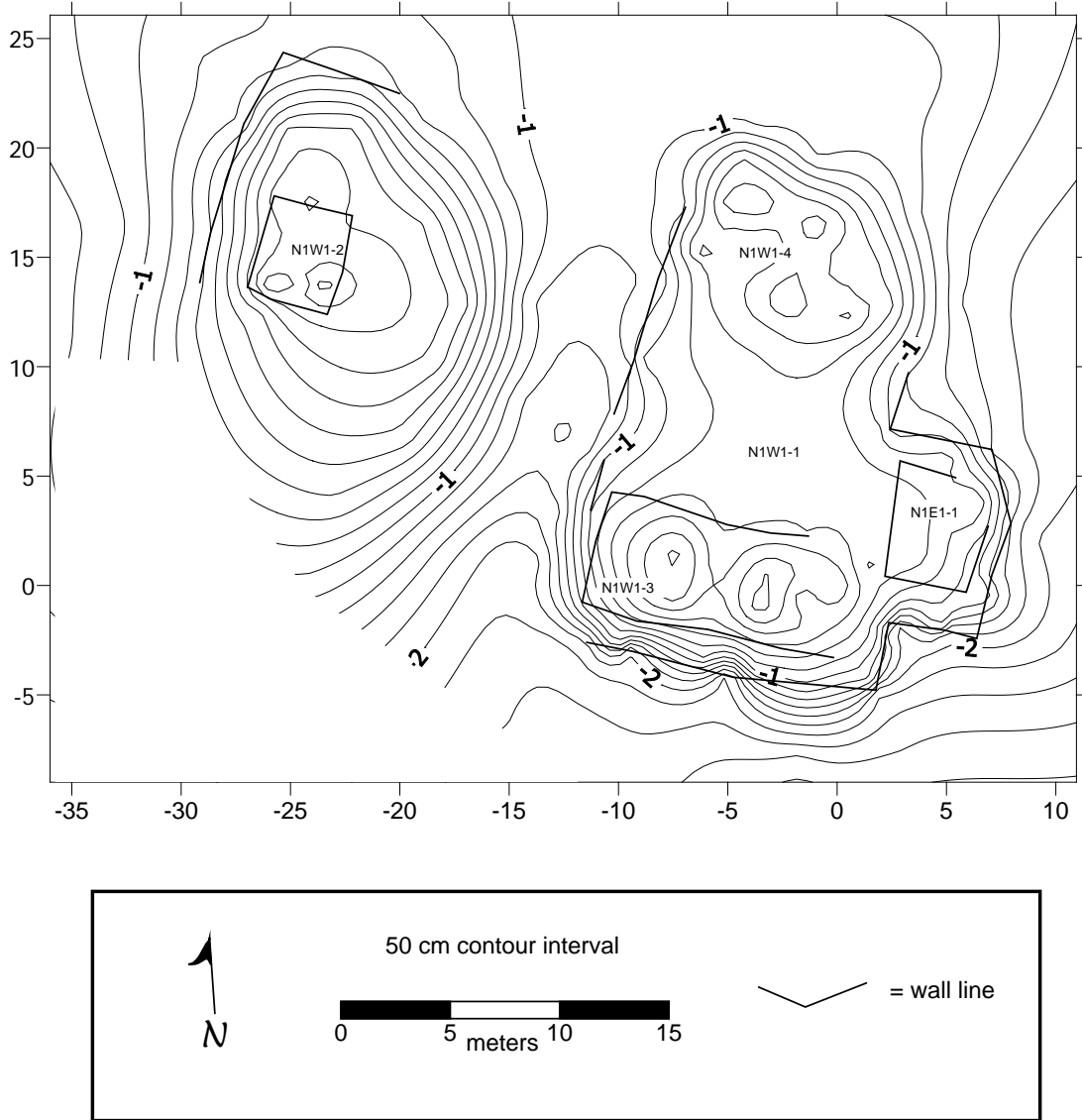

Figure 68. Platforms at Yo'dzonot

that of the underlying bedrock. Structure N1W1-4 lacks visible intact wall lines, although its collapsed form indicates that it once was composed of four contiguous rooms. Just a few meters to the west, Structure N1W1-2 graces a less modified bedrock outcrop.

As with other sites in the survey area, these architectural arrangements, along with other remains yet to be documented, demonstrate a nearly continuous, relatively low density settlement pattern. Modern place names have been utilized to define some of the clusters as distinct sites, as they appear on the map of the CRAS survey area (Figure 2). However, this is somewhat misleading, as it implies both that the architecture is more clustered than it actually is, as well as that the zones between the “sites” were devoid of population. The dispersed “site” of Yo’dzonot is typical of the pattern that is found when time is taken to search away from the major nodes of architectural remains currently recognized by local consultants and project members as sites.



Figure 69. South Side of Yo'dzonot's Structure N1W1-1

Part 4: The *Ejido* of San Felipe

Chapter 26: Hopemul, Operation 1

Justine M. Shaw

One 2x2-m test pit was excavated at the site of Hopemul in 2010 (Figure 70). It provided the first ceramic sample with which to date the site, as well as to date the unique architectural style present here and at Ramonal Quemado. The architecture, which lacks cut stones, cobbles, and intact wall lines, was first documented in 2008 (Shaw and Flores 2008a and 2008b).

Operation 1 was positioned in the southern end of the ballcourt, between Structures N1W1-4 and N1E1-1. It included a stone visible on the surface whose position implied that it might have been a ballcourt marker. Operation 1, Level 1, Lot 1 began with a very dark brown (7.5YR 2.5/3) organic sediment containing many rootlets from adjacent trees, as well as numerous pebbles and cobbles (Figure 71). In addition to the possible ballcourt marker, which proved to be an uncut stone, several other uncut stones were uncovered, with their bases 10-15 cm below the modern surface level (Figure 72). All were likely collapse from the nearby ballcourt structures. Ceramics from the lot included materials from the Middle Formative, Late Formative, and Terminal Classic.

At a depth of approximately 20 cm below the surface, the sediment changed to a dark reddish brown *chac luum* (5YR 3/4), containing many more cobbles. The top of this deposit was likely the original playing surface; no plaster of any kind was discovered. Operation 1, Level 2, Lot 1 was initiated at the start of the reddish sediment. After about 10 cm of sediment and cobbles, much larger uncut stones were revealed, typical of a plaza subfloor sequence. Under these, the deposit graded to a more pure *chac luum* (dark red 2.5YR 3/6) that covered the uneven natural bedrock surface, which appeared at a depth of 45 to 101 cm below the surface. Ceramically, the second level dated to the Middle and Late Formative periods.

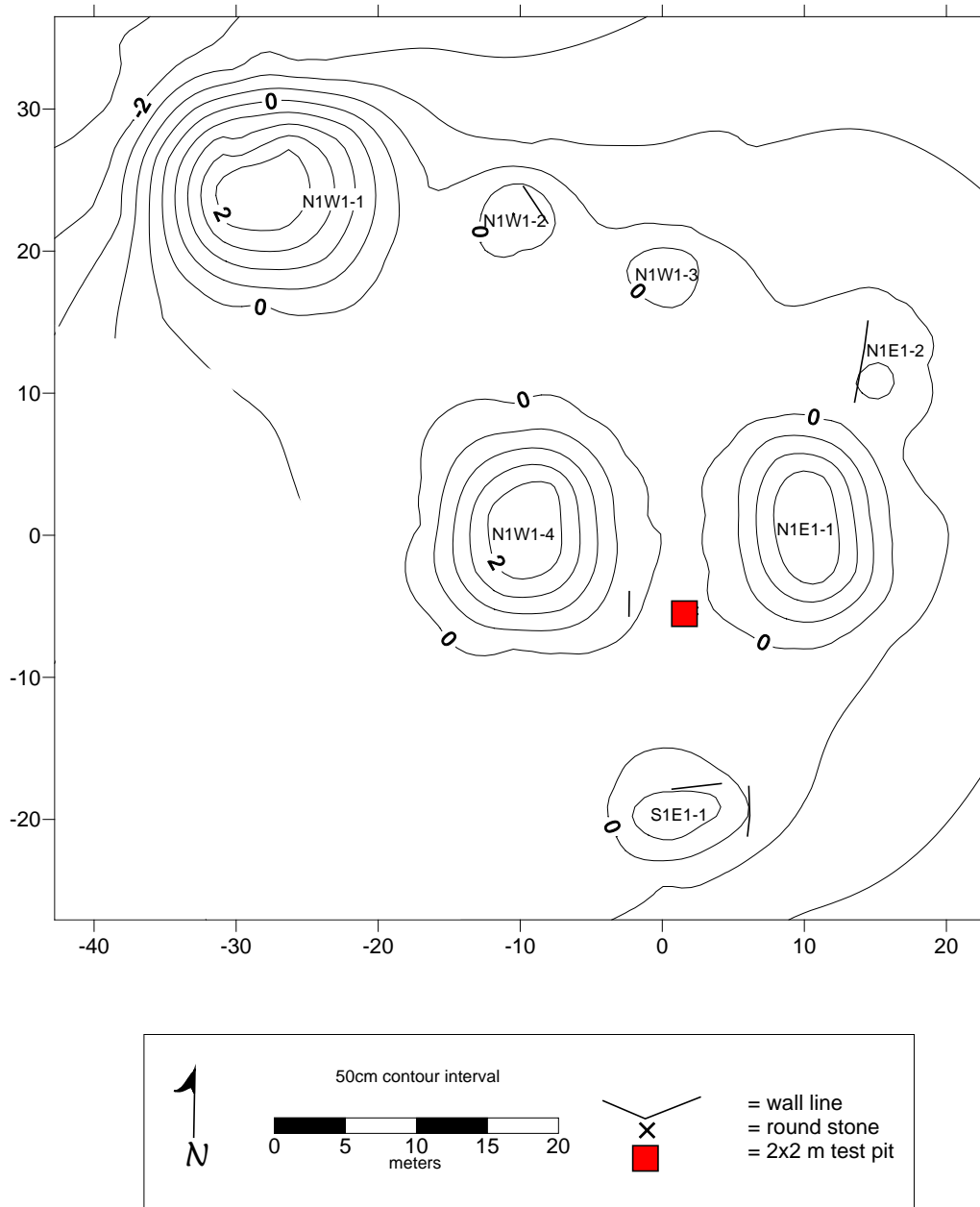

Figure 70. Hopemul, Location of Operation 1

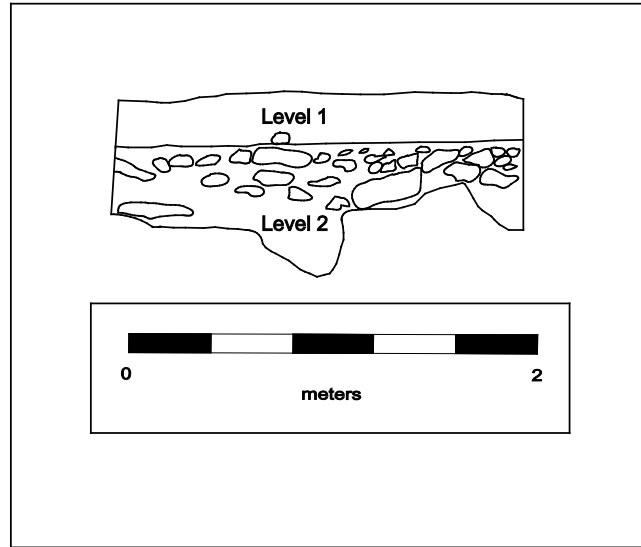

Figure 71. Hopemul, Operation 1, North Profile

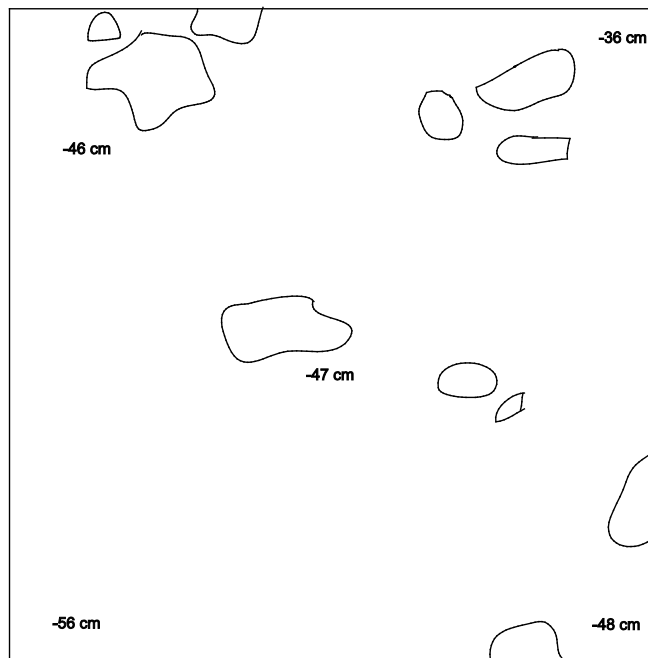

Figure 72. Hopemul, Operation 1, Initial Collapse

Part 4: The *Ejido* of San Felipe

Chapter 27: Ramonal Quemado, Operation 1

Alberto G. Flores Colin

Ramonal Quemado was documented by members of the CRAS Project in 2008, when the basic surveying and registration of the settlement and surrounding area was conducted. This season's goals for the site were to gain a preliminary understanding of the possible dates of the occupational phases, as well as any cultural affiliations of the occupants of this site. With these aims in mind, five 2 x 2-m test pits were proposed (see Chapters 26-29 this volume) for various areas of the settlement that were considered to be potentially relevant.

Operation 1 was located on the Plaza A of this site (Figure 73), opposite to Structure N1W1-2, a range structure of about 7 m in height. Plaza A is a small space raised about 1.5 meters above the surrounding terrain. Its southern side is defined by Structure N1W1-1, the northern side by Structure N1W1-2, and the eastern by Structure N1E1-1. Several structures were also found in the center of the space: Structures N1W1-5, a foundation base, as well as Structures N1W1-6, N1W1-7, and N1W1-8, which seems to have been three Postclassic shrines.

Level 1, Lot 1 of this unit consisted of a layer that was blackish in color (7.5 YR 5/1), mixed with a few pebbles and sherds. Although we found a very generous sample of Muna Slate sherds dating to the Terminal Classic, a few samples of Postclassic Chen Mul Modeled ceramics date this layer. This level was 20 cm deep on average; after its removal, we found a layer of medium-sized stones (about 20 x 20 cm on average positioned at the same depth, which makes us think that was part of a pavement (Figure 74), perhaps the base of plaza surface. Thus, it was decided to change to Level 2, Lot 1. Generally, this type of rough, cobble is used as a base for a plaster floor, which may have existed above the stones, perhaps as the last occupational surface of the plaza. Below this deposit of stones, a brown (7.5 YR 4/4) stratum was located, mixed with small, randomly distributed stones (Level 3, Lot 1). In this layer, ceramic samples dating to the Middle and Late Formative were found, as well as a single Muna Slate sherd. Once this level was removed, another set of medium-to-large stones were found, positioned at the same depth (Level 4, Lot 1). The removal of this layer revealed that these stones were part of a great, artificial leveling, composed of thick dry core fill (about 1.20 m). Stones within this level were of various sizes, arranged from largest to smallest, from the bottom to the surface. No sherds were located in this level,

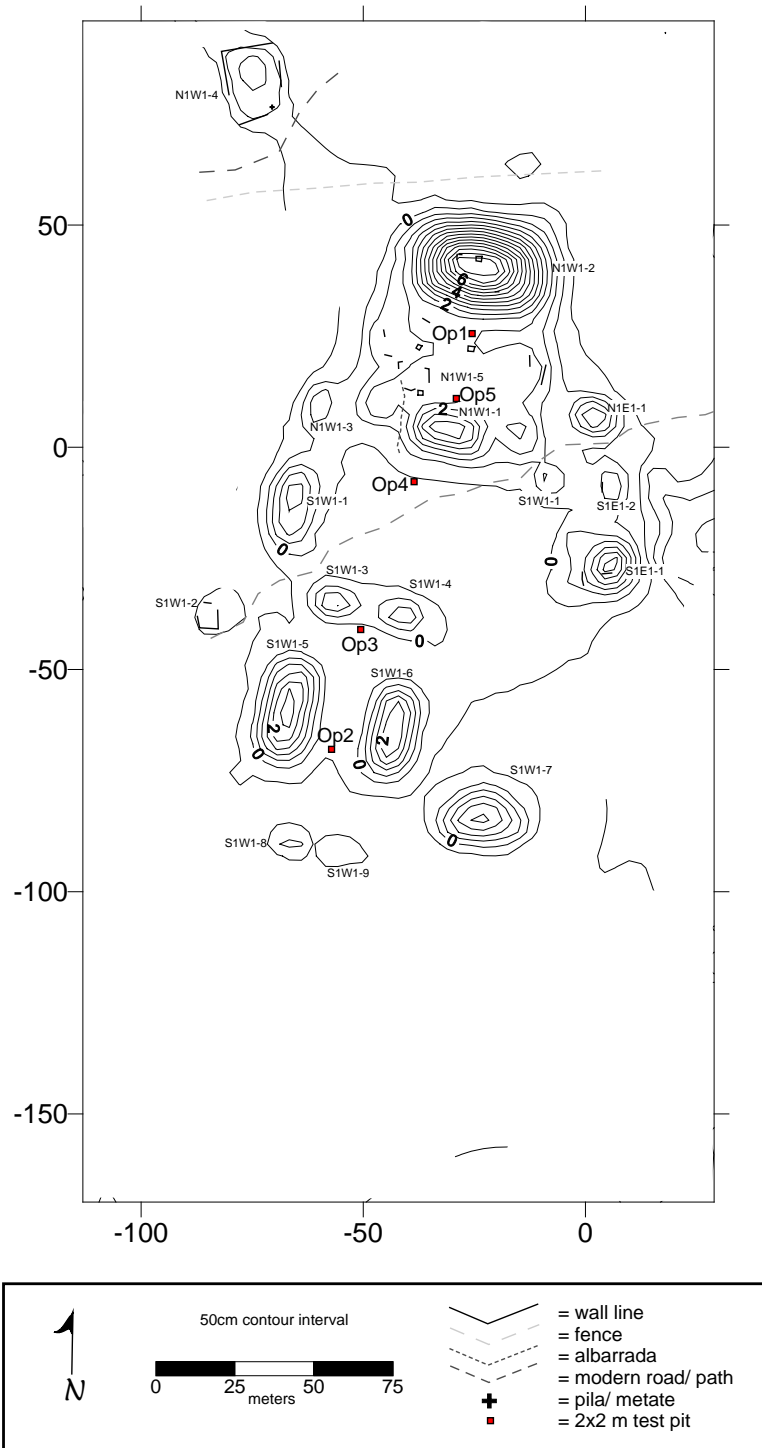

Figure 73. Ramonal Quemado, Location of Excavations

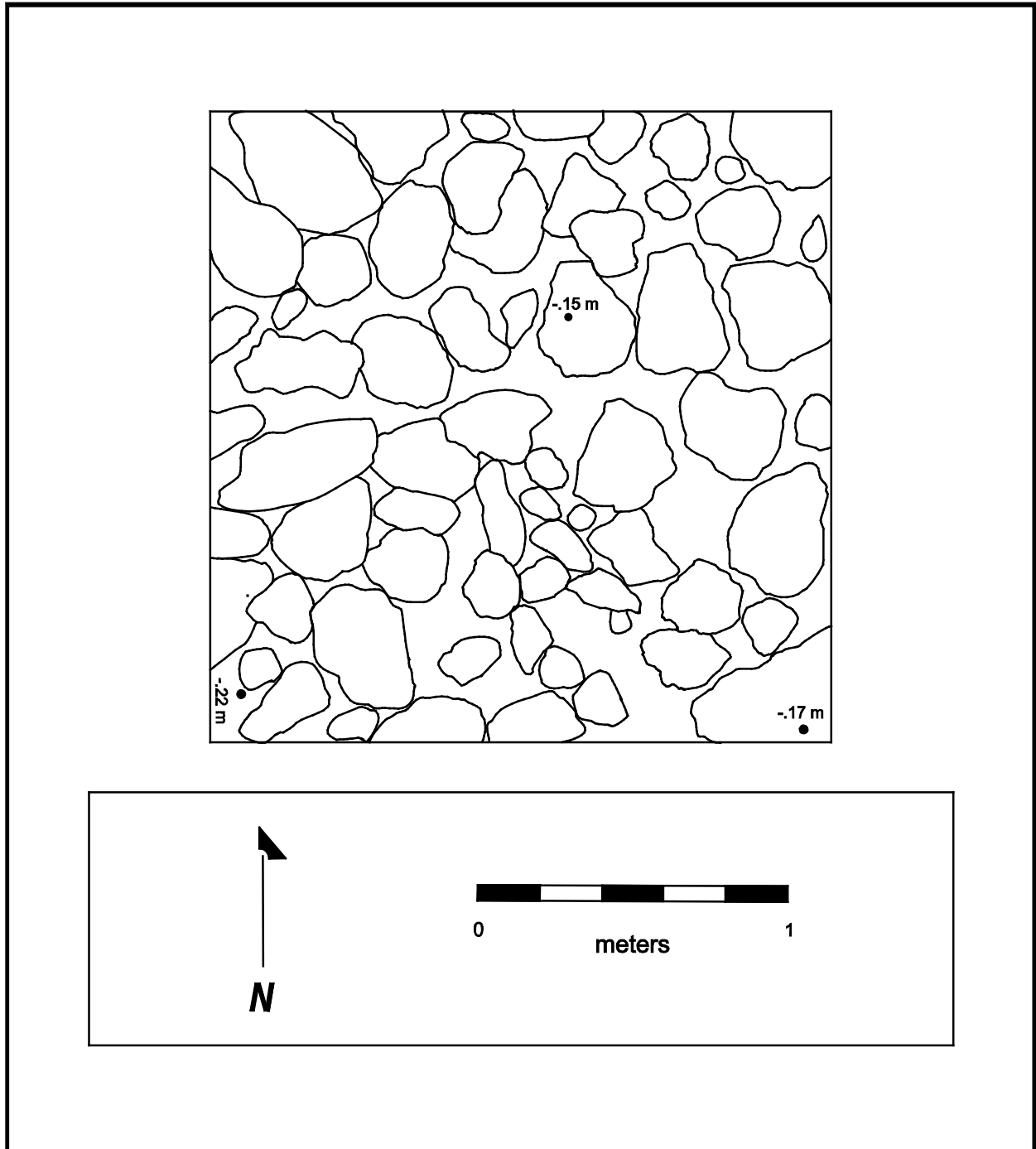

Figure 74. Ramonal Quemado, Operation 1, Level 2, Lot 1

as this construction fill consisted only of stones. Once this layer was entirely removed, a red soil or *chac luum* (2.5 YR 5/6) deposit was discovered (Level 5, Lot 1). Although no sherds were located at this level, samples found in Operation 5 (see Chapter 31 this volume) allow us to relate this stratum to the Terminal Classic, evidenced by Saban Unslipped and Lucha Incised ceramic types. With the extraction of this level, bedrock was located across the whole unit, marking the end of the excavation (Figure 75). After the appropriate recording through photographs and drawings, the unit was backfilled to the original surface level prior to our intervention.

Interpretation

Level 5, Lot 1, the red soil deposit, perhaps corresponds to the first occupation of the site, being the natural surface that was found by the first settlers to this site. In this layer, there was no construction in the space where the test pit was located, but possibly there was a platform or perishable structure nearby. Although we are indirectly dating this layer, based on Operation 5, we can assume that this deposit corresponded to the Early Classic period. Later, at some point in the Terminal Classic, it was decided to raise the level of the surface to create a raised plaza to distinguish this space from the rest of the settlement. This delimited space is what we now call Plaza A, which is shaped by the tallest structures in the settlement. This plaza was built in a single phase, using dry core fill (Level 4) and thus saving a large amount of material that would have served as a binder, making this process of construction, perhaps, faster and less costly, both in resources and construction efforts; this entire process may have been to commemorate a particular event occurred during this period.

Unlike other sites (such as Sisal, about 2 km east), the final level of the plaza was not the result of a series of plaster floors with their respective re-paving episodes, accumulated over long periods, indicating a continuous occupation. This plaza, the highest of the site, was built as a single phase suggesting that its creation was due to a change in the occupational history of the site, which would explain the radical change in the use of this space, rather than a continuous process of gradual additions through time. The surface of this plaza, elevated during the Terminal Classic, must have existed at some point during the Level 3, Lot 1, and perhaps was a plaster floor. Usually, dry core fill is the base for the plaster floor of a plaza surface. After this perhaps plastered surface, at some point, also during Terminal Classic, a new leveling of the plaza, of about 30 cm above the previous level, was conducted. It reached the top of a new subfloor (Level 2, Lot 1), which may have been the base for a second and final plastered floor or plaza surface, which must have existed as part of Level 1 and is now eroded and mixed with the organic stratum. Due the relative distance from Structure N1W1-2, there was not much material from the structure's collapse in the area where Operation 1 was positioned. This last surface belongs to the Terminal Classic, probably

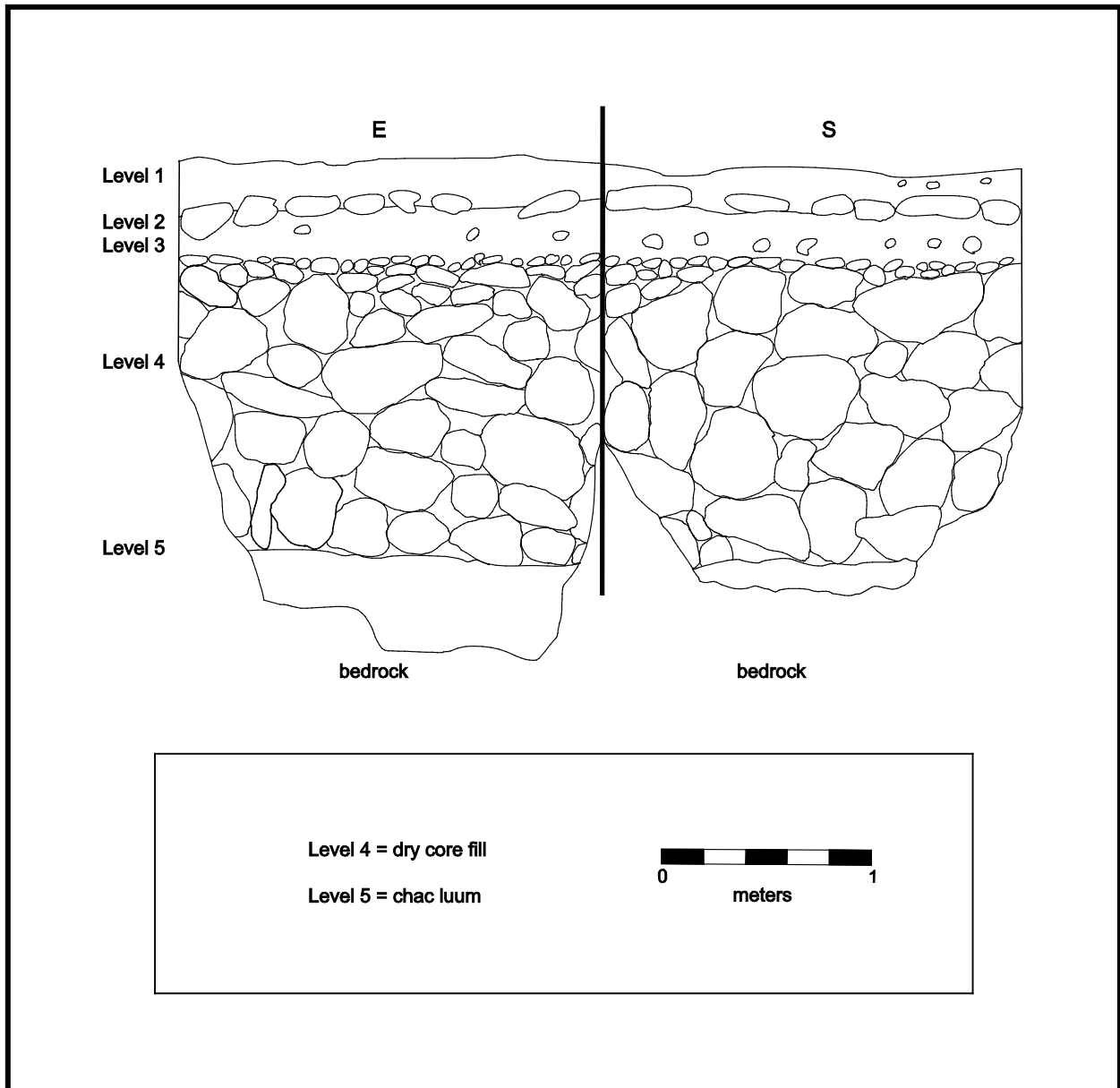

Figure 75. Ramonal Quemado, Operation 1, East and South Profiles

abandoned and reused by the inhabitants of the Postclassic, who built the perishable structure and the three shrines that crown the square. Although excavations in this area of the site are not conclusive, they do allow us to hypothesize that the construction of this part of Ramonal Quemado was motivated by a specific purpose at a particular time (during the Terminal Classic), perhaps a commemorative event or an alliance. Future excavations and surveys at this site will help us to get a better understanding of these processes.

Part 4: The *Ejido* of San Felipe

Chapter 28: Ramonal Quemado, Operation 2

Alberto G. Flores Colin

Ramonal Quemado was documented by the CRAS Project in 2008, when the basic documentation, topography and survey, was conducted. According to the main goals of this season, and continuing with the task of the basic recording of the site, it was decided to place a test unit in what we assume was the playing field of a ball court, comprised of Structures S1W1-3, S1W1-4, S1W1-5, S1W1-6, S1W1-8, and S1W1-9. This ball court complex is about 50 m long; Operation 2 was located near the center of this space, closer to the Structure S1W1-5, one of the lateral platforms (Figure 73).

Within Operation 2, three stratigraphic levels were revealed. Level 1, Lot 1 consisted of a layer of humus or organic material, mixed with a very clayey red soil (2.5 YR 5/6) locally known as *chac luum* (literally "red soil" in Yucatec) and a few pebbles (about 7 x 5 cm on average). This level was about 20 cm thick and was completed with the appearance of a layer of red soil (2.5 YR 5/5) with a claylike consistency. This new deposit was designated as Level 2, Lot 1, which also had several medium-sized stones, of about 20 x 30 cm on average. The thickness of this level was about 15 cm. It ended with the discovery of a layer of stones or cobbles that covered the entire unit (Figure 76), although the stones were lying slightly apart from each other in a matrix of red soil or *chac luum* (2.5 YR 4 / 6). Once this pavement (Level 3, Lot 1) was removed, after its proper recording, this layer was excavated until bedrock was found, after about 20 cm. Bedrock was not a level surface, but was lower in the southeast portion of the unit (Figure 77). Once Level 3, Lot 1 was removed, and after the corresponding recording, the unit was backfilled to its original level. It is noteworthy that in the whole unit a single sherd was found, which could not be identified because of its poor condition, thus this test pit could not be dated directly.

Interpretation

As has been mentioned, the lack of sherds did not allow us to date this unit directly. However, we can make some analogies based on data from Operation 3, which was also located within the area of the playing field of the ballcourt (in the north area), close to the Structures S1W1-3 and S1W1-4 (see Chapter 29 this volume). According to data from Operation 3, Operation 2, Level 3, Lot 1 may correspond to the Late Formative period, primarily evidenced by a large sample of Sierra Red ceramics. This comparison can be done since this is a red soil layer, on top of the bedrock and below the surface of the playing field of the ballcourt; a similar layer of red soil was located in Operation 2 at same level. If these are the same deposit, it is likely that at that time the site was only inhabited by groups that did not carry out significant constructions in this space, possibly by people that solely made perishable structures or other more ephemeral constructions. It was probably at the time of the creation of a formal plaza and other buildings that comprise the site of Ramonal Quemado that this ballcourt was constructed, with a surface that was covered by a layer of medium-sized

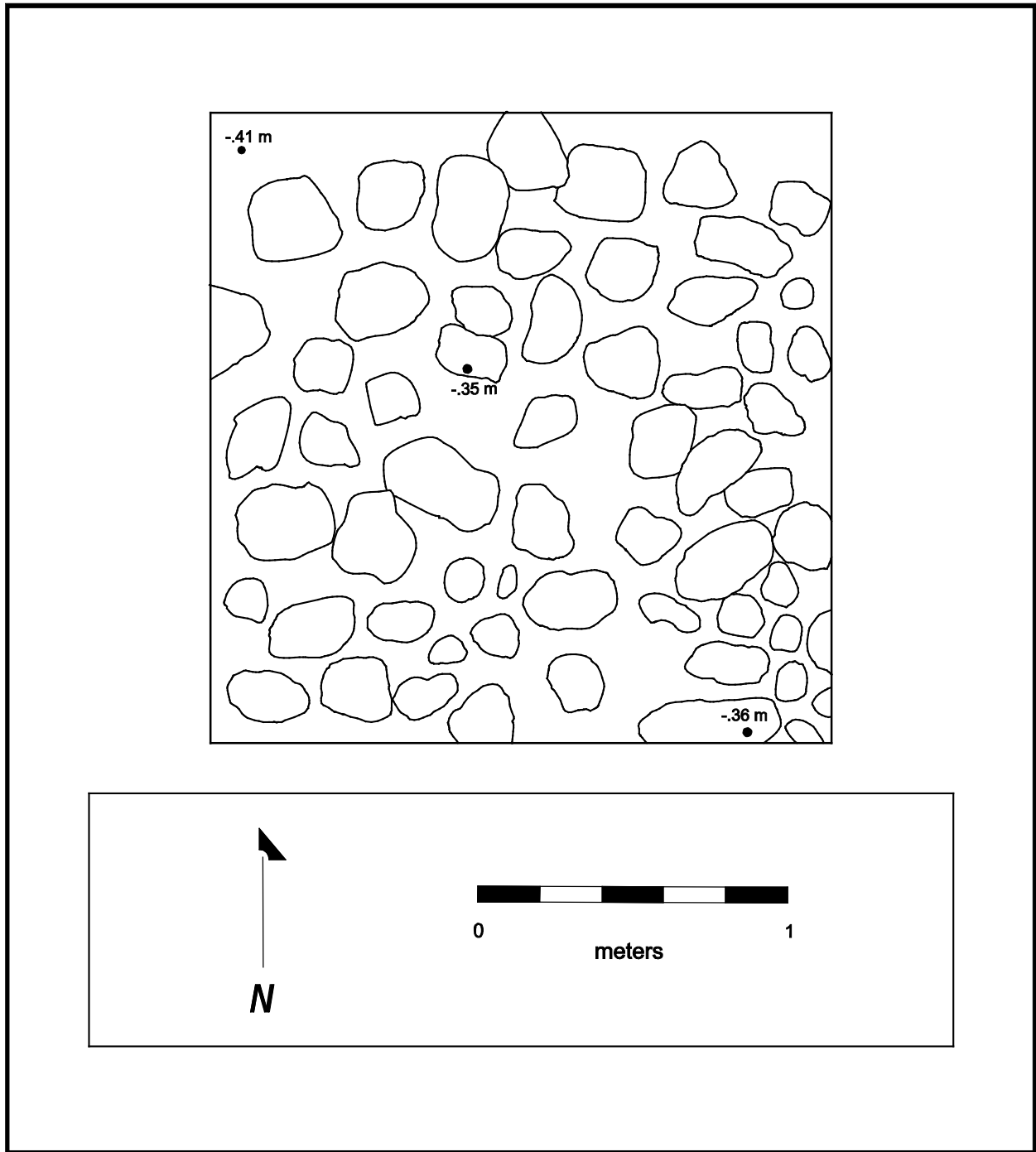

Figure 76. Ramonal Quemado, Operation 2, Level 3, Lot 1

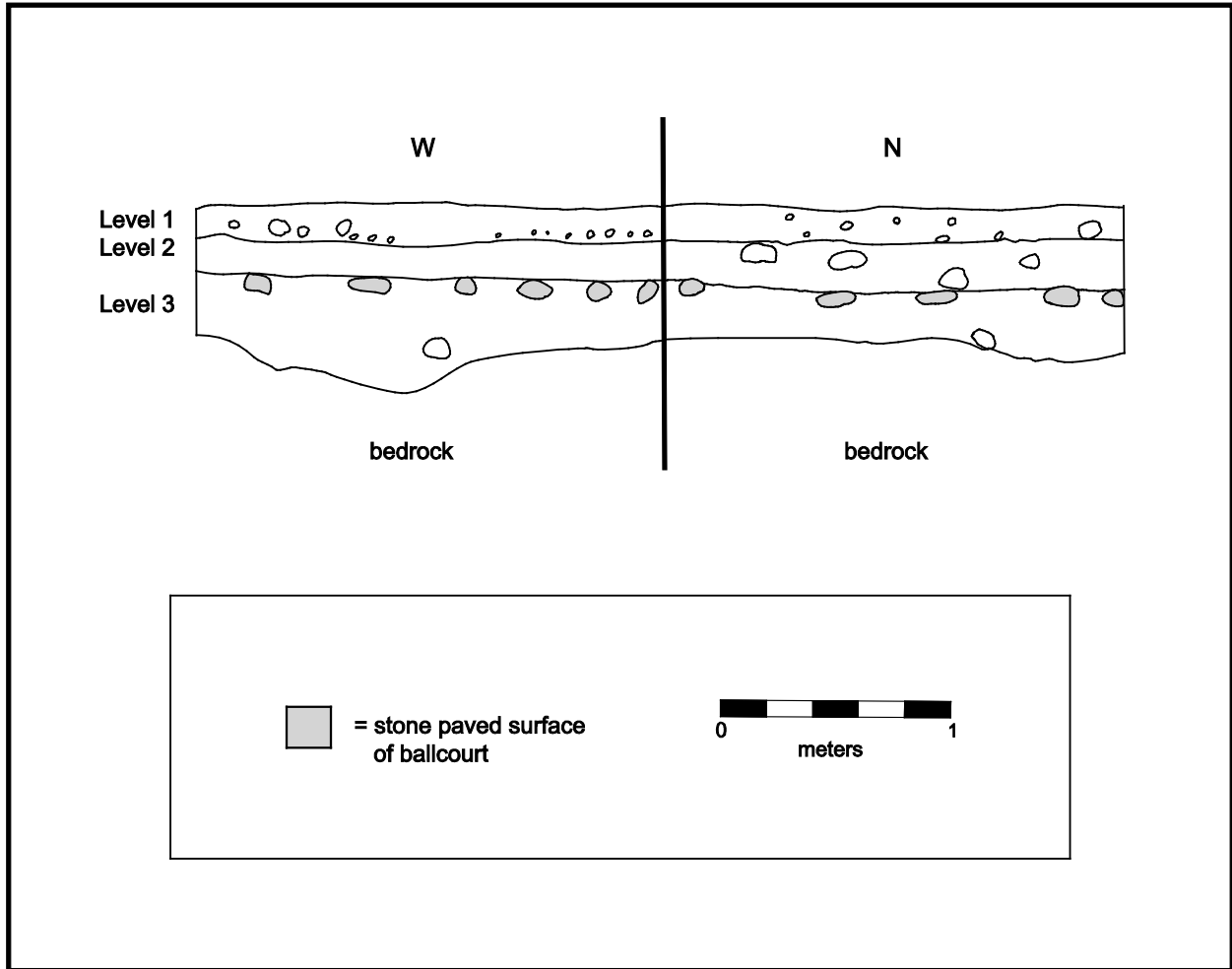

Figure 77. Ramonal Quemado, Operation 2, West and North Profiles

stones, probably once covered with plaster, which corresponds to the pavement found at Level 3, Lot 1. According to data from Operation 3, the time of the construction of this complex, and the pavement, must have been during the Terminal Classic (see Chapter 29 this volume). Following this, the site fell into disuse and the lack of maintenance caused a lot of sediment to coat the surface of the court, which corresponds to Level 2 and Level 1 of this operation. This process spanned from the time when the site was abandoned to the present day. This great accumulation of sediment is because the slope of the two side structures facilitated the accumulation of sediment, which tends to accumulate in this area of the complex instead of its sides. However, not many stones from the collapse of the nearby structures (Structures and S1W1-5 and S1W1-6) were found in the test pit area. Perhaps the lateral structures were not so high, thus the collapsed stones weren't displaced by several meters, but the stones fell close to the other structures.

Despite not having obtained dateable material from this unit, its dating is possible based upon Operation 3, although these data are not, in any way, definite. However, what can be conclude is that this part of the settlement was built in one single phase, perhaps during the Terminal Classic, as evidenced in the subfloor that was the base of a once-plastered surface. Furthermore, it seems to be that there was no Postclassic occupation in this area of the settlement (see Chapter 27 this volume). Future excavations of test pits in other areas of the complex of the ballcourt may give us a greater certainty about the period in which it was conceived and constructed.

Part 4: The *Ejido* of San Felipe

Chapter 29: Ramonal Quemado, Operation 3

Justine M. Shaw and Vania Carrillo Bosch

As part of the CRAS Project's aims for 2010, a series of test pits were excavated in order to document the chronology and cultural affiliation of the site of Ramonal Quemado. Operation 3 was a 2 x 2 m test pit, located near the northern structure of the ballcourt, within the area of the playing field. Excavation began with arbitrary metric levels, which allow us to have a better control to detect possible anomalies or changes in strata in order to find natural or cultural levels.

The surface where the unit was located is composed of a very dark brown sediment (7.5YR 2.5/3), with abundant organic material, mainly due to the large quantity of dead leaves produced by the secondary forest growth. Level 1, Lot 1 was formed by a very dark brown (7.5YR 2.5/3) deposit, mixed with compacted soil and fine roots. Ceramics recovered in this level mainly correspond to Terminal Classic (Teabo Red) ceramic types, but no large quantities were collected. At 10 cm below the surface, Level 2, Lot 1 was begun, although the color of sediment was very similar than the one of the previous level. Level 2, Lot 2 (Figure 78), consisted of a section (of 150 x 35 cm) of a plaza plastered floor, grayish in color (2.5 Y 6/1), while the base of this floor was whiter (2.5 Y 8/1). Ceramic material recovered in this operation includes primarily Muna Slate ceramics. Operation 3, Level 3, Lot 1 was formed by a dark yellowish brown sediment (10 YR 3 / 4), with the presence of small stones (3 to 8 cm) and little pieces of a weathered white stucco (2.5 Y 8/1). This concentration of plaster sections was nucleated at the central and southwestern part of the pit. Small stones were the subfloor of an elaborated plaster floor (Level 4, Lot 1). Below this, Level 5, Lot 1, a layer of red soil or *chac luum* was located. The ceramic material recovered in this deposit corresponds to the Late Formative (Sierra Red). Under this level, the last layer was found, which ended with the discovery of bedrock or *chaltún* in Yucatec Maya (Figure 79). Excavation of this unit concluded at 138 cm depth.

Interpretation

Based upon the stratigraphy and ceramic analysis, we propose the following chronological sequence. According to this analysis, we believe that the first settlement in this part of the site occurred during the Late Formative period, corresponding with Level 5, and apparently there were no permanent constructions in the immediate vicinity. Subsequently, by means of the placement of a dirt fill along with several small stones, a flat and horizontal surface was raised to form a paved surface or subfloor that served as the base for a plaster floor, perhaps the final surface of the playing field of the ballcourt. Within Level 2, Lot 2, a grayish stucco floor (2.5 Y 6/1) was found; it may have acquired this coloration due to prolonged exposure to an intense fire. Therefore we propose two hypotheses to understand this evidence. The first one is that there may have been a fire that occurred in this part of the settlement during this period or, the

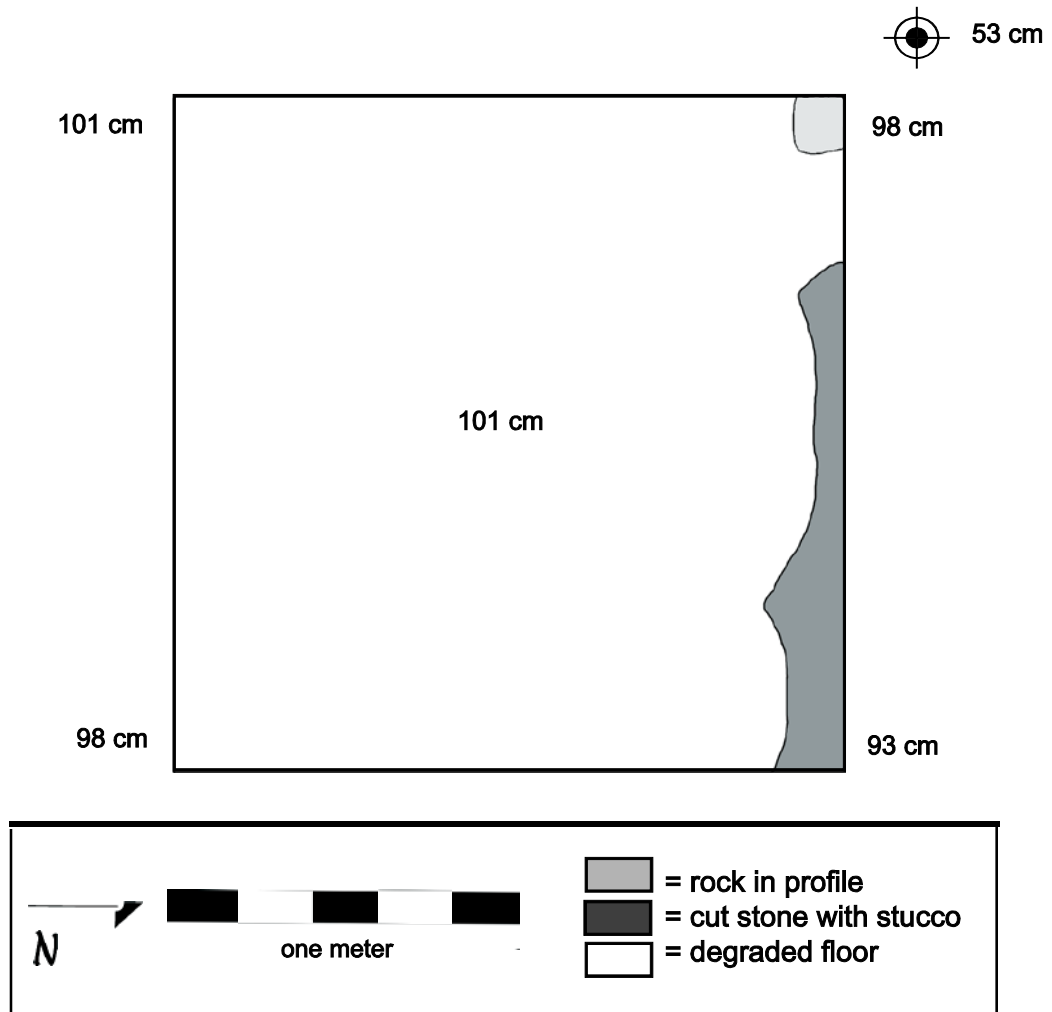

Figure 78. Ramonal Quemado, Operation 3, Level 2, Lot 1

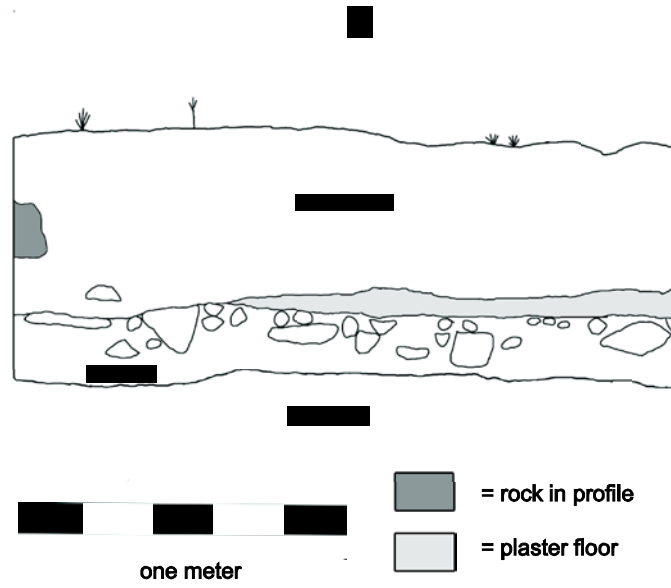

Figure 79. Ramonal Quemado, Operation 3, North Profile

second, this color is caused by a prolonged exposure to a stove placed in this section of the ballcourt. Three previous levels were formed, according to the ceramic analysis, during Terminal Classic. No Postclassic ceramic sherds were found in this unit.

Evidence from other units within this settlement will help us to understand the occupations and chronological sequence, as well as perhaps to verify whether or not an intense fire occurred during the Terminal Classic period. Alternately, perhaps when this site was already abandoned, some new occupants placed a fire within the area of the northern terminus of the ballcourt. Both hypotheses imply different results in terms of cultural activities that occurred at the site of Ramonal Quemado, ideas that will be investigated in future.

Part 4: The *Ejido* of San Felipe

Chapter 30: Ramonal Quemado, Operation 4

Justine M. Shaw and Luis Fernando Hernández Lara

Operation 4 was placed in an open space close to the northern side of Structure N1W1-1. The surface was composed of organic material (dead leaves) from the secondary forest vegetation of the vicinity and some pebbles from 2 to 4 cm in diameter. Operation 4 was a 2 x 2 m test pit; arbitrary 10-cm levels were used until a cultural context was located and then the excavation changed to cultural levels.

Level 1, Lot 1 was a mixture of pebbles from 2 to 4 cm on average and two larger rocks. The ceramic material corresponds to the Terminal Classic, including Yokat Striated, Muna Slate, and Teabo Red, but also there are intrusions of Late Formative material (Sierra Red, Laguna Verde Incised) perhaps from the fill of Structure N1W1-1 or the removal of land by humans as part of the agricultural labors. Also, in this level, a piece of lithic (chert) was located.

Beneath this layer was Level 2, Lot 1, consisting of several small stones (gravel) and some rocks from 10 to 20 cm on average. No stucco chunk or fragment was located, thus it is probable that this surface was exposed to the environment and consequently has been degraded. Ceramics found in this level are from three different periods: the Late Formative, Early Classic and Terminal Classic. In addition, two pieces of lithics and a ceramic bead were found. The layer was about 10 cm thick.

Immediately following this, Level 3, Lot 1 was initiated. It consisted of several rocks, from 20 to 50 cm in diameter, that served as a fill or subfloor, in order to level and create a base for a plaster floor. Therefore, we suppose that a floor had existed in the previous level. Pottery from this level corresponds chronologically to the Middle and Late Formative, with sherds from the latter period being more numerous (Figure 80).

Under this deposit was Level 4, Lot 1, a light brown (2.5 YR 3/3) soil, which usually precedes the bedrock and, in the absence of cultural finds it was decided to change to metric arbitrary levels (of 10 cm). However, bedrock was discovered almost immediately. The ceramic sample from this level was scarce and consisted of only two fragments that belong to the Early Classic period, which is inconsistent with the ceramics of earlier levels, so they may be intrusions that fell from the upper levels (Figure 81).

Interpretation

According to the ceramics samples recovered in this operation, the occupation of this area of the settlement began in the Middle Formative or Late Classic (using old fill material) with the placement of subfloor or base to level the area. However, no remains of what may have been a plastered surface like a floor or a compaction of soil or activity area were found.

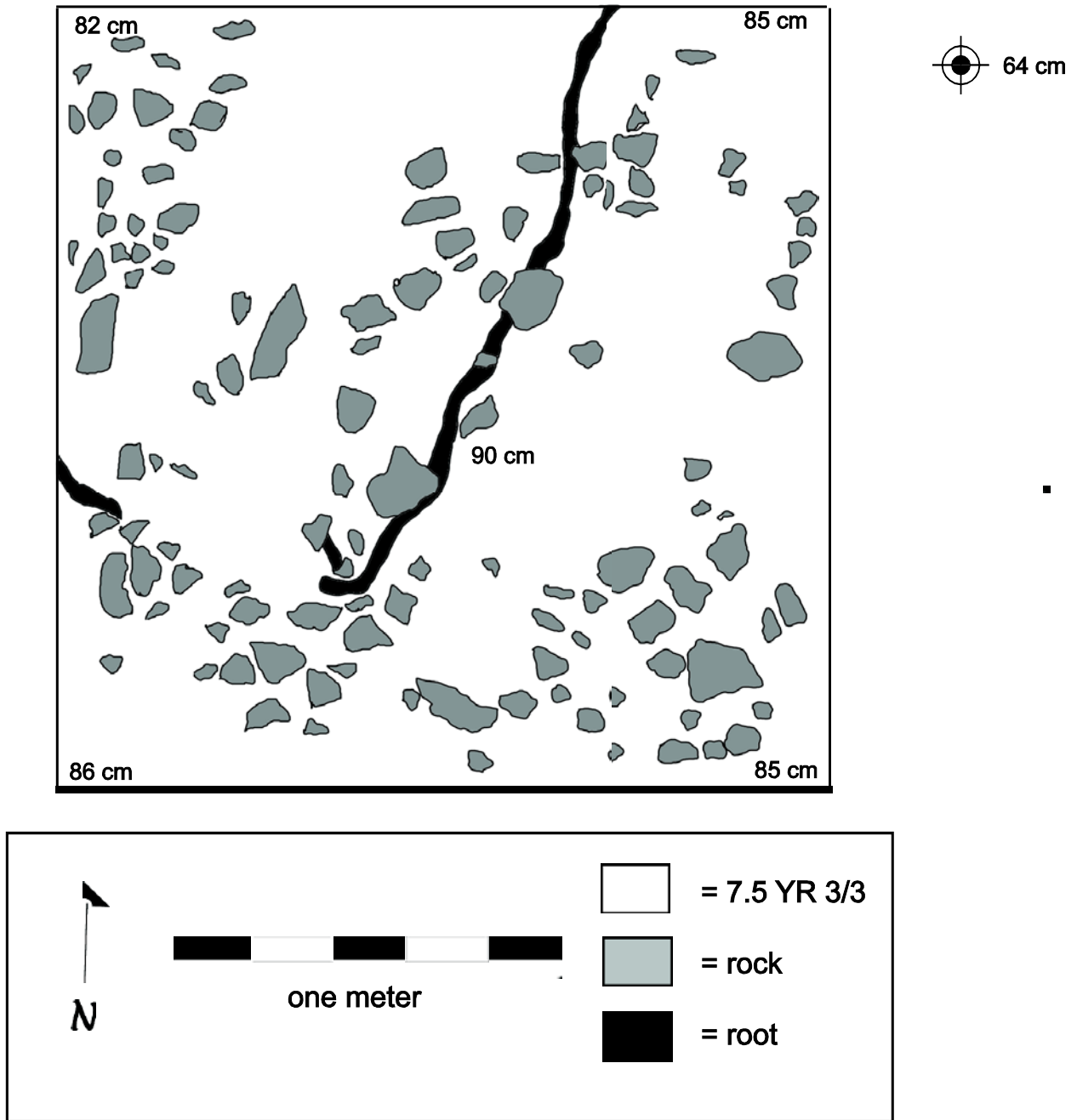

Figure 80. Ramonal Quemado, Operation 4, Level 3, Plan Map

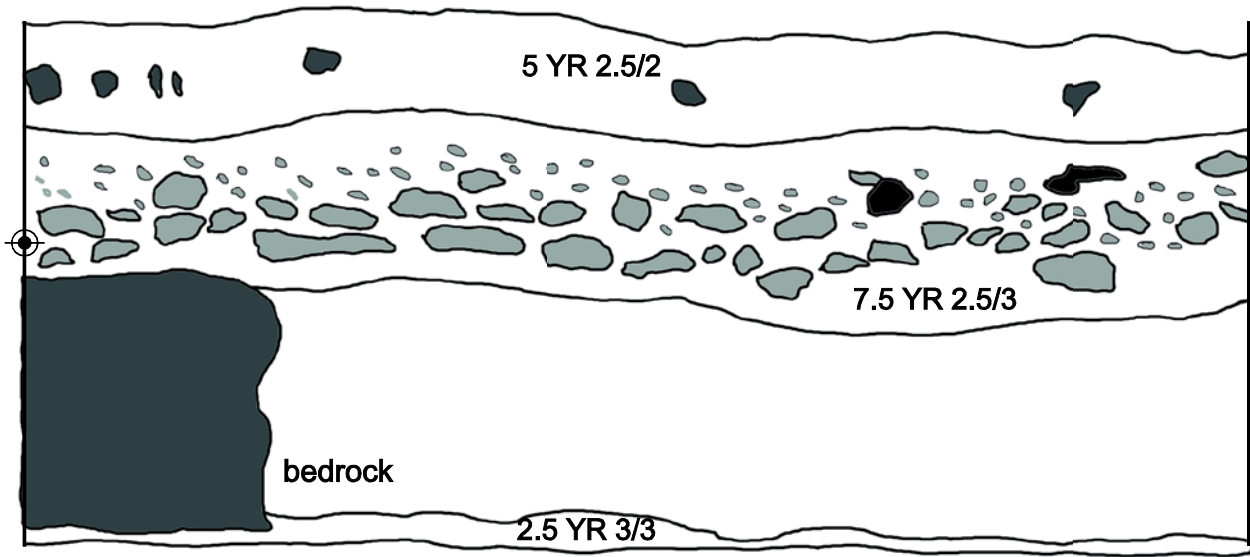

Figure 81. Ramonal Quemado, Operation 4, North Profile

Atop this subfloor was a deposit of pebbles or gravel, which may have been used as the mortar for a plaster floor, but no remains of a stucco or polished surface were located. This is probably due to its degraded condition because of a long exposure to the environment, although another hypothesis is that this plaster surface never existed, which indicates that the construction project was unfinished. Ceramic sherds found at this level range from the Middle Formative through Terminal Classic period; the second is which dates this stratum.

Most representative sample is that of the Terminal Classic, which indicates that during this time the occupation of the site was more intense. The earliest ceramics have been included as fill and do not reflect an occupation within the area of the test pit. Evidence and the context of this unit indicates that, since this was a public space, the material used in the construction of the floor was not of a very good in quality or was exposed, for a long period, to erosion from the elements, which explains its degradation.

This area seems to have been abandoned by the end of this period (Terminal Classic) when its occupation was more intense, since no samples from later periods were found.

Part 4: The *Ejido* of San Felipe

Chapter 31: Ramonal Quemado, Operation 5

Justine M. Shaw, Thania E. Ibarra Narváez and Alberto G. Flores Colin

Operation 5 in Quemado Ramonal was a 2x2 test pit, located in a plaza that was relatively private and just to the north side of one of the structures that define this area (Structure N1W1-1). Operation 5 included six levels, of which only the first one was excavated as arbitrary level, while other five were divided as cultural levels (Figure 82).

Level 1, Lot 1 was a 10-cm arbitrarily layer, since there were no cultural features. It was composed of a reddish black color sediment. Ceramic material located was relatively scarce, mostly consisting of Muna Slate, but with some sherds from the Late Formative and Postclassic periods. After this several stones from the collapse of the building located next to the operation were found; thus, it was decided to change to a cultural level, Level 2, Lot 1 (Figure 83). In addition to rocks from the collapse, the layer was comprised of black soil and a few ceramic samples. Among the ceramics, most are Muna Slates, although there was a sherd that belongs to the Middle Formative.

With the removal of the collapsed rocks, we noticed that one part of the pit was covered with stones, while the other section has no rocks. Thus, it was decided to change to Level 3 and divide the unit into two lots: Lot 1 for the area lacking rocks and Lot 2 for the other with several stones. Level 3, Lot 1 was composed entirely of a black color soil, like the last level, but the ceramic material was very scarce, containing only four identifiable sherds, two from the Late Formative (Sierra Red type) and the other two dated to the Early Classic. Within Level 3, Lot 2, we still found rocks from the collapse. The soil was still black and the ceramic material included Teabo Red and Yokat Striated types from the Terminal Classic, but also with a single Sierra Red sherd from the Late Formative.

After all rocks from the collapse were removed, we found a pavement of rocks, labeled as Level 4. Sediment from this level was dark reddish brown. Ceramics collected are Muna Slates, which may indicate that the sample was Terminal Classic in date. Due some Late Formative sherds was located below this pavement; we conclude that this layer dates after this said period. Surely, the collapse of the building occurred before the Postclassic, since no ceramic material from that period was located over the pavement. Apparently the period of greatest activity of the immediate surface of the pavement was the Terminal Classic, as only ceramics from this period were found.

Immediately after the pavement, we noticed a change in the cultural stratigraphy, thus the layer was changed to Level 5 (Figure 84). Level 5, Lot 1 consisted of dry core fill without mortar.

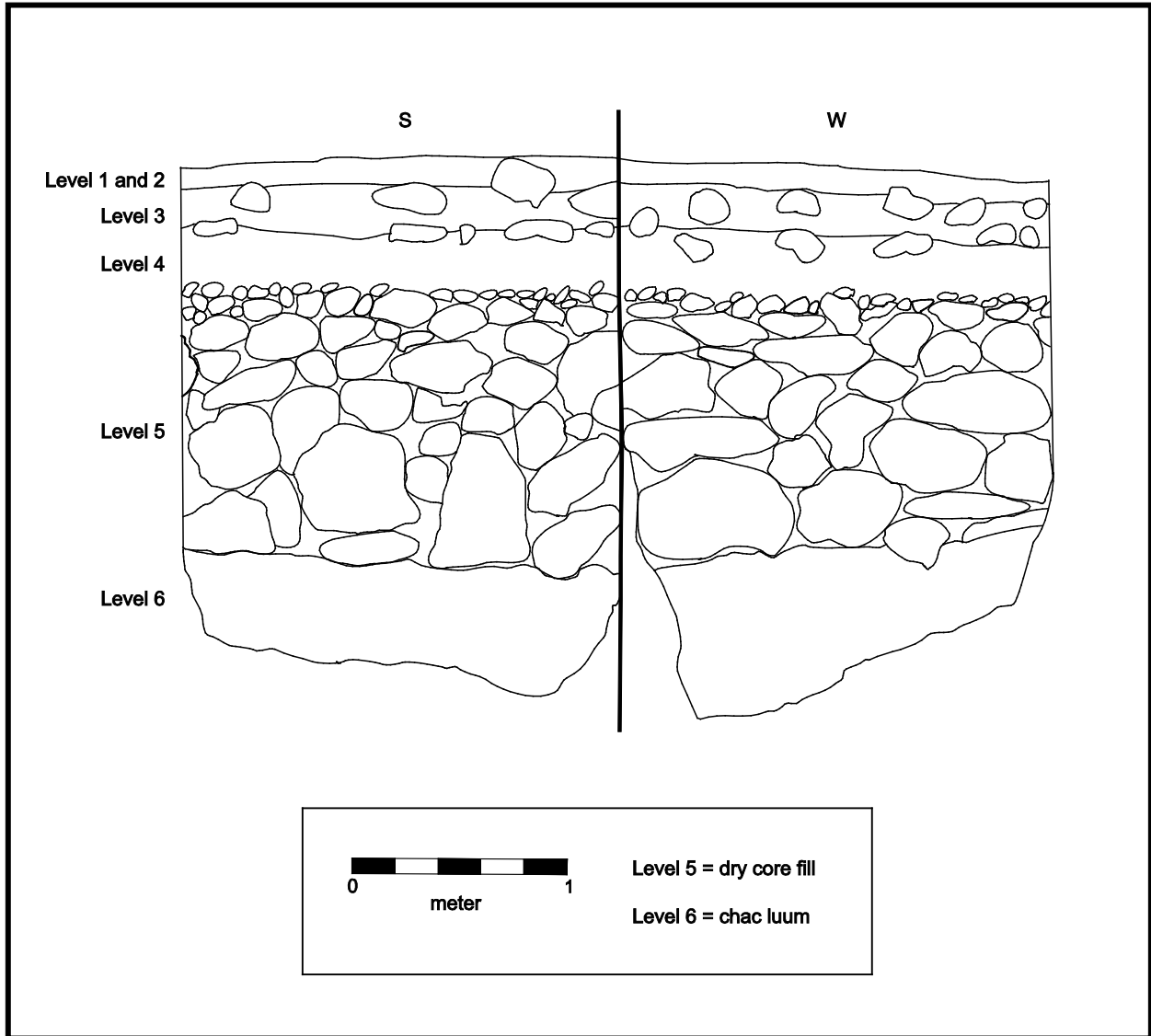

Figure 82. Ramonal Quemado, Operation 5, South and West profiles

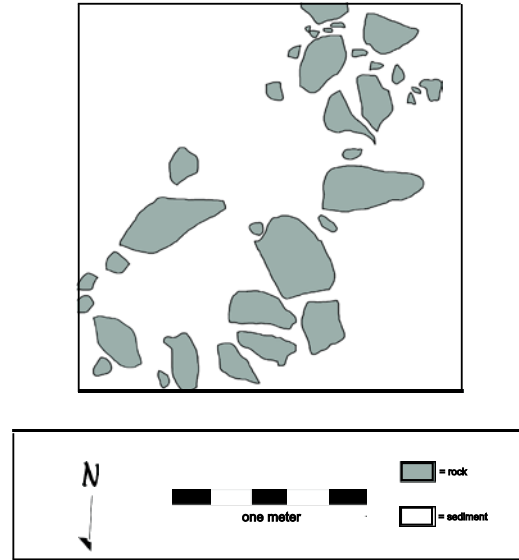

Figure 83. Ramonal Quemado, Operation 5, Level 2

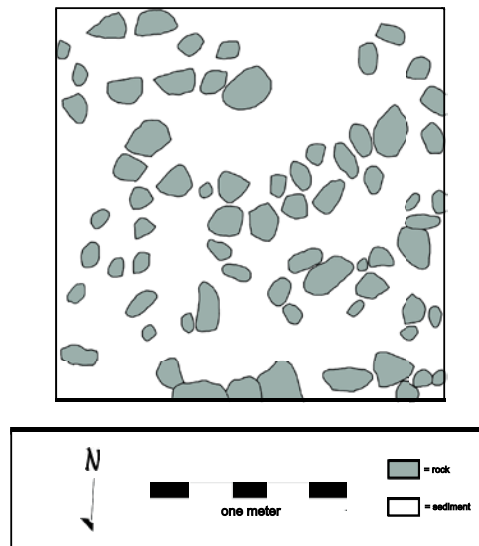

Figure 84. Ramonal Quemado, Operation 5, Level 4

The smallest rocks were about 20 x 20 cm (at the top of the core), while others still larger (about 70 x 60 cm) lay at the bottom. This arrangement appears to provide greater stability to the raised plaza, as larger stones would give a broader base to the smaller; furthermore to put larger stones in the upper parts would require more effort. This fill is the base of a plaster floor that must have been the first surface of the plaza, and surely existed in Level 4, Lot 1, but is now degraded. This construction event includes Levels 4 and 5, in which the plaza was raised upon 1.40 m on average above the surface, and thus the plaza was shaped into a delimited, restricted and more private space. In addition to this, this plaza is where the tallest structure in the settlement (Structure N1W1-2) lies, which suggests a certain importance with respect to other areas. According to data from other operations (see Operations 2, 3 and 4), in this area is where the greatest construction effort was invested in whole site, considering that the plaza area, about 50 x 50 m, was raised by about one and half meters with respect to the surrounding terrain. Due to their condition, the majority of sherds found at this level could not be identified. However, two Early Preclassic samples were registered. However, this level dates to the Terminal Classic, since this is the date of Level 4, Lot 1, which corresponded to the surface of the plaza during its final construction event, that includes both Level 4 and Level 5.

It has to be noted that in the west wall of the unit a line of well-arranged stones was visible, which formed a sort of a construction box. Construction boxes are often formed by masonry walls, built to provide greater stability to the core of the structures (Gendrop 1997). This potential box wall was instead a line of stones, without mortar, but some stones were some stabilized with wedges and specially arranged compared to rest of the stones that lay without any apparent order. Due to the size of the unit, it was not possible to observe if this feature continued for some distance, thus it was not fully defined, making it impossible to test our hypothesis.

Close to the bottom, and just before the bedrock, was a small deposit of *chac luum*, which was named Level 6, Lot 1. This layer was red in color. After Level 6, *laja* or bedrock was found and the excavations were concluded. At the completion of the appropriate recording (which included notes, drawings and photographs), the operation was backfilled to the original surface level.

Part 4: The *Ejido* of San Felipe

Chapter 32: San Felipe, Operation 2

Justine M. Shaw and Vania Carrillo Bosch

As part of the CRAS Project goals, a series of operations was carried out at this site in order to document its chronology and cultural affiliation. Operation 2 was a 2x2-m test pit, located next to a "C"-shaped structure, Structure N3E4-6 (Figure 85). Excavation began through the implementation of arbitrary metric levels, which could keep a meticulous register until natural and/or cultural levels marked a change in strata.

The area of this excavation was surrounded by several bushes and high grass; the test pit surface was covered by a small amount of dead leaves, residue of the nearby vegetation. The surface was composed of a very dark brown color sediment (7.5YR 3/2), soft and easy to handle because the land was used previously for growing corn and was currently being grazed by sheep. Level 1, Lot 1 was formed by very dark brown sediment (7.5YR 3/2), with a high content of organic material, mainly roots, as well as a few small to medium sized (5 to 30 cm) stones. A significant amount of ceramic material was found in this layer; it was mostly corresponds to Postclassic types (including Mama Red). After the removal of this level, Level 2, Lot 1 was found, which consisted of dark brown sediment (7.5 YR 3/3), claylike and very malleable. This kind of soil is the characteristic *chac luum*, a natural layer that, in many places, lies directly upon bedrock. It is rich in iron and reddish in appearance. No large quantities of ceramic material were found in this level; those that were mostly belong to the Terminal Classic (Ticul Thin Slate). Below this level, the last layer was found (Figure 86), which consisted of bedrock or *chultun* in Maya Yucatec (Figure 87). Excavation of this unit concluded at a depth of 104 cm.

Interpretation

Based on ceramic analysis and stratigraphy of this operation, we propose the following chronological sequence. According to ceramic material, we can deduce that the first settlement occurred during Terminal Classic. It is suggested that the ceramic material found within this level served as a construction fill for the creation of Level 1, since said level was a horizontal and raised surface.

Although there is no conclusive evidence, it appears that a Postclassic occupation did exist. The ceramic material found is quite mixed; this indicates that farming labors may have removed the sediment and mixed ceramic material from different layers. Evidence and information obtained in the other units of this site (see the following chapters) will help us to better understand the occupation and the chronological sequence of this settlement.

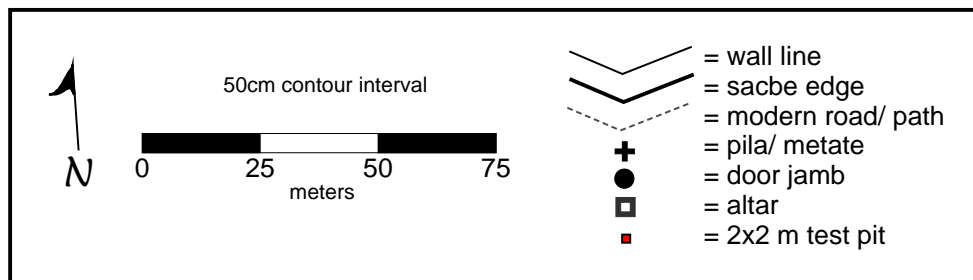
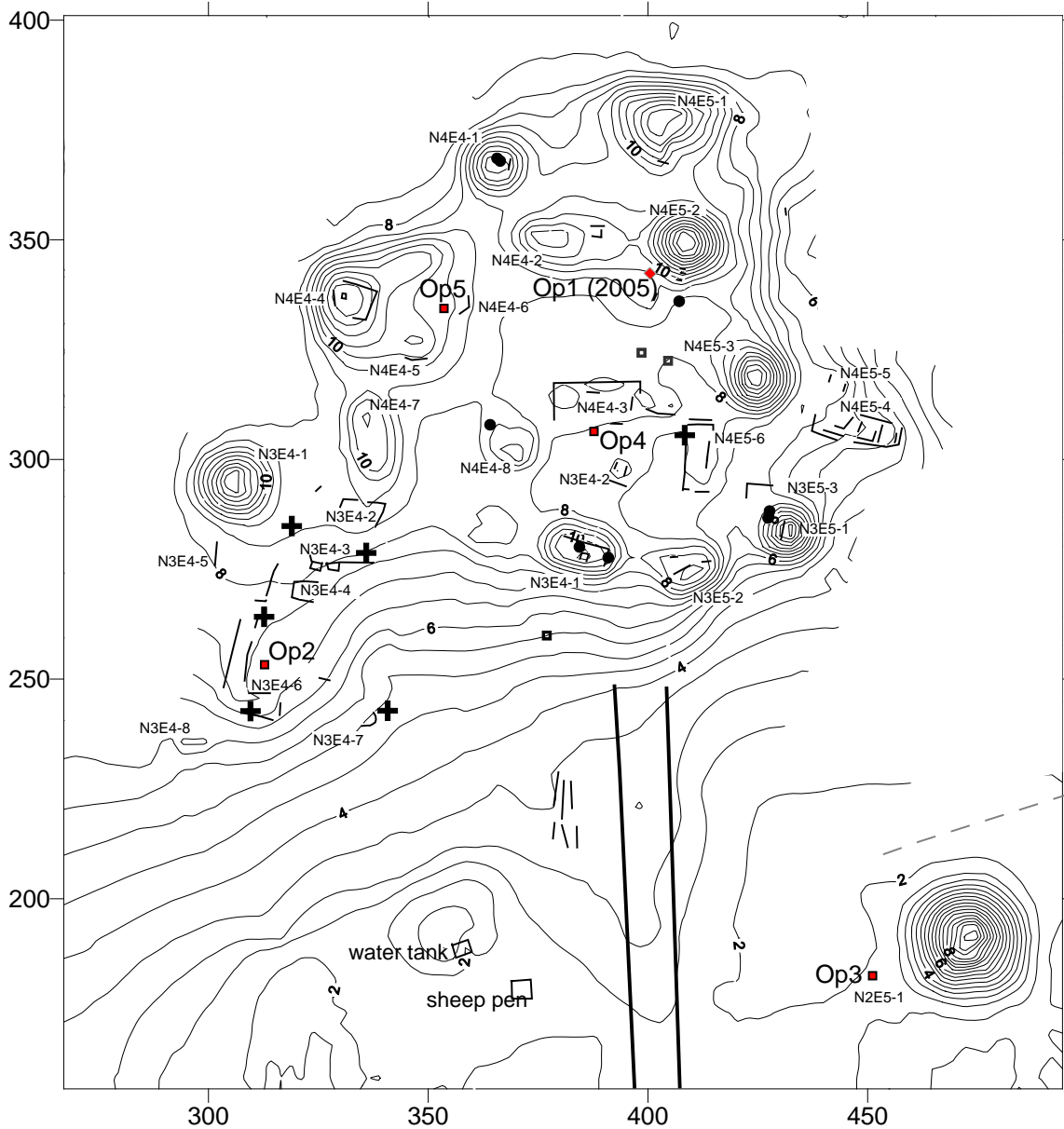

Figure 85. San Felipe, Location of Excavations

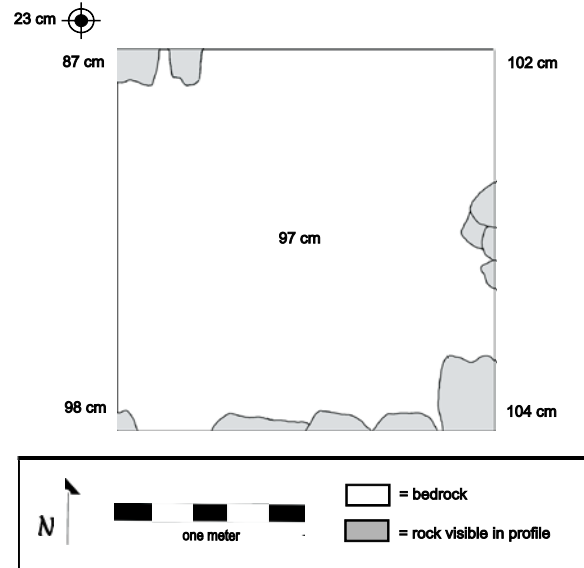

Figure 86. San Felipe, Operation 2, Bedrock

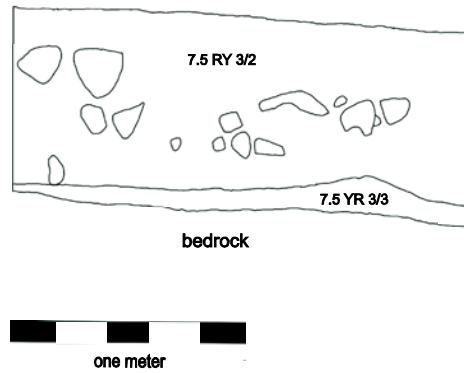

Figure 87. San Felipe, Operation 2, North Profile

Part 4: The *Ejido* of San Felipe

Chapter 33: San Felipe, Operation 3

Justine M. Shaw and Luis Fernando Hernández Lara

Operation 3 is located east of Structure N2E5-1 (Figure 85), and consisted of a 2 x 2-m test pit. Its surface was covered with organic material that grew up and/or had fallen from nearby trees. Excavation began using arbitrary metric levels, of 10 cm each, until locating cultural layers, then was changed to cultural levels.

Level 1, Lot 2 revealed Feature 1, a circular wall located in the northern area of the unit, composed by stone blocks of about 40 cm in width. It was not possible to identify the ceramics that came from the outside (north) of this feature. South of this wall was a thin layer of pebbles (from 2 to 5 cm), that would correspond to the interior pavement of Feature 1 and was named as Level 1, Lot 1. Ceramics located within this layer mostly correspond to the Terminal Classic, but also include some Postclassic sherds, of the Chen Mul Modeled type, as well as a piece of obsidian blade (Figure 88).

After this level, it was decided not continue with the excavation of Level 1, Lot 2 (the area north of Feature 1), in order to not affect its stability and then consolidate it according with the guidelines enunciated below. At Level 2, Lot 1, a base of stones from 10 to 60 cm was located, including some blocks very similar in shape to those that comprise Feature 1. The most abundant ceramics are from the Terminal Classic and only two fragments are from the Late Formative.

Under this cultural layer was Level 3, Lot 1. This level was composed of a very red, muddy and highly compacted soil, which is locally called as *chac luum*, with a single stone. Ceramic material was scarce and mostly corresponds to the Middle and Late Formative. This level was arbitrarily concluded because its last 40 cm was culturally sterile (Figure 89).

Interpretation

Ceramic analysis indicates that the occupation of this part of the site began in the Middle Formative, since some samples of this material were found in the oldest deposits that lie directly within the *chac luum* (once the natural surface), then a base or subfloor was placed during Terminal Classic (due the abundance of ceramic material), which was covered by a *sascab* or plaster floor. Apparently then the area was abandoned and may have been a latter re-occupation during the Postclassic, although this must have been very limited.

In the beginning, it was thought that the wall defining the interior of Feature 1 belonged to a later construction than Structure N2E5-1, a pyramidal mound located to east, and the subfloor and the wall itself were made with re-used material from that structure. Since that the majority of the constructions at this site and the others nearby (Ramonal Quemado, Sisal) have their primary construction period

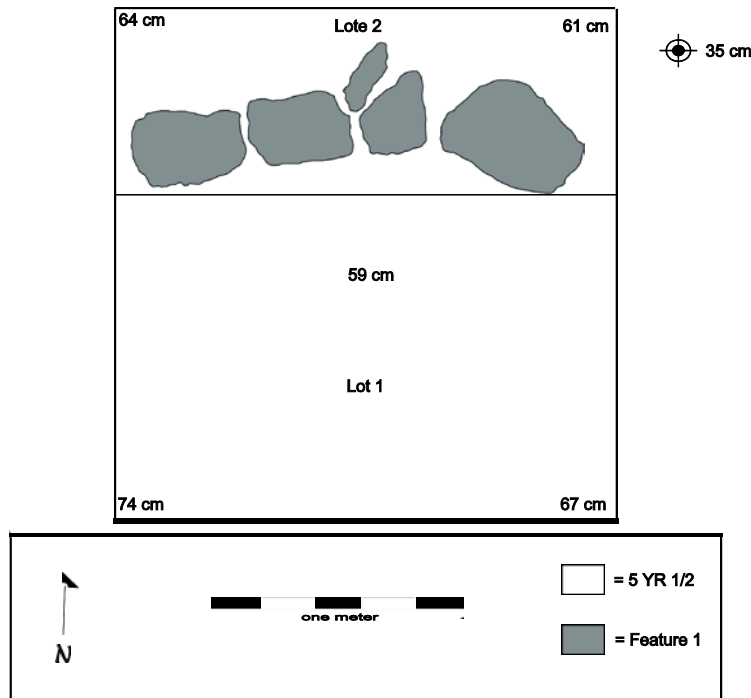

Figure 88. San Felipe, Operation 3, Level 1, Wall

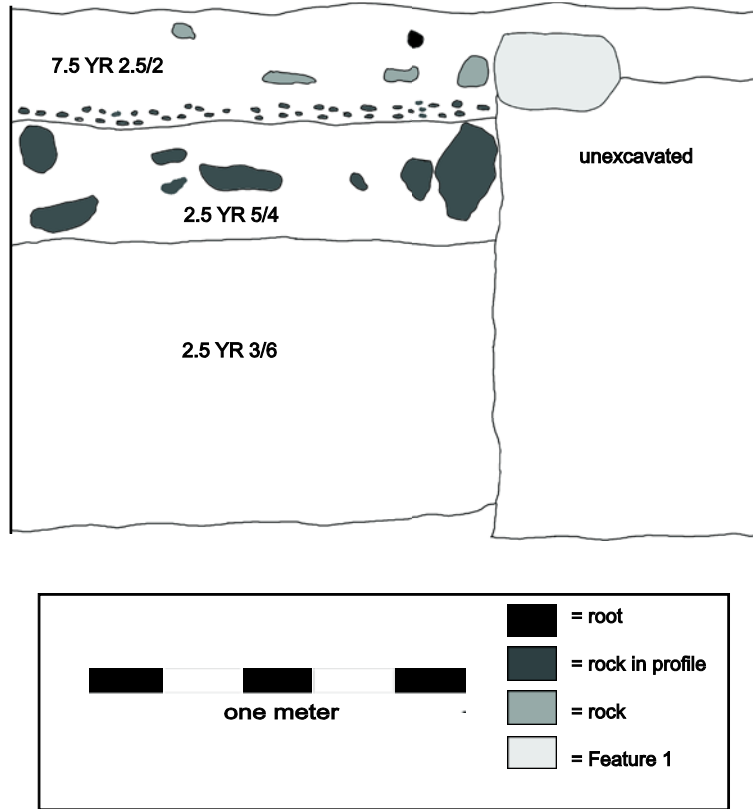

Figure 89. San Felipe, Operation 3, West Profile

during the Terminal Classic, and the ceramics within Feature 1, the subfloor, and the *sascab* date to this period, it seems that the structure of which Feature 1 is a part and Structure N2E2-1 are roughly contemporary. Because only a small section of Feature 1 was excavated, is not possible determine its function, although it appears to be part of a circular foundation brace, which, due its position within the plaza (one of the main areas in whole settlement), may have a public function or postdated other activities in the plaza.

Consolidation

Feature 1, a low, curving wall was found in the northern part of the unit and was left *in situ* for further consolidation at the end of the excavation process. Said labor began with the cleaning of the stones that shape the wall and then proceeded with the placement of new mortar (composed of 3 parts of lime, 3 parts *sascab* and 1 part of white cement). All this was carried out in order to ensure their preservation and stability in the future. Once this necessary process was concluded, and after the proper documentation through drawings and photographs (Figure 90), the unit was backfilled to its original level, covering the feature.



Figure 90. San Felipe, Operation 3, Feature 1

Part 4: The *Ejido* of San Felipe

Chapter 34: San Felipe, Operations 4 and 5

Alberto G. Flores Colin and Justine M. Shaw

Operations 4 and 5 were conducted to obtain additional ceramic samples from the center of this Prehispanic site of San Felipe. Both units were 2 x 2-m test pits, conducted in areas located near, but never affecting, the architecture visible on the surface. Operation 4 was located south of Structure N4E4-3, while the Operation 5 was excavated east of the structure N4E4-4 (Figure 85).

Operation 4

Operation 4 started with an arbitrary level of 10 cm, which consisted of a dark brown silty soil (7.5YR 3 / 2), with roots and some limestone ranging from gravel size to the boulders. This level was followed by a level of 13 cm, Level 2, Lot 1, consisting of the same material. Approximately 23 cm below the surface, a plaster floor (Floor 1) was found that was largely intact over the majority of the unit area (Figure 91). Ceramics above the floor belonged mostly to the Terminal Classic. This deposit was removed as two lots, one for the sealed area of the floor and the other to the degraded section. Level 3, Lot 1 began after the previous lots were removed, at the point where the entire unit presented a uniform deposit of gravel and other stones that were slightly larger, locally known as *chich*. This layer was brown (7.5YR 5/3) in color. Floor 1, as well as its subfloor, also dated to the Terminal Classic.

At a depth of 60 m, a second floor was located. Although it lay intact over the entire unit, the surface looked rough and eroded, with no polished fragments. This layer was slightly lighter (brown 7.5 YR 4/3) than the sediment that covered it. Sherds recovered from this deposit allowed us to assign it to the Terminal Classic. After removal of the Level 4, Lot 1, about 10 cm below, a third floor was located. This floor was equivalent in color to the second floor. The surface of this floor was also rugged and intact, with the exception of a small hole (20 x 20 x 7 cm) close to the southeast corner (removed as Level 5, Lot 1). The remainder of Floor 3, Level 5, Lot 2, was relatively soft and its base or subfloor consisted of a *chich* (gravel) deposit. Following the third floor, and immediately below, a fourth floor was discovered (Level 6, Lot 1). The color of the latter (Floor 4) was very similar to Level 5, Lot 1, and consisted of *sascab* and *chich* stones. Level 7, Lot 1 corresponded to the subfloor of the fourth floor, which was composed of *chich* stones or gravel, as well as some slightly larger stones, about 10 x 15 cm on average. Both Floor 3 and Floor 4, with their respective sub-floors, seem to belong to the Early Classic. Below this, a fifth floor (Level 8) was located, which had a missing section on the southeast corner that appeared to be a post hole (Lot 1). The rest of the unit showed an eroded surface that was still complete (Lot 2). The color of Floor Five was whitish brown (5 YR 5/6), and consisted of *sascab* and gravel (*chich*). No sherds were found within these layers. The next layer consisted of a series of large stones, about 40 x 40 in average, used as 60-70-cm-thick dry core fill,

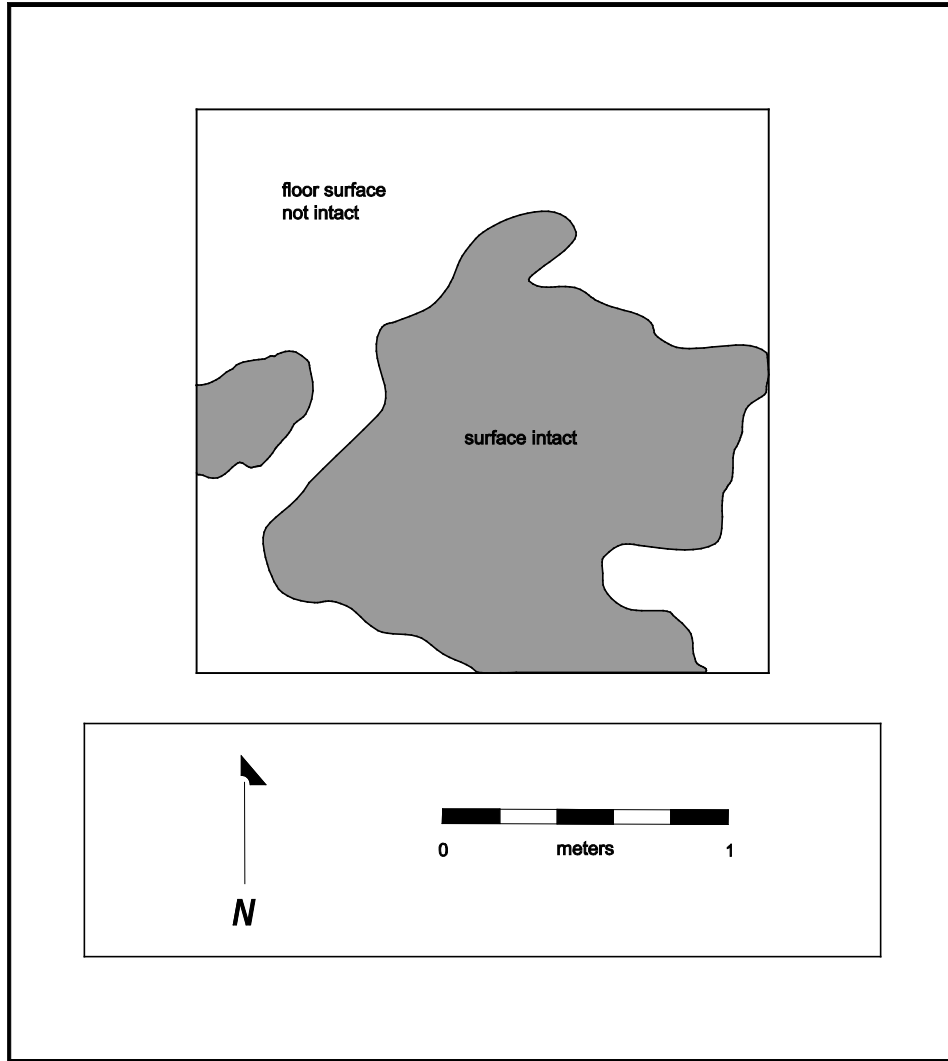

Figure 91. San Felipe, Operation 4, Level 3, Lots 1 and 2

which was laid down from largest to smallest size in descending order (Level 9, Lot 1). Beneath this dry core fill, a red soil layer or *chac luum*, preceded the *laja* or bedrock. During the process of removing these large stones, as well as the consistency of *chac luum*, the materials in both layers were intermixed, so these two layers were recorded as the same level and lot. Ceramically, these two layers contain a substantial amount of material from the Early Classic, but we also found a significant amount of Terminal Classic sherds. We assume that this mixture is the result of the collapse of some sections of the profiles of the unit, caused by the removal of large stones that were the base to other smaller and superficial, linked to the profiles of the unit, but also, it is possible, that this mixture is accurate. Excavation of a new unit on another nearby location will help to clarify this dilemma in the future. Once the last layer was removed, the surface of the bedrock was cleaned and the proper registration tasks were conducted (Figure 92). Upon conclusion of above-mentioned labors, the excavation was backfilled entirety to reach the original surface.

Operation 5

Operation 5 also started with an arbitrary level of 13 cm, Level 1, Lot 1, consisting of a silty very dark brown sediment (7.5YR 2.5/2) and a few roots. From this point (Level 2, Lot 1) the number of stones of boulders size increased, but the sediment had the same makeup as that the previous level. Based on the collected ceramics, these two levels are from Terminal Classic.

About 40 cm below the previous level, the sediment changed to a grayish color (2.5Y 5/2, grayish brown), with a greater compaction. This deposit (Level 3, Lot 1) seemed to be the remnant of a plaza floor, but lacked a well-preserved and intact surface; the stucco was mixed with a similar sediment to that of the two previous levels. The deposit was about 10 cm thick, and underneath we found that the context of the unit was divided into two quite equal halves. The middle of the unit was marked by a line of six well-cut stones (Level 3, Lot 1). To the north of the line, several medium and large stones that filled the entire half of the unit were located (the tops of these stones were at the same level as the six well-cut stones that divided the unit), while in the southern half of the unit continued with the same sediment as the previous level (Level 3, Lot 1). For this reason, we decided to leave the stones intact until we had a better idea of what the feature might be. The southern part was removed as Level 3, Lot 2, which revealed the presence of a second stucco floor, well preserved at a depth of about 53 cm. Part of the floor was curved up to cover the lower parts of the well-cut stones on the northern half of the unit, which suggests that they once coated Feature 1. The removal of Level 3, Lot 2 confirms for us that these stones were part of the outer wall of what appears to be a platform or bench (Feature 1), which was left intact for its subsequent consolidation (Figure 93). Ceramics located above this floor and within the dry core fill belong to the Early Classic. The second floor was about 12 cm thick. From this point, due to the presence of Feature 1 (in the northern half), the excavation continued only in the southern portion of the unit. Below this, Level 4, Lot 1 was

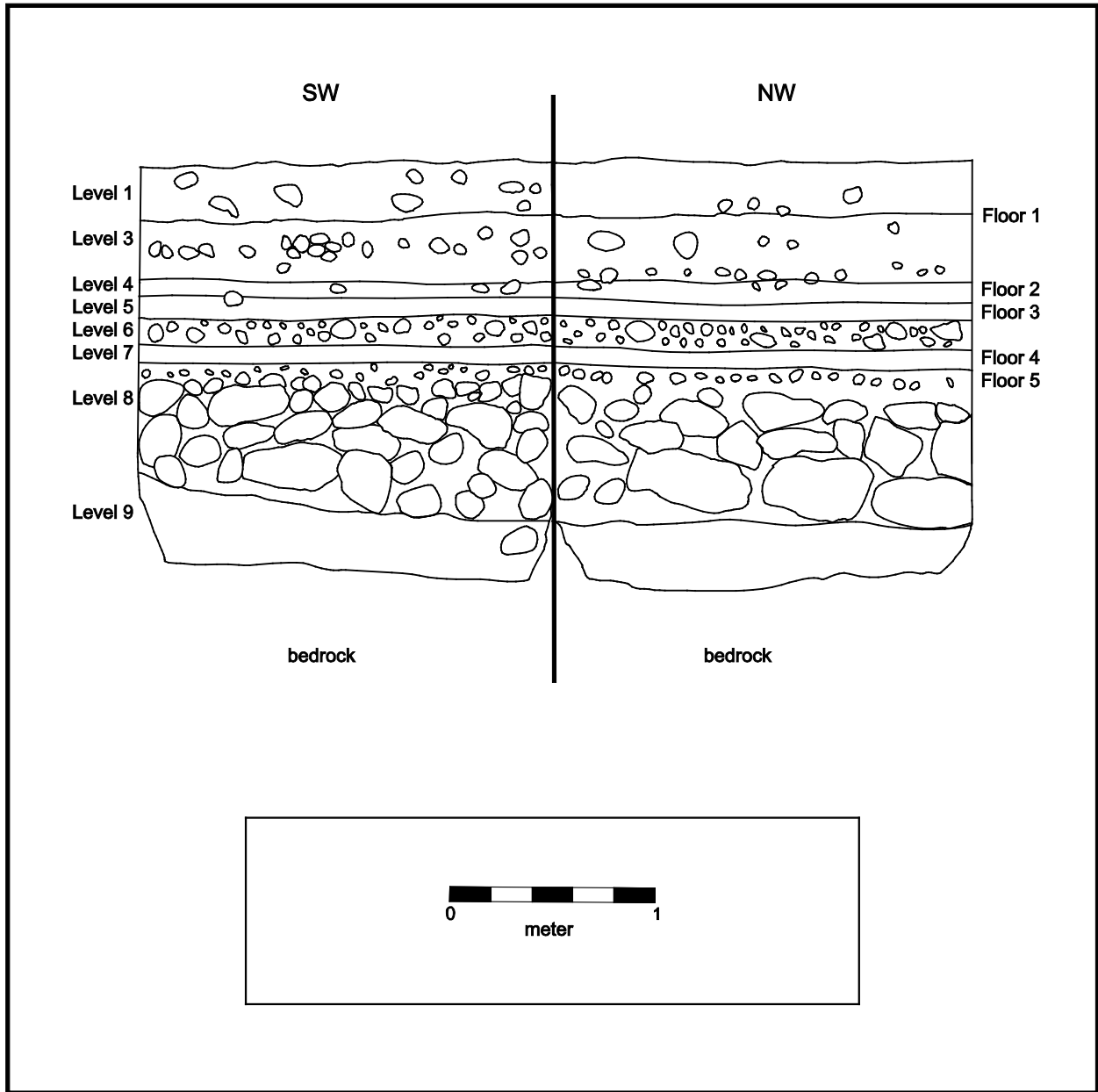

Figure 92. San Felipe, Operation 4, Southwest and Northwest Profiles

located, a layer of *chich* or gravel about 8 to 10 cm thick, with a brown color (7.5YR 5/4). The subfloor was followed by a third floor, or Level 5, Lot 1 (also brown 7.5YR 5/4). Both the subfloor of Floor 2, as well as the subfloor of Floor 3, appear to continue under the north half of the unit with the bench. Samples recovered in both floors, Floor 2 and Floor 3, were from Early Classic. Twelve cm below Floor 3, beneath a subfloor of *chich* and gravel, the presence of a fourth floor was revealed (Level 6, Lot 1). Unlike the previous surface, Floor 4 was pink in color (7.5YR 7/3) and about 7 cm thick. Based upon ceramic analysis, this level belongs to the Late Formative. The next level (Level 7, Lot 1) was the fifth floor, very similar in constitution and coloring to Floor 4. Once Floor 5 was removed, a medium-sized (about 30 cm thick) stone fill was found. It should be noted that this fill (Level 8, Lot 1) was not a "dry" fill, but was mixed with pinkish brown (7.5 YR 5/3) silt. Below this fill, a layer of redder soil (10 YR 3/4) was located, with a sandy consistency and whitish patches and clods of soil (Level 9, Lot 1). Ceramics obtained in the last three levels dated to the Late Formative. After removal of this layer, bedrock or *laja* was located, signaling the completion of the excavation (Figure 94).

Subsequently, proper registration, through photographs and drawings, was carried out. Furthermore, the platform or bench in the northern half of the unit (Feature 1) was consolidated. Once this operation was completed, it was backfilled to the original surface level.

Consolidation

Feature 1, the outer wall of a platform or bench was located in the northern half of the unit at Level 3. It was left *in situ* for further consolidation at the end of the excavation process. Said process began with the cleaning of the stones that formed the wall line of well cut stones and the inner surface of this platform or bench, and then proceeded with the replacement of the degraded mortar with a new mixture (made with 3 parts of lime, 3 parts of *sascab* (lime dust) and 1 part of white cement), in order to ensure its preservation and stability in the future. Once this process was completed, the necessary recording, through maps and photographs (Figure 95), was conducted. After the completion of this task, and before backfilling the unit, Feature 1 was protected with a line of middle-size stones and fine soil, in order to not damage it during the backfilling process.

Interpretation

The first occupation in the plaza, in the area of Operation 4, must have begun at sometime during the Early Classic period (in the case that the Terminal Classic ceramics come from the upper strata), but perhaps the site began to be inhabited, at least near the units, since the Late Formative period. Subsequently, at some point in this period, it was decided to create a raised plaza for which dry core fill of large stones (Level 8, Lot 1) was placed to form the base of Floor 5 (Level 7), which indicates the beginning of the formal development of this part of the settlement. This floor has a hole in the southeastern corner of the unit that appeared to be a post hole. Thus, we thought that perhaps in this area there was a perishable structure of some importance, because of its position in a central area of the settlement. Another possibility is that this area was not the central part of the settlement during the Formative period, and

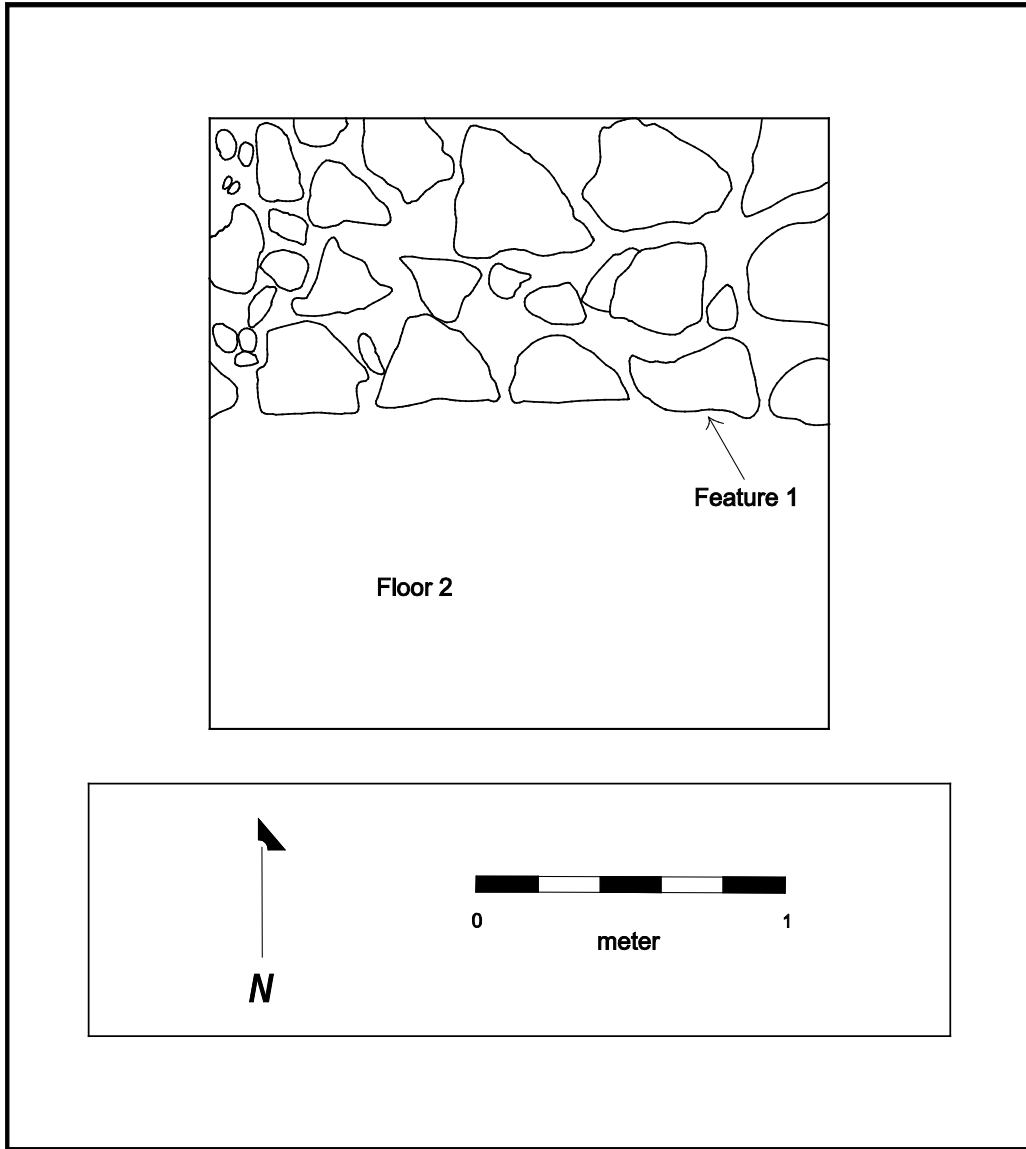

Figure 93. San Felipe, Operation 5, Level 3, Lots 1, 2 and 3

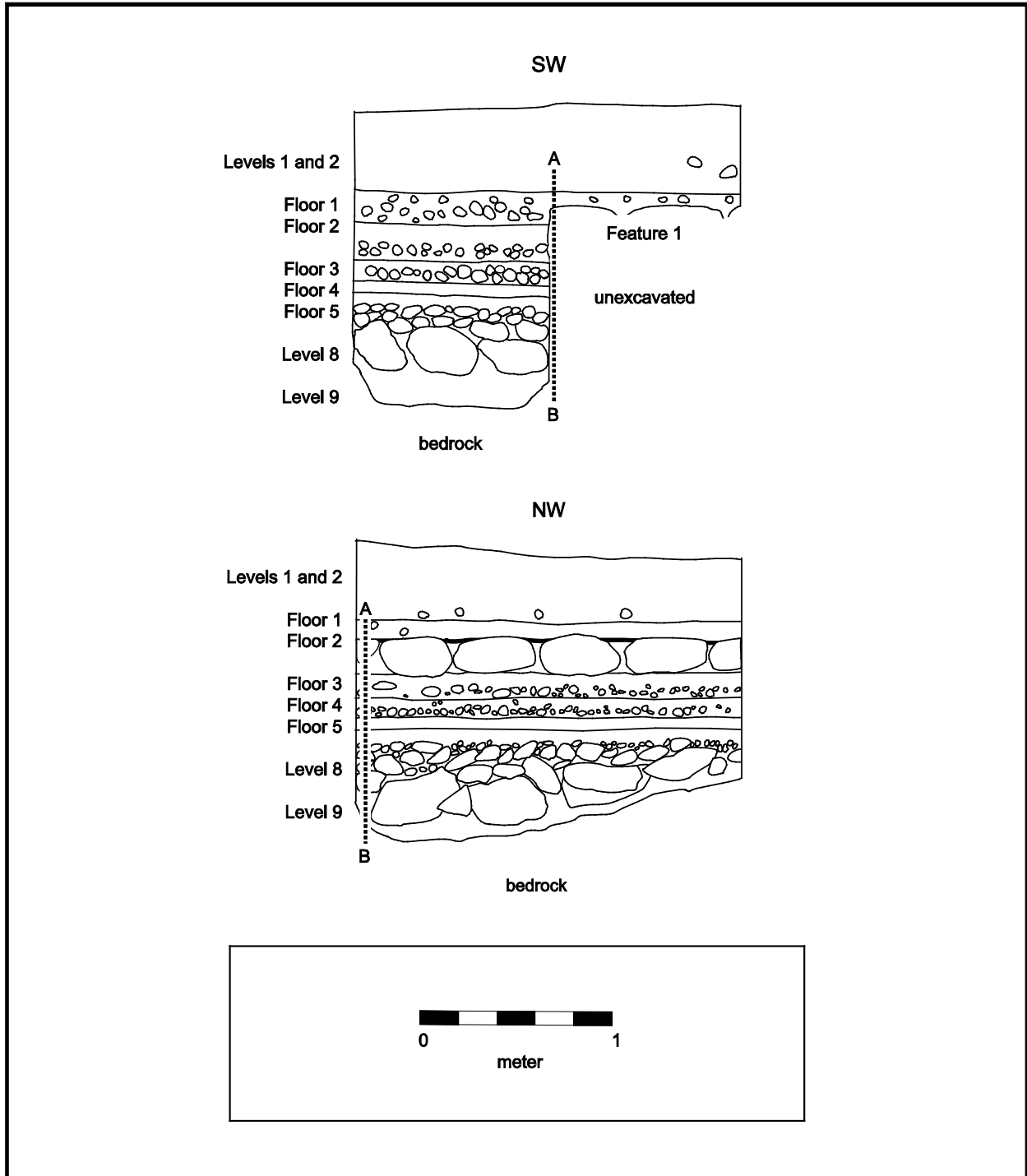

Figure 94. San Felipe, Operation 5, Southwest and Northeast Profiles

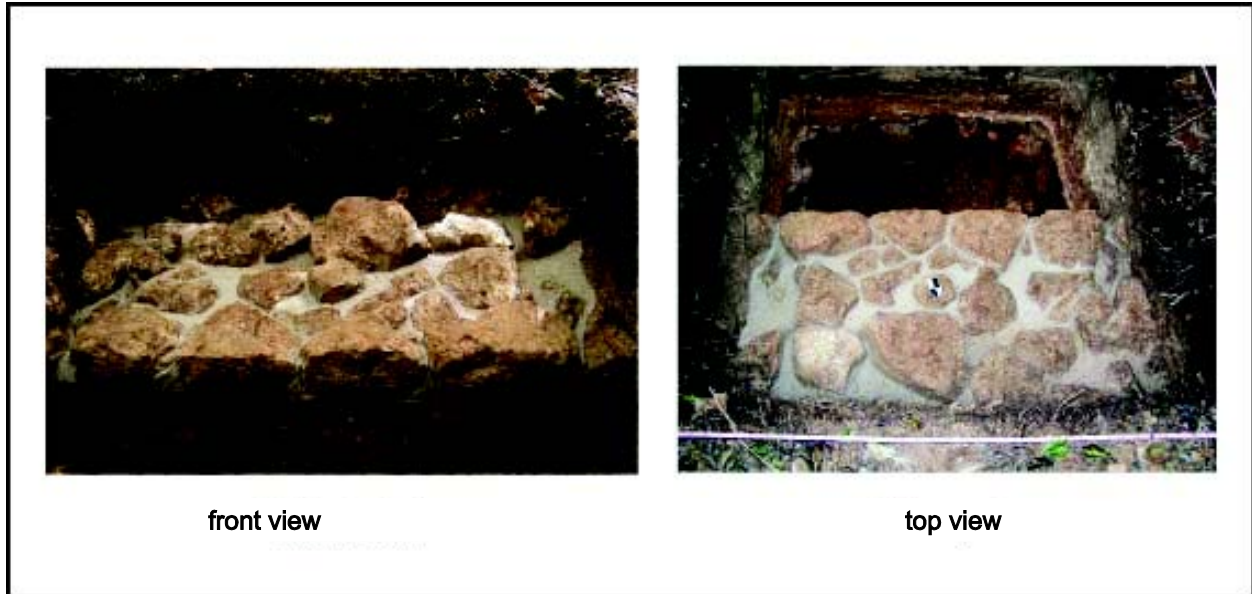

Figure 95. San Felipe, Operation 5, Feature 1, Consolidated

the post hole belongs to a peripheral structure. After Floor 5, Floor 4 and Floor 3, with their respective subfloors were constructed during Early Classic, as part of a new leveling of the plaza. Later, during the Terminal Classic, a new floor and plaza level (Floor 2) were constructed. Also during this period, another plaza leveling, Floor 1, took place, which we assume was the last plastered surface that this space had. Extreme degradation of this feature indicates that Floor 1 was exposed to the environment for a long period. It is curious to note that no Postclassic sherds were found in this part of the settlement. Although we assume that there was activity at the site during this late period (there are two Postclassic shrines a few meters from the unit), it could not have been intense, perhaps reduced only to occasional visits as part of the ancestral worship rituals. Postclassic residential occupation must have been located in other areas of the settlement. It seems that the Colonial/ historical population that inhabited this site prior to the Caste War was concentrated in the area where the modern village of San Felipe is now located, about 350 m southwest of the Prehispanic remains. It is likely that Postclassic occupation was in the same area of actual *pueblo*. After the last construction episode (of Floor 1), the area fell into disuse and Levels 1 and 2 were formed through the accumulation of natural processes.

The context of Operation 5 indicates that on the natural surface (Level 9, Lot 1), during Late Formative times, occupants began to build this part of the plaza by creating an artificial leveling, formed by stones (about 30 cm in size) and dirt fill, that were the basis for Level 5. Also in this period, another floor (Floor 4) was placed over the previous level (Floor 5), possibly as a work of maintenance over the surface of the plaza. In the Early Classic, there was a new leveling, of no great height, and a new floor (Floor 3) was constructed. Feature 1 was built over Floor 3; it was part of a low platform wall or a bench, which could have formed the northern side of the plaza during this period. This makes us suppose that either the place was open (bounded to the north, perhaps by Structure N4E5-1 and to the south by Structure N3E4-1) or this was a square that was divided by the placement of the structure including Feature 1 with the intention of creating an smaller and more private space. As part of the redevelopment of the plaza, a new plastered surface (Floor 2) was built, also covering the surface of Feature 1. Level 3, Lot 1 seems to have been the last plaza surface, which once covered the entire unit, including Feature 1, and has traces that it was exposed to weathering, as was discovered in a poorly preserved state. This suggests that the plan of this area was modified and the platform or bench was covered (Feature 1), perhaps to create more open and public space. All this may have occurred during Terminal Classic. Subsequently, this portion of the site fell into disuse and the last layers of the unit were formed by both the natural deposition (Level 1, Lot 1 and Level 2, Lot 1), as well as the collapse of Structure N4E4-2.

Although excavations at the site of San Felipe are still limited, these two test units have given us some ideas and new perspectives on this part of the settlement. In addition to showing the different periods of occupation, the results of these test units allow us to see signs of the changes that took place in this plaza through time. The above assumption could be tested in future by further excavations in this area. Although this is a minor advance, the results of the 2010 season have helped us to increase our knowledge of the past of this settlement, one of the better represented in this part of our study area.

Part 4: The *Ejido* of San Felipe

Chapter 35: San Lorenzo, Operation 1

Alberto G. Flores Colin

The Prehispanic site of San Lorenzo was documented by the Project in 2008, a season during which a first reconnaissance of its surface features and its surroundings was conducted, as well as a topographic plan of its main features. This season, in order to complete a basic documentation, a series of test pits in various areas were proposed to get a better understanding of the site and construct a temporal sequence.

Operation 1 was placed in the main raised plaza of the site, bordered by eight structures of different heights (Figure 96), at the foot of Structure S1E1-3, a 4-m-high range structure located at the southeast portion of the site, near a small Postclassic shrine, Structure S1E1-8. This 2 x 2 m unit had six stratigraphic levels. Level 1, Lot 1 corresponded to a layer of brown (2.5Y 4/2) soil, mixed with organic material (roots and dead leaves from secondary vegetation) and a few small-to-medium-size stones (about 5 cm and 15 x 7 x 20 cm), which lay without any apparent order. Some ceramic fragments indicate that this level belongs to the Postclassic period, as evidenced by Chen Mul Modeled ceramic type. The thickness of the layer was about 15 cm, and below it another strata lighter in color (2.5Y 6/3) was found, designated as Level 2, Lot 1. Pottery found in the level was from Terminal Classic period, mainly Yokat Striated and Muna Slate. The removal of Level 2 revealed the presence of a series of stones that were positioned at the same level, a pavement that entirely covered the unit (Figure 97) but not too concentrated, as it was interspersed with a brown soil (2.5Y 5/3). This level (Level 3, Lot 1) was about 20 cm thick; within it a few Terminal Classic sherds were discovered. Beneath this layer, a brown soil deposit, lighter than before (2.5Y 5/4), was located; it was also mixed with some stones of about 15 x 20 cm on average. Sherds located within this level allow us to date it to the Terminal Classic (Yokat Striated and Muna Slate). The complete removal of the layer revealed the presence of another stone level, this time in greater numbers, so the level was changed to Level 4, Lot 1. The deposit consisted of a stone fill of different sizes that was about 1.5 m thick on average, mixed with a reddish soil (2.5YR 4/6). No sherds were found in the level. Although in some parts of the unit the fill was "dry," in other words without mortar, most of the stones were mixed with the above mentioned reddish sediment. Once this level of fill was totally removed, a next layer of a red clayey soil was found, locally known as *chac luum* (lit. in Maya "red soil", 2.5YR 5/6), which contained few large stones, but without any apparent order. Level 6, Lot 1 also could be assigned to the Terminal Classic, due to the presence of fragments of Yokat Striated and Muna Slate types. The end of this stratum was marked by the discovery of the bedrock or *laja*, which also marked the final of the excavation process (Figure 98). After proper recording, we proceeded to backfill the unit to its original level before our intervention.

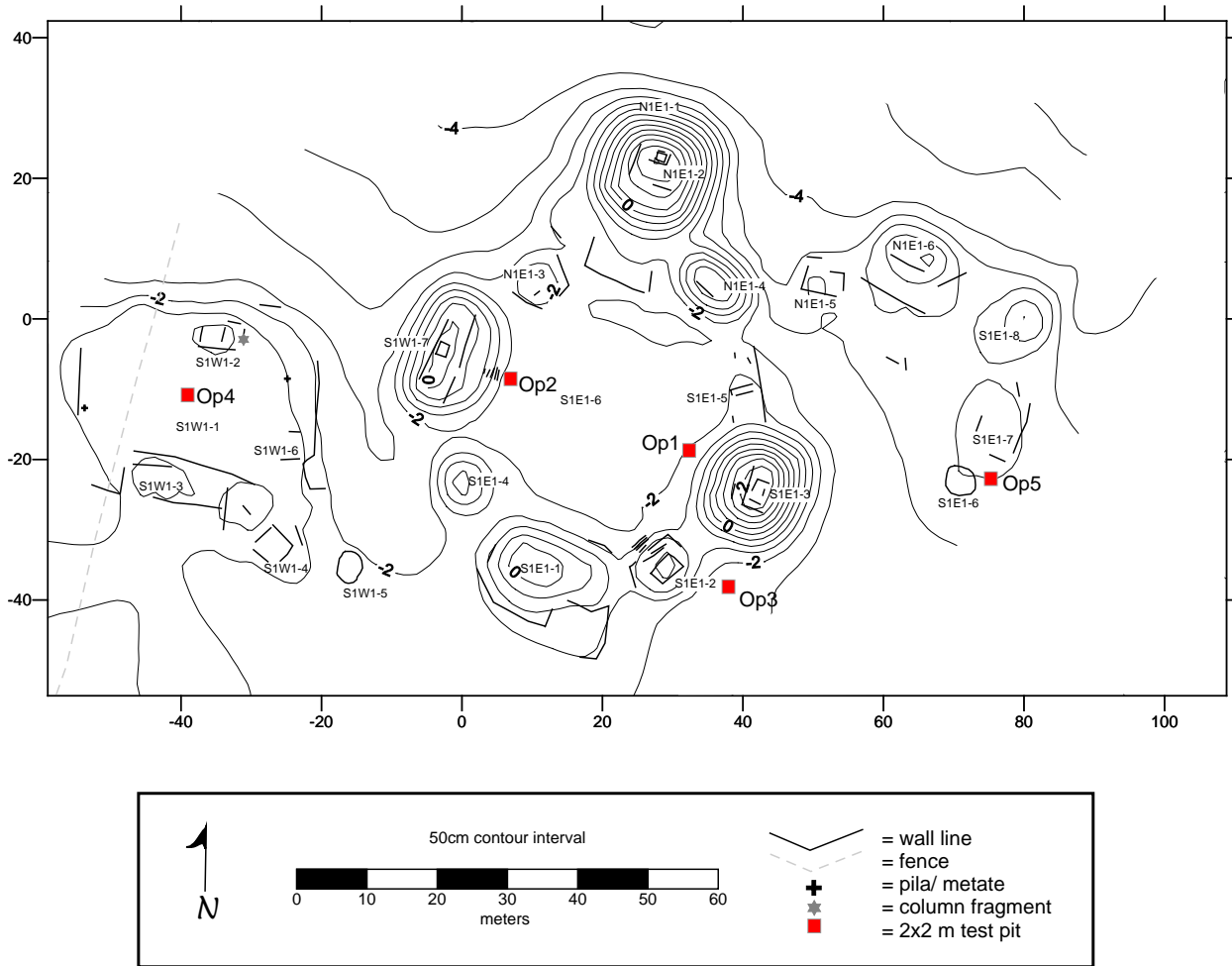

Figure 96. Location of Excavations at San Lorenzo, San Felipe

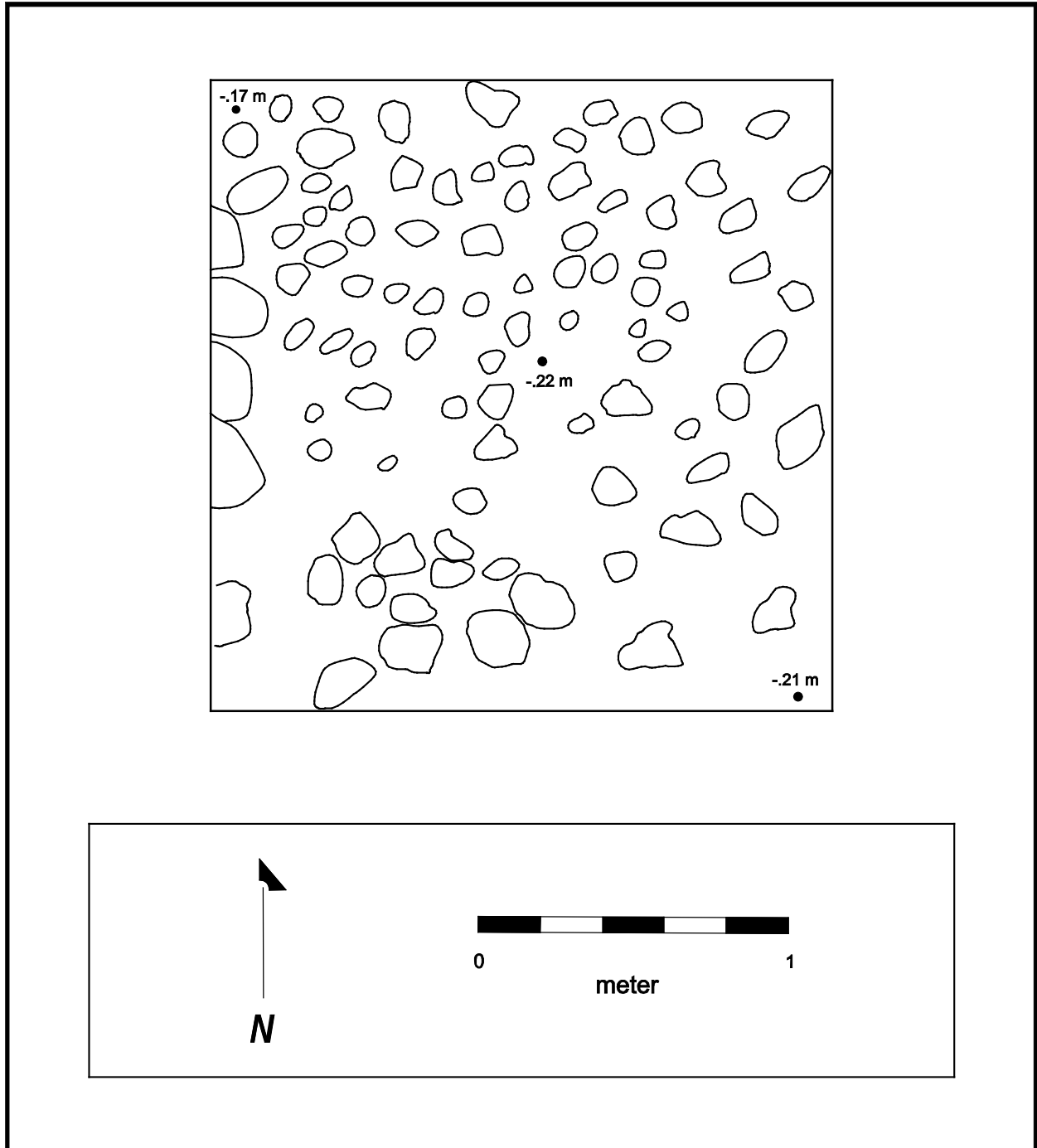

Figure 97. San Lorenzo, Operation 1, Level 3, Lot 1

Interpretation

According with the data obtained from this test unit, we can conclude the following sequence for this part of the site of San Lorenzo. It seems that this site did not have any significant occupation until the Terminal Classic, when there was only the natural surface, formed by the reddish soil or *chac luum* (Level 6). At some point, also in the Terminal Classic period, it was decided to raise the plaza 1.5 m above the natural terrain (Level 5); this fill could have included a plastered surface or plaza floor as its cap. After that, also during the same period, there was a lack of maintenance that implies that the proposed plastered surface of this plaza was degraded and was covered by a light brown sediment (Level 4). The next level (Level 3) corresponded to a cobbled surface that formed a new plaza, perhaps also stuccoed. This, according to the sherds obtained, also occurred during or after the Terminal Classic. If there was a plastered surface, it should be within Level 2, but is now degraded and perhaps this caused the light brown color that shows this stratum. Sherds found within this level have allowed us to associate it, along with the previous level, to the Terminal Classic, since both formed part of the same construction process. It is probable that this pavement is also associated with the Postclassic shrine (Structure S1E1-8) to the southwest of the unit, potentially constructed when the site was already abandoned or disused. Level 1 is only the accumulation of sediment over all the time that the site has been abandoned, formed by collapse and decaying organic material. Ceramic fragments indicate that this began during the Postclassic. The information about this unit should be supplemented by, and compared with, San Lorenzo's Operation 2 (see Chapter 36 this volume) for an interpretation or hypothesis about the processes that occurred in this part of the site of San Lorenzo. Future excavations and research will help us to better understand this sprawling settlement.

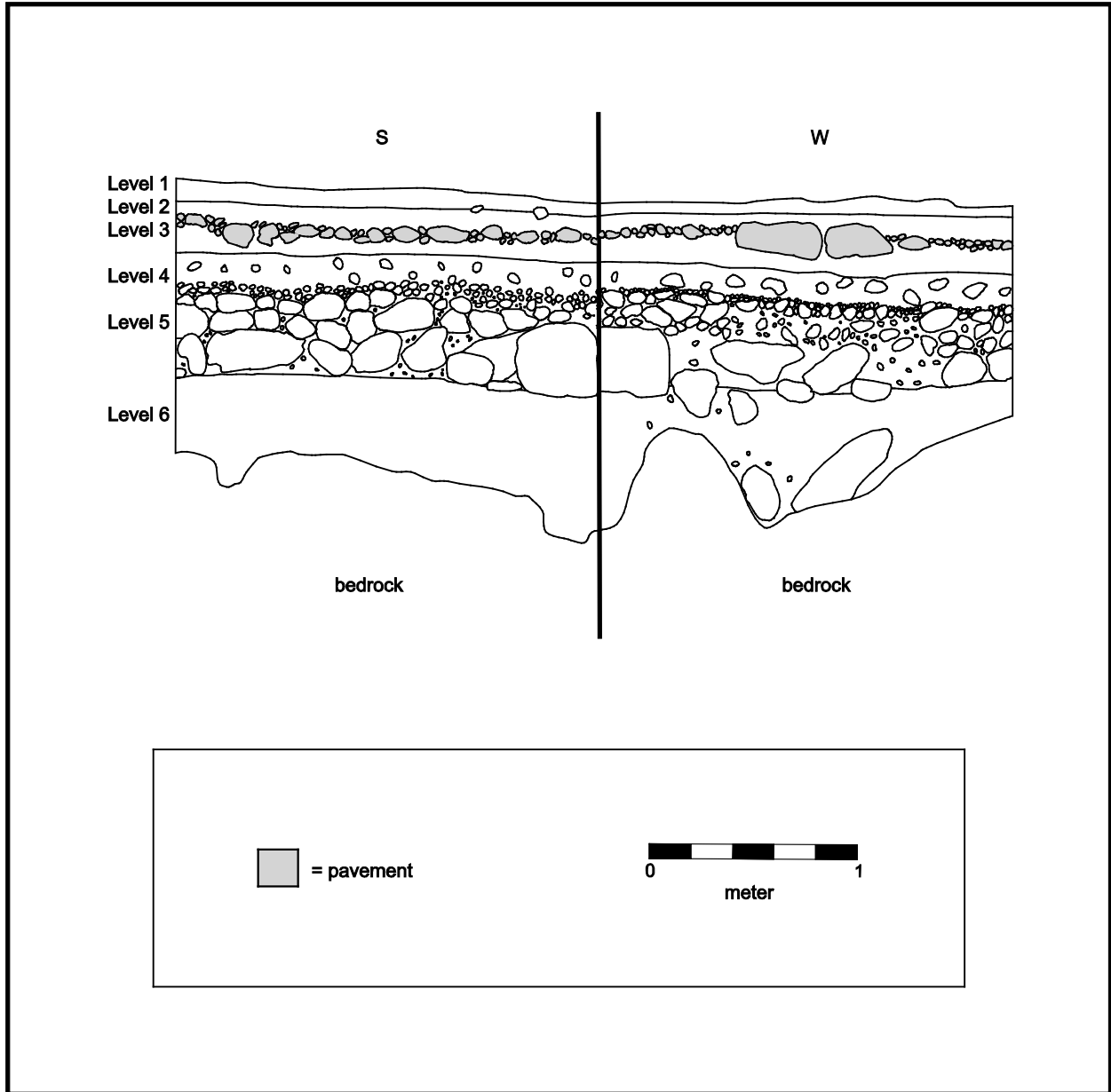

Figure 98. San Lorenzo, Operation 1, South and West Profiles

Part 4: The *Ejido* of San Felipe

Chapter 36: San Lorenzo, Operation 2

Justine M. Shaw, Thania E. Ibarra Narváez and Alberto G. Flores Colin

Operation 2 at San Lorenzo was a 2 x 2 m test pit located on the main plaza of the site, to the east of one of the structures that defines the plaza (Structure S1W1-7). This operation was divided into five levels. The first level of the operation was an arbitrary level of 10 cm. In this level, few ceramics were located, and it was composed entirely of soil without stones. The soil was reddish brown. Among the ceramic material located in this layer, it was possible to identify the Yokat Striated and Muna Slate (from the Terminal Classic), but we also found a few Postclassic sherds. The next level was also an arbitrary level of 10 cm, which consisted only of soil without stones but with some sherds. The color of the soil was reddish brown and the ceramic material belongs to the Terminal Classic (Yokat Striated) furthermore two Postclassic ceramic fragments (Figure 99).

After these two arbitrary levels, formed entirely by sediment, a pavement surface was located. Since this pavement was not present across the entire unit, it was decided to divide it into two lots. Level 3, Lot 1 is where the pavement was present, formed by rocks of about 4 to 7 cm. The soil color of the lot was brown; ceramics were identified to the Terminal Classic, as well as from the Early Classic and Middle Formative. This indicates that the pavement was completed during the Terminal Classic, since the pottery dated to that period is underneath and above this cultural layer. Middle Formative ceramics were only found underneath, while the Postclassic examples are above the pavement.

Level 3, Lot 2 is where the pavement is absent. Although there were a few small stones, it is unclear if these are part of the paving, due its poor state of preservation (Figure 100). Soil in the lot was brown and the ceramics date to the Middle Formative through Terminal Classic.

Level 4 was also divided into two lots. It was construction fill, being composed of a "dry" fill (without mortar) in one section, while the other was a soil fill without rocks. Level 4, Lot 1, as has been mentioned, consisted of a dry fill that lay immediately below the pavement; a small quantity of dark reddish brown soil was found. In addition, a significant ceramic sample, mostly Dzudzuquil Cream to Buff from the Middle Formative, as well as examples of Late Formative sherds, was found. Therefore, this fill must have been constructed with rubble of that period, probably from a midden or from a nearby structure that was modified. In Level 4 Lot 2, the northwest corner of the unit, the absence of rock fill was noticed. In addition, this lot coincides with the absence of paving that was detected in the previous level. Within the lot was a spherical ceramic pot, of 10 cm in diameter at the mouth and 16 cm at its widest point (Figure 101).



West Profile

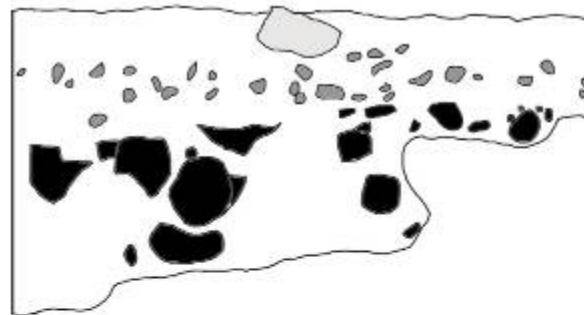

North Profile

Figure 99. San Lorenzo, Operation 2, West (above) and North (below) Profiles

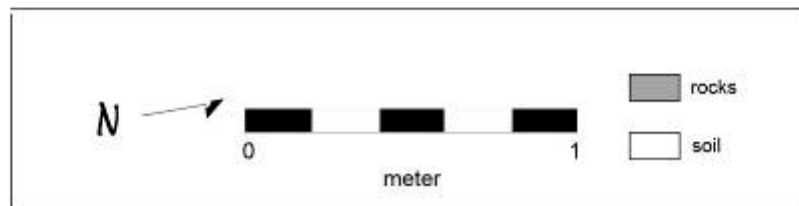
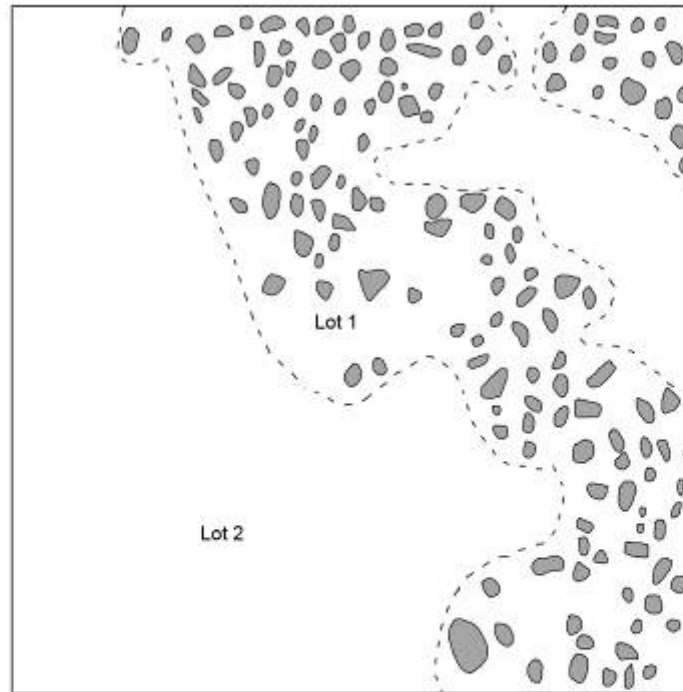

Figure 100. San Lorenzo, Operation 2, Level 3, Plan Map



Figure 101. Pot, San Lorenzo, Operation 2, Level 4, Lot 2

Around the pot, three large stones were found. The pot was subject of a micro-excavation process, the result of which was that it contained nothing inside, only a few sherds of what may have been a plate that perhaps served to cover it. The type of this ceramic pot is Chum Unslipped Chum and the plate is Muna Slate, both from the Terminal Classic. According to the ceramic analysis, the lot where the pot was located is later in time than the stone fill, but, with being both at the same depth, it can be concluded that Level 4, Lot 2 must be some kind of intrusion, probably a hole that was made after the pavement was completed in order to place the pot as an offering. Perhaps it is part of another latter occupation in the site. The intrusion can be confirmed since the immediate surface above the pavement dates to the Terminal Classic, the same time period as the pot and the ceramic plate. In addition to Level 4, Lot 2, in what was designated as Level 3, Lot 2, there are no remains of pavement.

After removing the construction fill and the ceramic pot a final level was found, a layer of red soil or *chac luum*, Level 5, Lot 1. This last level of the unit consisted of red soil without stones, but with some sherds. Ceramics in the deposit included Dzudzuquil Cream to Buff (from Middle Formative), as well as several examples of Late Formative sherds. After removing the level, bedrock was reached. At the end of the operation, having fully documented the four profiles, we noted that in the south and west profiles has some sections of a dry fill, while in the north and east profiles a normal soil fill was observed. It is probable that this difference was caused by the intrusion, or perhaps by a construction technique that was used, or that these different deposits belong to different times.

Part 4: The *Ejido* of San Felipe

Chapter 37. San Lorenzo, Operation 3

Alberto G. Flores Colin

The Prehispanic settlement of San Lorenzo was studied in 2008 by the CRAS Project. During that season, reconnaissance and a topographical registration of its surface were conducted. With the data from this first visit to the settlement, we decided to perform a series of operations or test units to get a better understanding of some of the site's basic aspects, such as the timing of the different areas within the site. With these aims, we planned the excavation of five test pits for the 2010 season (Figure 96).

Operation 3 was located outside the main plaza of the site, south of the corner formed by the Structure S1E1-1 and S1E1-2, southeast of the main complex. This unit was a 2 x 2 m test pit, and consisted of seven levels. Level 1, Lot 1 was a blackish layer (10YR 4/3), mixed with a series of stones located mainly to the north side of the unit, without any apparent arrangement. According to the sherds that were located, this level relates to the Terminal Classic. Due to its proximity to Structures S1E1-1 and S1E1-2, and generally with the main plaza of the settlement, it is likely that these stones may have collapsed from one or more of these buildings. For this reason, we decided to change to Level 2, Lot 1, which was a layer of brown soil (10YR 4/3) mixed with a few small stones (5 x 7 cm); furthermore, several collapsed stones were located in the north portion of the operation. Ceramics found within the level allow us to date the deposit to the Terminal Classic period. Beneath this layer, a reddish soil (2.5YR 4/6) was located, designated as Level 3, Lot 1. The layer also included several stones from the collapse, largely located in the northeastern part of the unit while in the remainder only a few pebbles (about 10 x 15 cm) could be found, without any apparent order but at the same level. Sherds located within the deposit, belonging to Yokat Striated and Muna Slate types, indicate a Terminal Classic date. The next level located was Level 4, Lot 1. This consisted of a small stone bed that covered almost the entire unit, with the exception of some sections located to the south (Figure 102), and was mixed with red soil (2.5YR 4/6). Ceramic types, Yokat Striated and Muna Slate, allow us to assign this level a Terminal Classic date. Once the layer was removed, a shift to a more reddish soil (2.5YR 2/4) was discovered; it contained a series of whitish spots, plus a few stones of about 10 x 7 cm. Level 5, Lot 1 was very compacted. Ceramics found within the level indicate that the level dates to the Late Formative, as evidenced by samples of the Sierra Red type. Following this stratum was Level 6, Lot 1, a layer of a whitish red soil (2.5YR 5/8). This was mixed with lots of stones of about 10 x 8 cm on average, although it also contained some smaller ones, which appeared to be part of eroded bedrock, since they possessed a very smooth or polished form,

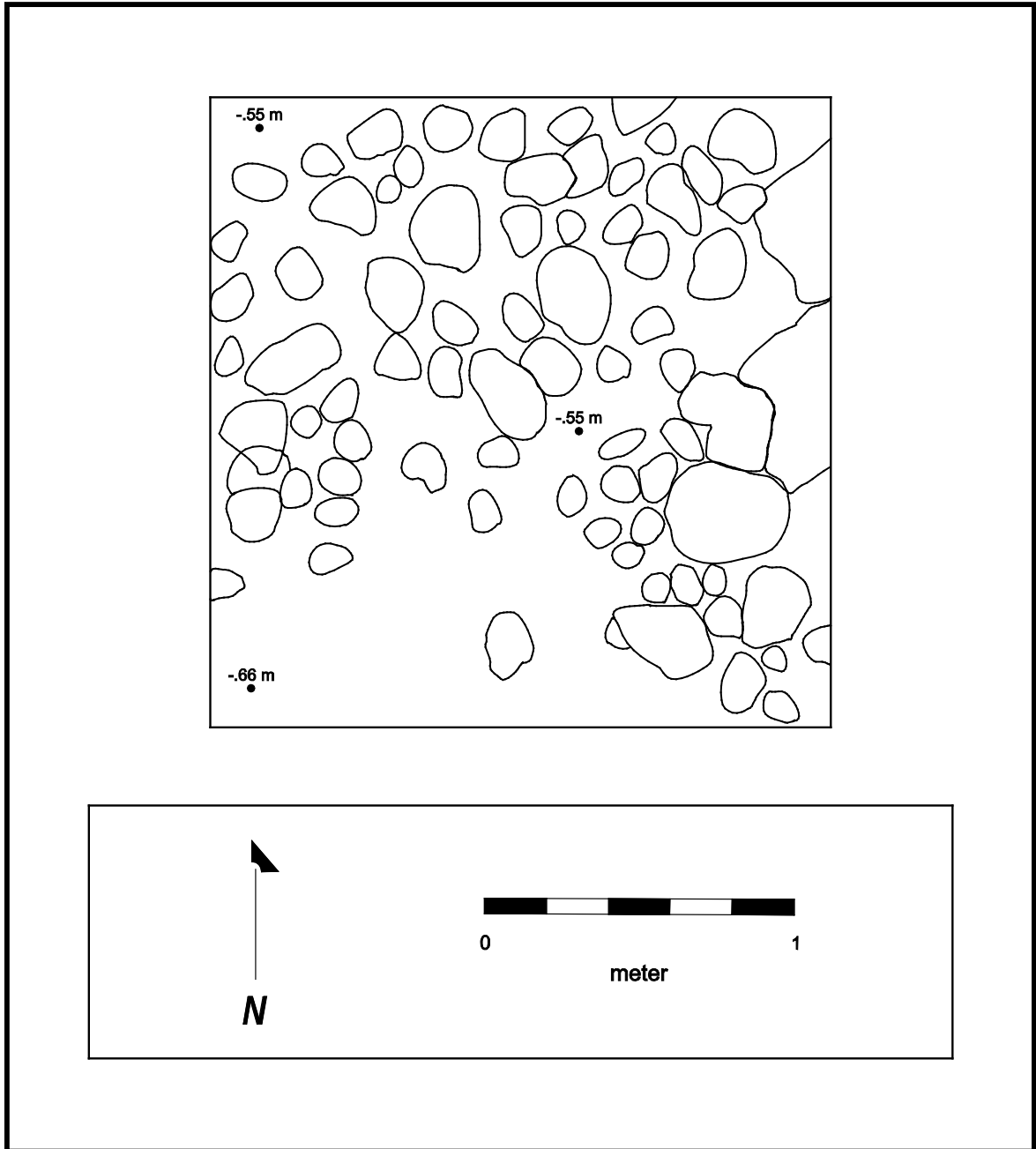

Figure 102. San Lorenzo, Operation 3, Level 4, Lot 1

showing water filtration. Although most of the sherds in the level belong to the Late Formative period, a Terminal Classic fragment was also found, which dates to later times. However, the fragment may have been accidentally mixed during excavation. Level 7, Lot 1 consisted of a layer of pebbles very similar to that of the previous level, composed by small boulders, but this time with much less sediment. It was also more compacted, so it was separated to another level, although its color was the same as the previous level (2.5YR 5/8). In the western part of the unit, a rocky section was discovered that descended vertically to the east of the pit. This level was excavated for 50 cm more. It was a sterile level, except for a few sherds that were found very close to the beginning (Sierra Red), so the level was dated to the Late Formative. The sediment comprising the level had some white patches, which are due to degradation of small limestone pebbles, as these patches had the same shape of the stones that covered them that were removed during the excavation process. Due to time constraints, and considering the fact that the last 40 cm of the unit were sterile and the possibility that the covered section of the bedrock was much deeper, excavation was completed and registered at this level (Figure 103). Once these tasks were concluded, the test pit was backfilled with the same material that was removed, until the original level before our intervention.

Interpretation

Levels 7, 6, and 5 correspond to the natural ground surface, which may have been the floor for the first settlers of this site. Sherds from these levels were from the Late Formative, so we can assume that the occupation at this time was low in density, perhaps reduced to a few people who used perishable buildings with no other more permanent materials involved, such as rocks or mortar that would be left evidence. We assume that during this time, at the site of San Lorenzo, changes and modifications were minor, and perhaps the main plaza did not exist, at least not in the form that it has today. On top of these levels, we found a small stone pavement (Level 4, Lot 1), which did not seem to be the base of a *sascab* floor, but rather resembled the surfaces that are placed outside the doors of some traditional Maya houses in modern times, in order to protect the doors from being flooded. Because this unit is outside of the main plaza, in addition to the evidence located during the excavation, is also likely that there existed a stucco surface and this pavement (Level 4) has been its base. If this was true, the stucco surface should have existed within Level 3, Lot 1, which was also dated to the Terminal Classic. Level 2, Lot 1 and Level 1, Lot 1 are formed by the accumulation of sediment since the site was abandoned until today, as well as the collapse of Structures S1E1-1, S1E1-2 and S1E1-3 and the main plaza. According to the survey conducted in 2008, there does not appear to be monumental architecture to the southeast of the main plaza, but only a few foundations braces were located. Therefore, we do not think that there was a formal plaza in the southeast area, but perhaps it had a *sasbab* floor or some other surface. No material or architectural evidence from the Postclassic was located in the vicinity of this operation, but an occupation of this period is evident in other areas of the settlement. Future seasons' investigations will help us to get a better understanding of the area and, in general, of the site of San Lorenzo.

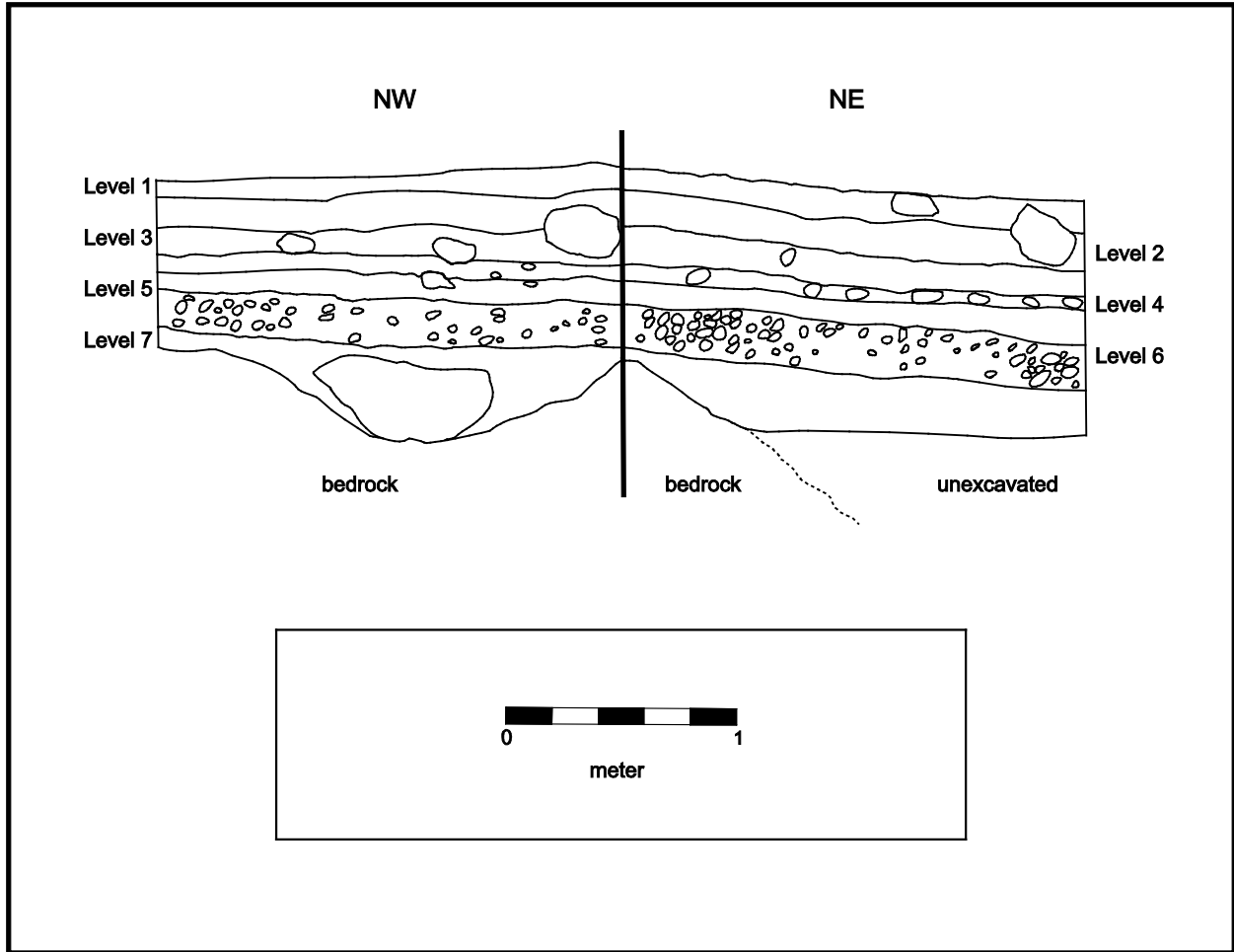

Figure 103. San Lorenzo, Operation 3, Northwest and Northeast Profiles

Part 4: The *Ejido* of San Felipe

Chapter 38: San Lorenzo, Operation 4

Alberto G. Flores Colin

San Lorenzo was topographically recorded in 2008. As part of CRAS Project, this year included the excavation of a series of test units to better understand the settlement (Figure 96).

Operation 4 was located in an artificial leveling attached to a limestone outcrop, which formed a sort of plaza that houses the Structures S1W1-1, S1W1-2, S1W1-3, and S1W1-6, and has been called Plaza B.

This unit was a 2x 2 m test pit and included seven levels. The first level, Level 1, Lot 1, consisted of a layer of dark brown (7.5YR 3/2) soil and a few pebbles. In this layer, we found a large quantity of ceramics, through which we can date the level to the Terminal Classic, as evidenced by the dominance of Yokat Striated and Muna Slate ceramic types. Level 2, Lot 1 consisted of a layer of brown soil (10YR 4/3), mixed with stones of various sizes, ranging from large (60 x 70 cm) to small (7 x 10 cm). These stones lay with no apparent order, but did not cover the entire unit; instead, they were concentrated in the middle of the unit. Ceramically, the level also belongs to Terminal Classic. It concluded with the discovery of a series of medium-sized stones (20 x 20 cm), located eastern portion of the unit that were mixed with a brown and highly compacted sediment (10YR 4/3). The western area had the same soil but it was mixed with small gravel (5 x 7 cm). Therefore, the level was divided into two lots. Level 3, Lot 1 corresponded to the area with the larger stones, to the east, while Level 3, Lot 2 was to the west and had the gravel or small stones (Figure 104). Sherds removed from both lots are from the Terminal Classic. The removal of the previous level led to the discovery of another layer of brown soil (10YR 5/4), lighter than the previous level, but mixed with the tops of large stones (40 x 60 cm). Thus, it was decided to change to the following level (Level 4, Lot 1). These stones were part of construction fill that was about 40 cm thick, which was not "dry," but instead lay mixed with the brown sediment described above. Like the previous levels, it also contained Terminal Classic ceramics. Beneath this level, a brown soil layer (Level 5, Lot 1) was found. It was a little darker (10YR 3/3) than the previous deposit, mainly composed of sediment; only a few stones were found in the layer. The level belongs to the Early Classic, as evidenced by sherds of the Xanaba Red type. The next level, Level 6, Lot 1, was a layer of grayish clay soil, of about 10 to 15 cm thick, while Level 7, Lot 1 consisted of a red sediment (2.5YR 4/6), locally known as *chac luum*. The excavation of this level ended with the discovery of a bedrock section in the southern part of the unit, while in the northern half the red color sediment became more whitish (2.5YR 5/3). However, northern part continued under excavation as Level 8. The pottery collected within Level 6 allowed us to assign a date of the Early Classic, while those in Level 7 pertain to the Late Formative period. The last layer of the unit was divided into two lots, Level 8, Lot 1 for a patch of gray soil and

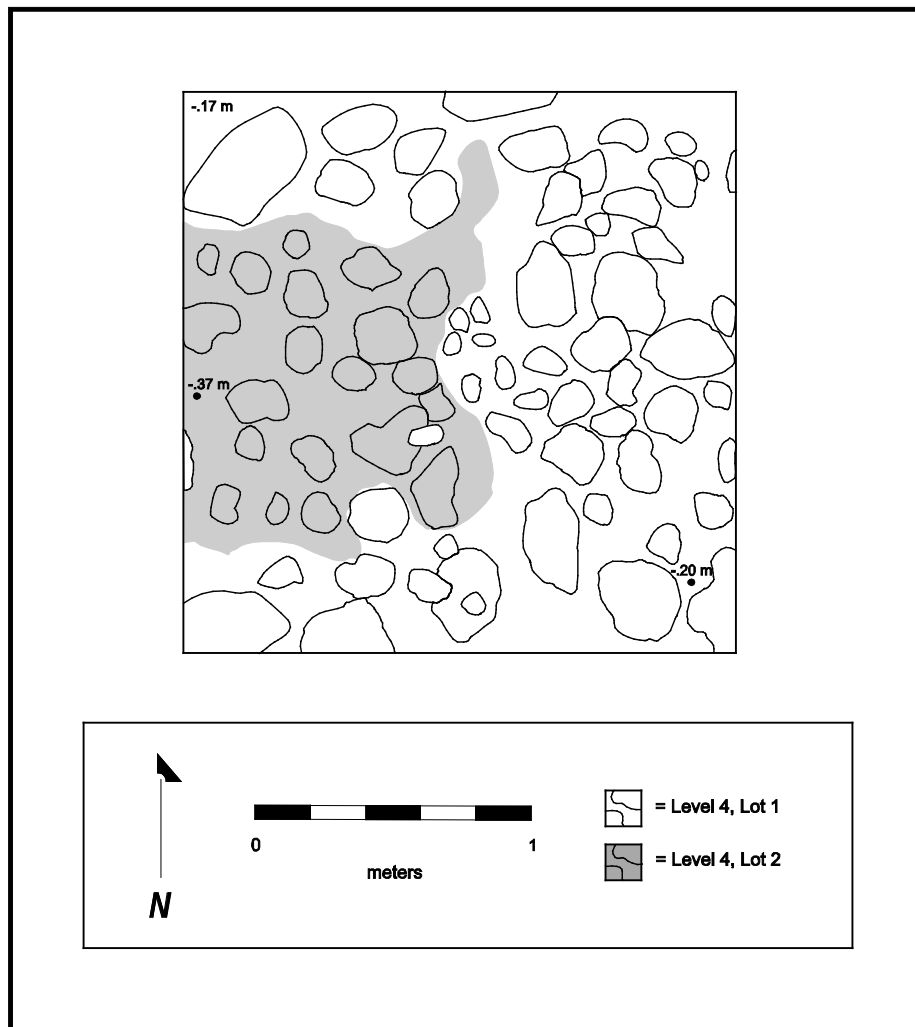

Figure 104. San Lorenzo, Operation 4, Level 3, Lots 1 and 2

Level 8, Lot 2 for the rest of red soil. Ceramically, Level 8, Lot 1 had Early Classic sherds; Level 8, Lot 1 contained only fragments from Formative times, both the Middle and Late periods, being the oldest sample from the settlement. After completing the task of registration (Figure 105), the unit was backfilled to its original level.

Interpretation

This unit was interesting due to the presence of abundant Formative ceramics in its early stages. Although the material is within a tertiary context, since it seems that it was part of construction fill, we can assume that there was an occupation of this period in the vicinity. Levels 8 and 7 correspond to the first level of the Formative, which was composed of soil and stones. Level 8, Lot 1, which contained Early Classic ceramics, seems to be an intrusion, perhaps a hole created by burying a post or some other type of excavation. Its shape was poorly defined, but the difference was clear in the sediment's surface. Levels 6, 5, and 4 together compose another construction event, which must have happened during Early Classic. Level 5, the construction fill of stones and sediment, was the basis for a probable surface, perhaps plastered and now degraded, that lay in what we discovered and named as Level 4. Later, in the Terminal Classic, was a new leveling (including Levels 3, Lot 1 and 2), which consisted of a pavement made of small- and medium-sized stones. It was probably the base for the last plaza surface that we could identify, which must have been within Level 2, although the latter was also mixed with the material accumulated after the site fell into disuse or abandonment. It was likely a plaza surface around which the structures comprising the complex were situated, although it is also possible that it belongs to later times. Equally, Level 1, Lot 1 consisted of the sediment from after the site went into disuse or lacked support, but it also presented high concentrations of organic material. Although the information collected on this unit is scarce and inconclusive, the ceramics obtained have left more questions than answers, mainly due to the great age of the material that was discovered in its earlier and deeper levels. Evidence of the architecture that surrounds this small square appears to be from the Postclassic or Terminal Classic, and those are only a series of foundation braces. There is no surface evidence of earlier occupations' structures. Thus, the findings of this test unit prompt us to continue with more excavations at the site in the future to determine what other areas may have Formative phases. Future investigations would help us resolve these issues.

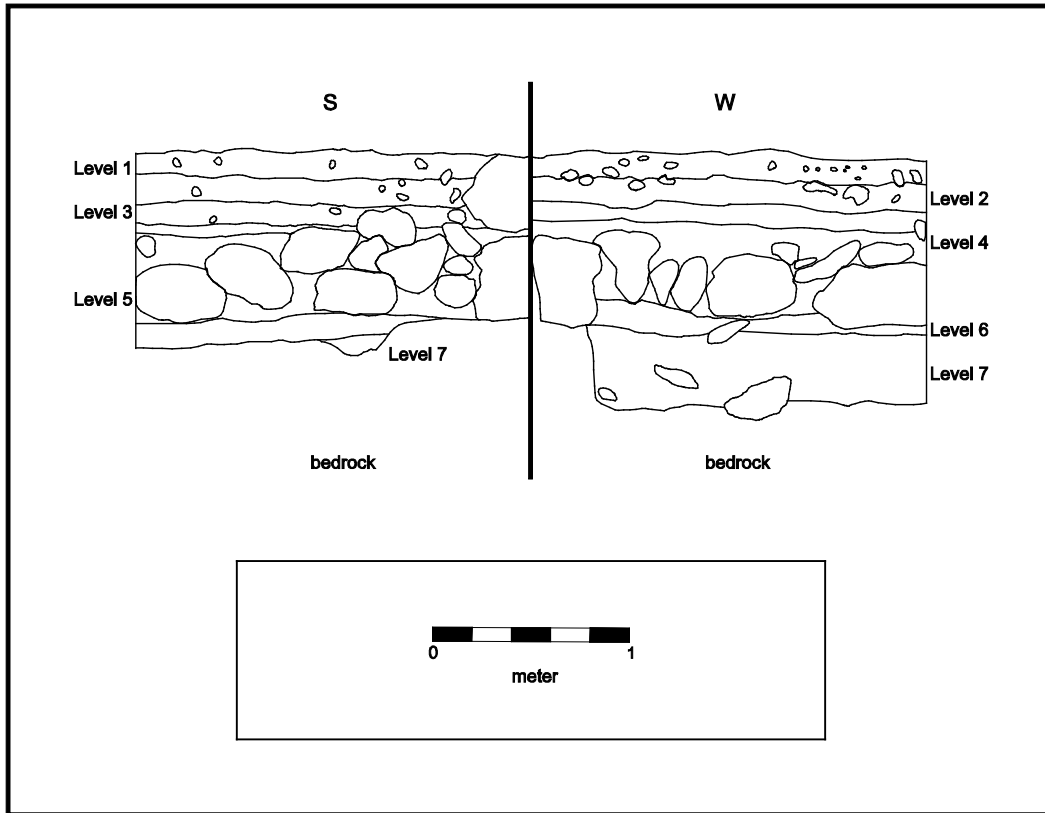

Figure 105. San Lorenzo, Operation 4, South and West Profiles

Part 4: The *Ejido* of San Felipe

Chapter 39: San Lorenzo, Operation 5

Alberto G. Flores Colin

The settlement of San Lorenzo was recorded by the CRAS Project since 2008. As part of continuing investigation in the *ejido* of San Felipe, it was decided to conduct a series of test pits to investigate the possible temporality of the site and, generally, have a better understanding of the history of this settlement.

Operation 5 was a 2 x 2 m test pit, located near Structures S1E1-6 and S1E1-7. The former is low platform, while the latter is a circular foundation base, which may date to the Postclassic; both are located east, and outside, of the main plaza (Figure 96). Although the terrain where the unit was located appears to be natural or little modified, it was thought that this area could be a sort of adjacent plaza, formed by the back of Structure S1E1-3, as well as Structure N1E1-5, N1E1-6, N1E1-7 and N1E1-8 and perhaps it had a plastered surface. This hypothesis may be compared with the results of the excavation.

Level 1, Lot 1 was a blackish red layer (2.5YR 3/3), mixed with a few stones, that was 20 cm thick on average. The date of the layer corresponds to the Terminal Classic period. Beneath this deposit, what appeared to be an occupational area was found, which could be seen as a series of stones with no apparent order mixed with a reddish brown sediment (2.5YR 4/4), that had a greater compaction than the sediment excavated previously. Removing the layer resulted in the discovery of a large number of stones that could be part of a pavement (Level 2, Lot 1). Pottery located within the level is also from the Terminal Classic, evidenced by Yokat Striated and Muna Slate types. The excavation of the second level culminated with the finding of a red layer (2.5YR 5/6), which was divided into two lots, because the central section of the unit had a very loose and smooth soil. Level 3, Lot 1 was assigned to the central area that appeared to be a post hole or some other intrusion that had left the sediment much less compacted than the other parts of the unit. Level 3, Lot 2 corresponded to the rest of the test pit. There were a few stones located in the southwestern portion of the unit; these lay without any apparent order and their origin seems to be natural. Some sherds from Level 3, Lot 1 were identified as the Sierra Red ceramic type, from the Late Formative, while Level 3, Lot 2 had mainly Terminal Classic sherds (Yokat Striated and Muna Slate). Both lots were completed at the bedrock or *laja*, thus finished the excavation of the operation (Figure 106). After the appropriate registration (photographs and drawings), the excavation was filled up to its original level, as it was prior to our intervention.

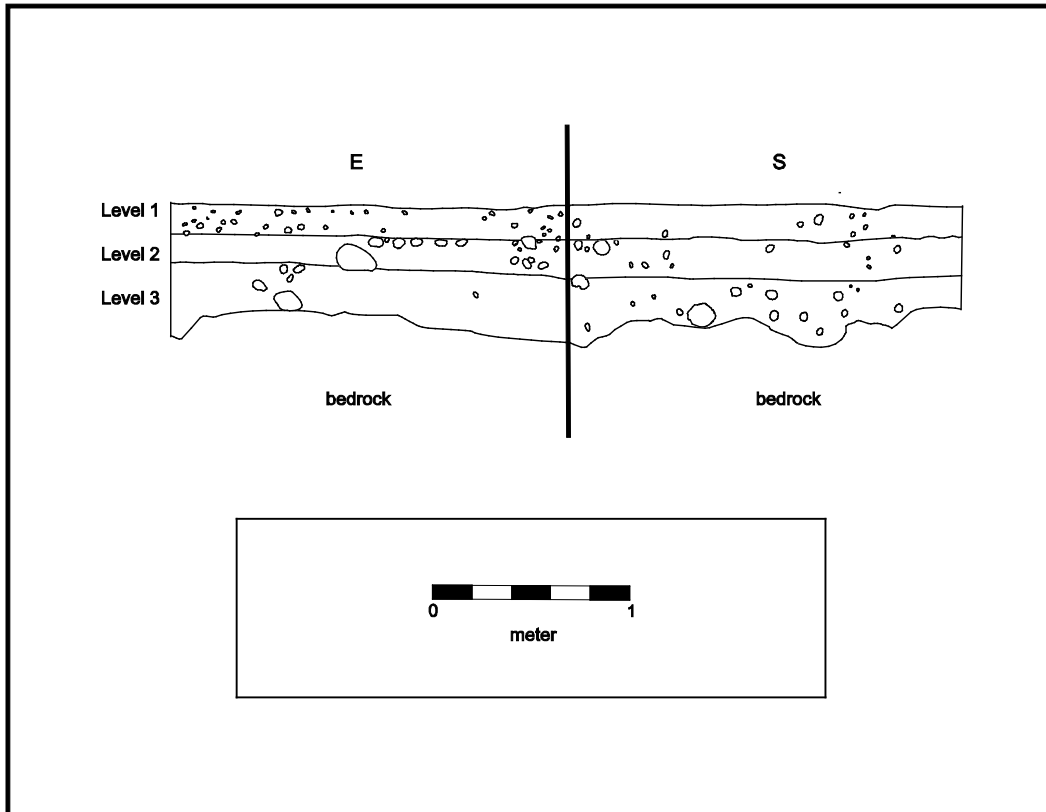

Figure 106. San Lorenzo, Operation 5, East and South Profiles

Interpretation

According to the stratigraphy observed in the excavation unit, we can suggest the following interpretation. Level 3 seems to have been part of the natural area where the first inhabitants in the site settled, composed of a red soil that conforms to the majority of the natural terrain where this Prehispanic settlement lies; there does not seem to have been a construction effort in the excavated area during that period. However, we can assume that there was a perishable construction that employed the use of posts, because one of these seems to have created the intrusion that was found at Level 3 and was designated as Level 3, Lot 2. All this must have occurred during the Terminal Classic. Thereafter, and within this same period, a new surface seems to have been created. This surface was mixed with several stones, which appear to have formed a pavement that, perhaps, was the last plaza plastered surface, corresponding to the construction of nearby buildings. Although the elements of Level 2 were not a consistent pavement, may have been a subfloor or a base for a thin plaster floor or pavement. Level 1 seems to be the material that has accumulated after the site fell into disuse. The blackish color is due to the presence of decaying organic material. Although the evidence contained within unit was not very abundant and it had shallow stratigraphy, the information obtained shows us that the activity on the site perhaps was concentrated in certain areas during certain periods, such as the area where Operation 5 lies, which only had ceramic evidence from the Terminal Classic. However, architecturally the presence of circular foundations braces (such as Structure S1E1-6) can be noted; these have been hypothesized to relate to the Postclassic. This apparent contrast of dates should be investigated in future seasons. While, no doubt, the information is very preliminary and by no means conclusive, these excavations will help us to rethink and propose our research and hypotheses in the future.

Part 4: The *Ejido* of San Felipe

Chapter 40. Sisal, Operation 2

Justine M. Shaw

Sisal's Operation 2 was conducted in order to determine whether the site's well was Prehispanic or historic in date, as well as to attempt to assign a more precise date for the well's excavation. In addition, it was hoped that the excavation could reveal whether or not its dry condition was due to intentional infilling with rocks, potentially during Caste War times. The well is located approximately 60 m northwest of the site's tallest structure, Structure S1W1-1 (Figure 107).

The original plan for the operation was to excavate the northern half of the material within the dry well, leaving the southern half of the 1.3 x 1.4 m base intact to provide a profile. However, upon entry into the 17-m-deep (from surface to current base) well, it was discovered that an eagle was using the feature as a nest for her two offspring, who were not yet able to fly. As a result, it was decided to conduct a much smaller excavation so that the excavator, birds and test pit could all be accommodated without touching the young eagles. Additionally, it was determined that, due to the stress that a day without food and the presence of a human in the immediate vicinity would provide, the excavation would only take place for one day. Other considerations included that the well's covering, which protected cattle on the *rancho* from falling into the feature, had to be removed, presenting a danger.

Initially, Operation 2 began as a 30 x 30 cm excavation, which was broadened into a 40 x 40 cm unit before the end of Level 1, Lot 1 so that material could be more easily removed. A total of seven arbitrary 10-cm levels were excavated. No significant changes were seen as depth from the surface increased, with sediment color remaining constant (7.5YR 3/4, dusky red; Figure 108) and inclusions remaining fairly consistent throughout, with the exception of a slight increase in gravel as depth increased. Relatively few sherds were present in each level. Those that were identifiable dated to the Terminal Classic.

Based upon the material that was able to be excavated in the small unit during the one-day study, only a Prehispanic occupation is evidenced in the vicinity. Material composing the fill appears to have accumulated through natural processes, with sediment, ceramics, and small rocks washing into the surface opening. Some additional rocks appear to have fallen from the sides of the well. The well opening itself opens up immediately after the surface, potentially having been used as a *sascabera* at some time. Another widening of the feature takes place approximately two meters above the modern base of the well, where *sascab* and loose cobble- to boulder-sized stones are visible. There was no evidence of intentional infilling of the feature. Although it is difficult to determine the rate at which such material would have been deposited, the presence of approximately 60 cm of excavated sediment makes it unlikely that, if the well were intentionally filled in, that this took place in recent history. If the well is not dry because of the intentional deposition of rocks or other materials, its current dry condition indicates that it was excavated at a time when the water table was

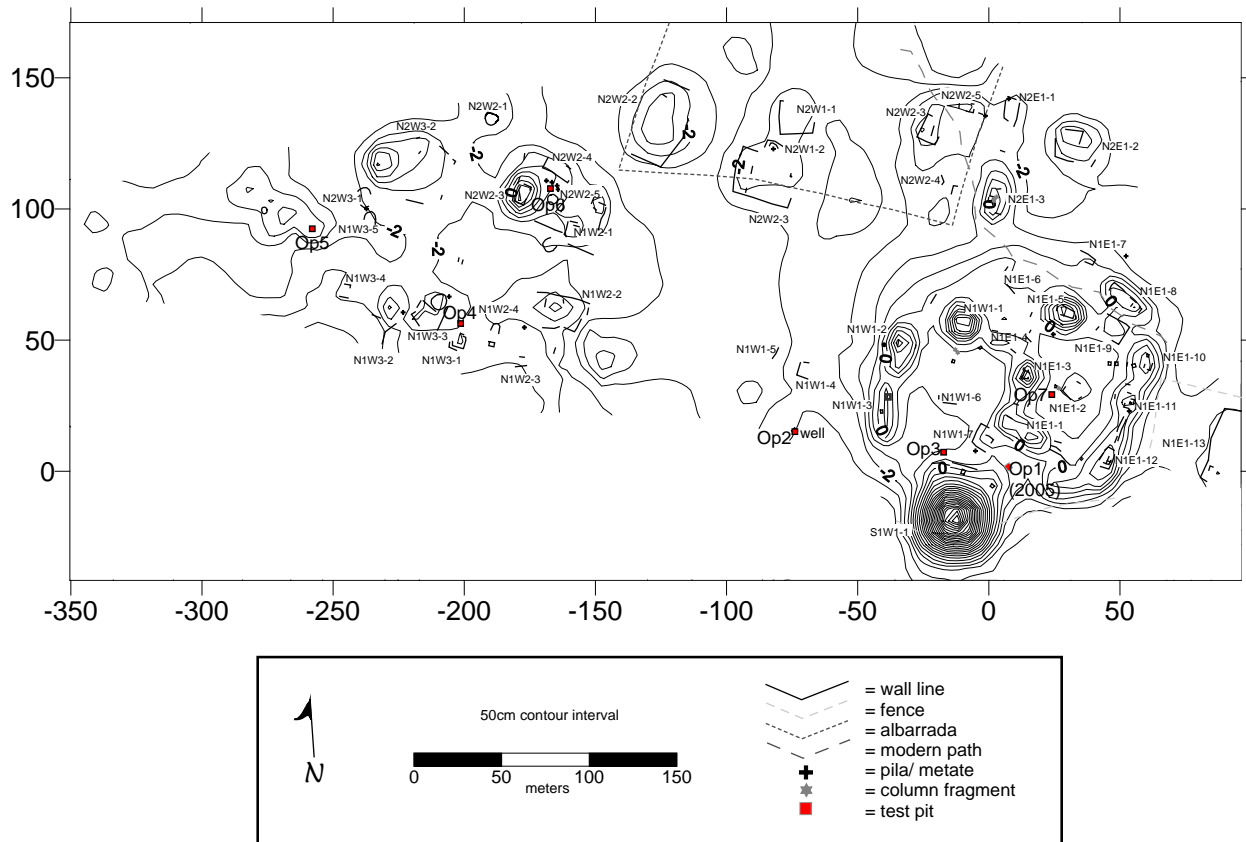

Figure 107. Location of Excavations at Sisal, San Felipe



Figure 108. Sisal, Operation 2, North Profile

higher. Alternately, it may never have been completed and the rope marks along its edges may have been created during its excavation, rather than its use. If it is unfinished, it was excavated to a depth that was quite close to the water table, as there are other wells with water in the CRAS survey area that are shallower.

-

Part 4: The *Ejido* of San Felipe

Chapter 41: Sisal, Operation 3

Alberto G. Flores Colin

According to locals, this site had been visited in the past by an INAH crew of researchers, who performed cleaning tasks and planimetric mapping. The site of Sisal was first reported by the CRAS project in 2005, when Operation 1 was conducted in a plaza area northeast of Structure S1W1-1, the highest pyramidal mound in the settlement. As part of the goals of CRAS Project survey process, we decided to perform a series of operations at the site in order to document its chronology, as well as its possible cultural affiliation (Figure 107).

Operation 3 consisted of a 2 x 2 m test pit, located in a plaza area northwest of Structure S1W1-1, near a couple of steps of the base of the platform that houses the pyramid. Adjacent to the northeast corner of the unit, a small Postclassic shrine (Structure N1W1-8) lies; it was not affected by our excavation. Excavation began with arbitrary metric levels until natural or cultural stratigraphy was located; thereafter, the excavation was carried out according to cultural levels.

The area where the excavation was located was covered with fallen leaves from the many trees that thrive in the region of this Prehispanic site. The area is a small island of "high forest" or primary vegetation between terrains devoted to livestock and seasonal agriculture. Level 1, Lot 1 corresponded to a layer composed of a mixture of black soil, rich in decaying organic material, and various sized stones, from boulders of about 40x40 cm to 2 x 3-cm gravel. Furthermore, it had remains of stucco (in pieces or in small fragments) and *sascab* (limestone powder) that had apparently come from the nearby pyramidal structure (Structure S1W1-1). Ceramics found in the level were not very abundant, although some Chen Mul Modeled censers fragments make us suppose that this level corresponds to the Postclassic. Below this layer, Level 2, Lot 1 was found, which was formed by a layer of dark brown soil (10YR 4/2), mixed with much *sascab*, highly compacted in certain areas, that seemed to be a highly degraded surface. The level ended with the discovery of Floor 1 or Level 3 that was formed by a poorly preserved plastered floor, probably because this was the last surface to be exposed to erosion when the site was abandoned. This was confirmed by the presence of well cut stones that had collapsed from the façade of the Structure S1W1-1 and were lying just above the floor. Due to its preservation condition, it was decided to divide this level into two lots. Level 3, Lot 1 for the portion where floor was missing and Level 3, Lot 2 for the sealed portion of the floor, in other words, the area that still had its polished surface (Figure 109). Lot 1 (the unsealed section) was removed first, to later continue with the excavation of the sealed portion. The floor had a whitish brown color (10YR 8/3, very pale brown), composed of a mixture of small pebbles, *sascab*, and a few ceramic sherds. Removal of all this level led to the discovery of what appeared to be a sub-floor (*tzeék* in Yucatec Maya), so it was decided to conclude this level to start a new level. Level 3, Lot 2, like Lot 1, consisted of the same stucco floor, mostly of a

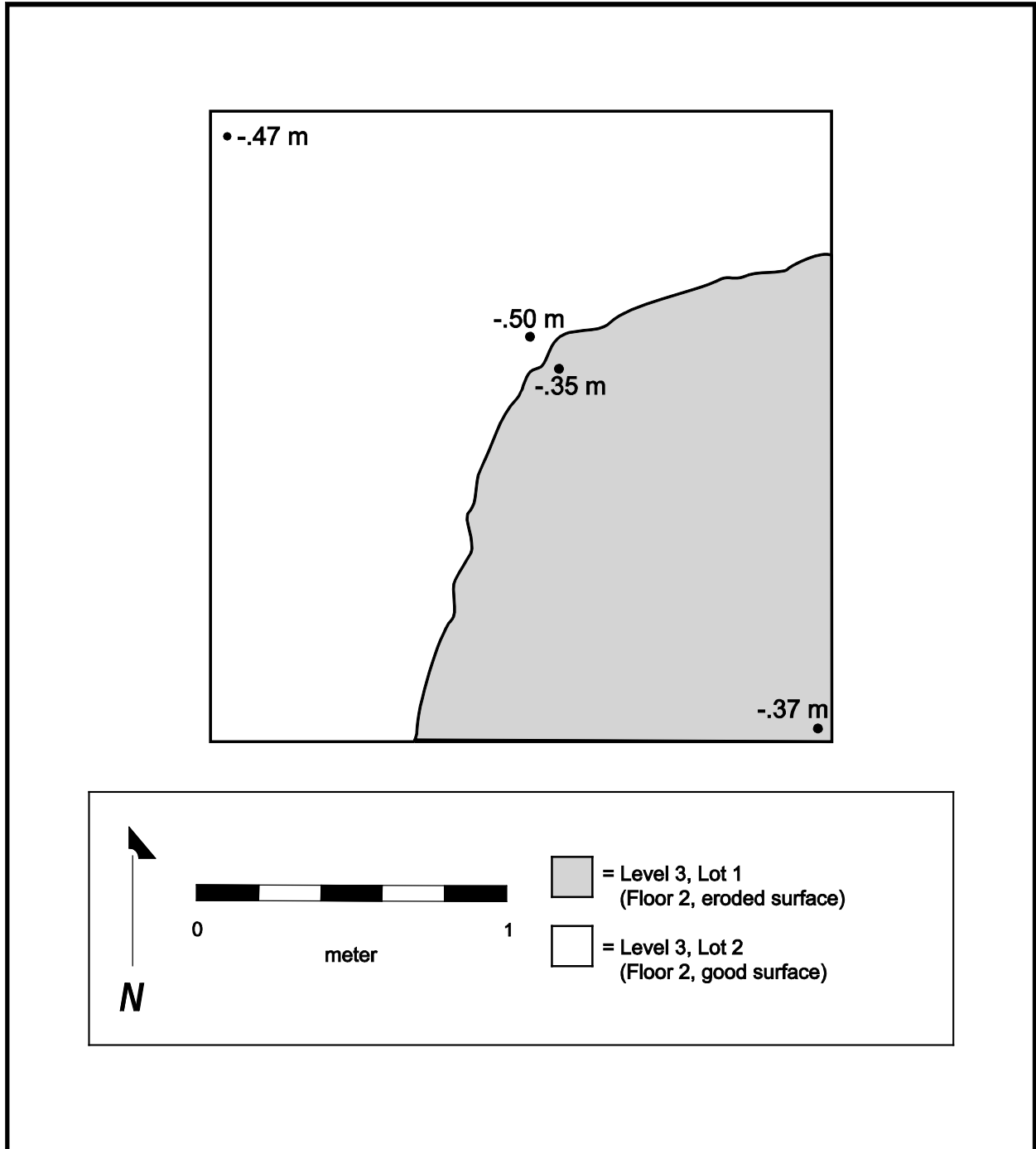

Figure 109. Sisal, Operation 3, Level 3, Lots 1 and 2

mixture of *sascab* (limestone powder) and a few pebbles. Removal of the lot also ended with Level 4. Ceramics located in both lots corresponded to the Terminal Classic period, evidenced by Muna Slate sherds (see Chapter 48 for ceramic detail). Level 4, Lot 1, unlike the previous level, was formed by abundant and highly compacted gravel or *chich*, mixed with a small amount of *sascab* that functioned as a mortar. Usually, this composition is prepared as the base for a plastered floor, even for modern, polished concrete floors. The color of the level was the same as above (10YR 8/3, very pale brown), as was its date (Terminal Classic), since both levels are part of the same construction effort. However, during the excavation process, we separated them because of their composition, which differs in the number and size of stones used in their preparation, in order to get a better understanding of the construction techniques. Removal of this layer resulted in the discovery of a second stucco floor (Floor 2), which was designated as Level 5, Lot 1. This stucco floor, whose surface was very eroded, had the same whitish-brown color as the above floor (10YR 8/3), and consisted of a well sorted *sascab* with a few pebbles (about 7 x 7 cm on average). No ceramic sherds were located in the deposit. Removal of this layer concluded with the discovery of another floor (Floor 3). The surface of Floor 2 was quite degraded, as it seemed to be a compacted surface instead of a formal, polished floor. However, it is quite possible that the final surface of the floor has been eroded during an abandonment period. Level 6, Lot 1 corresponded to Floor 3, mainly presented an eroded surface, although three small areas still had a polished and intact surface. For that reason, this level was also divided into two lots (Level 6, Lot 1 for eroded surface, and Lot 2 for the well preserved), in order to have better control over materials that could be obtained. With the excavation of Lot 1, we discovered that this floor was about 20 cm thick and consisted of a mixture of fine *sascab* (white 10YR 8/2) and a few small stones. Within the layer were a series of flat stones that probably served as the base for the floor, although the rocks were distributed across the entire unit and did not present a homogeneous distribution. Level 6, Lot 2 corresponded to three small areas where the floor surface was intact. The composition and coloration of this level was the same as Level 6, Lot 1 (*sascab* with some small stones, white 10YR 8/2), since they are part of the same construction effort. Removal of the entire level (Level 6, Lots 1 and 2) led to the discovery of a fourth floor that had all its polished surface complete, with the exception of the south section, where a few broken patches were found. Floor 4 (Level 7, Lot 1) was a stucco floor that was relatively thin (about 7 cm), composed of small pebbles and *sascab* (10YR 8/4, very pale brown). The base for the floor was composed of several blackish stones, of 5 x 7 cm on average. In the southern part of the unit, and immediately below the floor, there seemed to be a step or a low wall of a substructure (Feature 1). Thus, it was decided to divide the unit in two lots, Level 7, Lots 1 and 2, with the aim to recording the excavation in better detail. Feature 1, either wall or step, was cleaned and recorded. It was left *in situ* for further consolidation after the excavation process was concluded. No ceramic sherds were found in this level. The end of the deposit was marked by the location of several medium size stones (about 20 x 20 cm on average) that were designated as Level 8, Lot 1 (Figure 110). Once excavated, it was found that dry core fill, without mortar, covered the entire unit. The potential step (Feature 1), located to the south of the operation, may also be part of a construction box, since this alignment was at the same level as the construction fill.

However, since only a small section fell within the unit, any interpretation of Feature 1 would be inconclusive. Nevertheless, because its characteristics (well cut stones) and its position, we think that this was part of a step or a low wall of a modified sub-structure. As mentioned, this alignment was left *"in situ"* to be consolidated at the end of the excavation. Ceramically, the level belongs to the Early Classic, as evidenced by Xanaba Red and Yaxcaba Striated ceramic sherds. Beneath this fill, Level 9, Lot 1 was located; it was a layer of strong brown soil (7.5YR 5/6), mixed with rough stones. Sediment within the deposit was much grittier than the previous one, possibly due to degradation of the stucco that formed Floor 4, and would have lain over the dry fill. Ceramics located at this level were scarce, but belonged to the Early Classic period. Below this level was Floor 5 (Level 10, Lot 1), which presented a very degraded surface, giving the appearance of a compacted area instead a floor. Probably this floor (very pale brown, 10YR 8/3 in color) had a polished surface. However, it is highly eroded due, perhaps, to the filtered liquids that pass through the dry core fill. The floor was composed of both *sascab* and some blackish pebbles or *chich*. The thickness of the floor was roughly 5-7 cm, and apparently is the result of a re-paving or a repair by maintenance of Floor 6 (Level 11, Lot 1), which was discovered under Floor 5. As with the above level, Level 11 also had a quite eroded surface and was composed of limestone powder and blackish gravel; it had a pale brown color (10YR 8/3). At the end of the level, another floor (Floor 7, Level 12, Lot 1) was revealed. As with the previous two, it also gave the appearance of compacted material without a polished surface, but probably was very eroded, either because it was exposed to the environment or through liquid that passed through the dry fill (Level 8). Unlike the two previous floors (Floor 5 and 6), this seventh floor was mostly composed of a fine *sascab* (1 YR 8/3, very pale brown). These three floors belong to the Early Classic period. Removal of the previous level ended in the discovery of a *chac luum* (in Yucatec) or red soil layer, mixed with a very fine *sascab*, possibly part of an eroded plastered surface. This red soil was very claylike in consistency (2.5YR 4/6), and was mixed with medium-sized (20 x 20 cm) stones. This red soil or *chac luum* (Level 13, Lot 1) generally corresponds to the natural surface of this part of Yucatan; thus we assume that this layer is close to the original terrain of the first settlers. Ceramics found at this level also belonged to the Early Classic. Level 14, Lot 1, consisted of a floor that only was located in some small areas of about 20 x 30 cm, which still had smooth surfaces. Floor 8 was not located at the same level throughout the unit, but lay at different depths and consisted of fine *sascab*, placed without any previous preparation, that is, without any base or sub-floor, positioned directly upon the *chac luum* or red soil, which presumably corresponds to the natural surface of the terrain at the time. For this reason, we hypothesize that this floor was the first floor of the earlier settlers who built their first constructions directly on the natural surface. Also notable is that this floor was also covered with *chac luum*, which indicates that perhaps the people who decided to cover it used the closest material, furthermore with less preparation to give a new elevation to this surface (Level 12, Lot 1, corresponding to Floor 7). In the northern part of the unit was a section of bedrock, at the same level than the floor. This Floor 8 was constructed, at least partially, directly over the limestone outcrops visible at that time, thus confirming the idea of this was the natural surface observed by the first settlers.

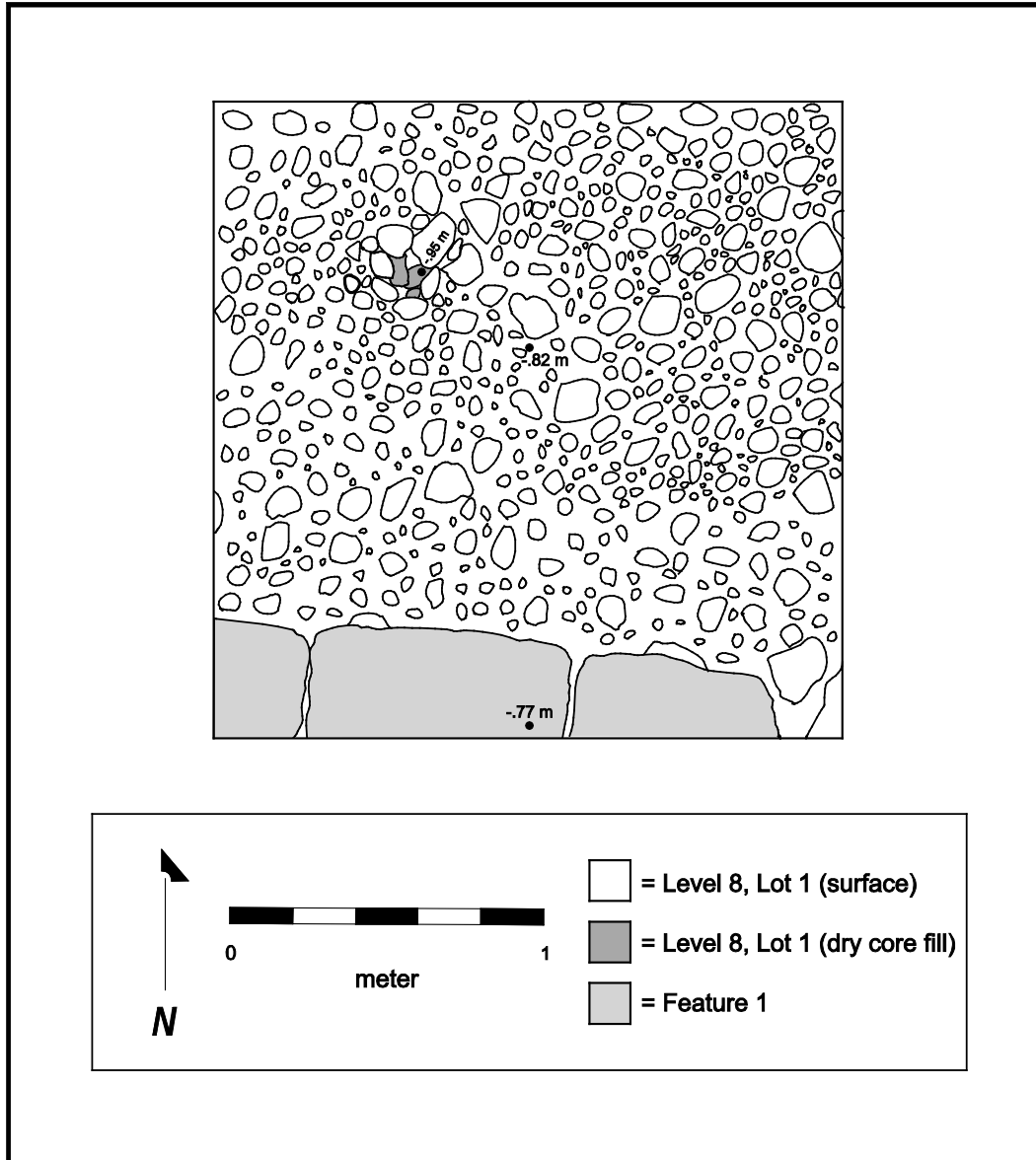

Figure 110. Sisal, Operation 3, Level 8, Lot 1 and Feature 1

Below this floor were the remains of the last level, Level 15, Lot 1. This level consisted of a bed of pebbles mixed with red soil, which corresponds to the degraded bedrock created by filtrations from the surface, evidenced by the whimsical shapes of the small pebbles. Once this part of the bedrock was removed, the solid bedrock or *chaltún* (in Yucatec) was located. In other words, this was the terminus of the excavation process of this unit (Figure 111). The color of the layer was red (2.5YR 5/6). The ceramic sample was small, but belonged to the Early Classic period, although a couple of Terminal Classic Yokat Striated and Muna Slate sherds were also located. We speculate that these later samples may have fallen and accidentally mixed from a higher stratum, during the ascent and descent of the excavators (the depth of this stratum was over 1.90 m).

Based on the stratigraphy and ceramic dating of this unit, we propose the following sequence. The occupation in this area of the settlement began during Early Classic, when the natural landscape with several limestone outcrops was covered with a thin layer of polished plaster, creating the first plaza surface in this portion of the settlement. At some point during this period, it was decided to cover this floor (Floor 8) and raise the plaza level by about 30 cm, creating a new plastered surface (Floor 7). This new plaza area was constructed with red soil or *chac luum*, which is the natural soil of this part of the peninsula; thus, we suppose that the material employed in this level comes from a nearby area, and was collected from the surface. Floor 7 (Level 12) was followed by a series of re-pavings of the plaza surface (Floors 6 and 5, Levels 11 and 10 respectively), perhaps as part of periodic maintenance that was conducted in the main portions of Sisal. All these events occurred during the Early Classic. Later, another re-leveling of the plaza was carried out (as reflected in Levels 9, 8 and 7). This construction effort began with dry core fill, without mortar, as the base of what would be the Floor 4. Floor 3 and Floor 2 (Levels 6 and 5) were re-paving layers that were placed above the Floor 4, perhaps as part of maintenance tasks that the plaza received at certain periods. Although no ceramic sherds were located in all these levels, some fragments located on Floor 4 lead us to believe that this series of re-paving evidences also belong to the Early Classic. Following this, the plaza area was covered with another floor (Floor 1, corresponding to Level 3), that was raised above a sub-floor (Level 4) of about 20 cm from the previous stratum (Floor 2). Ceramically, Floor 1 was related to the Terminal Classic, thus we assume that the later re-leveling and plastered surface of this plaza would have occurred at some point during that period. Following this, during Level 2, an accumulation of collapsed materials took place, mainly from Structure S1W1-1. Within this debris, we found several façade elements, so we believe that the building was abandoned or at least had not received any maintenance for a long time. During this period was when the small Postclassic shrine (Structure N1W1-8), located at the northeast corner of the unit, was built or in use. Ceramic fragments of Chen Mul Modeled *incensarios* provide evidence of the use of the shrine. The most recent level (Level 1), is also part of the collapse event and the deposition of materials from Structure S1W1-1, since these are mixed with the decaying organic material from the tropical forest that covers the settlement.

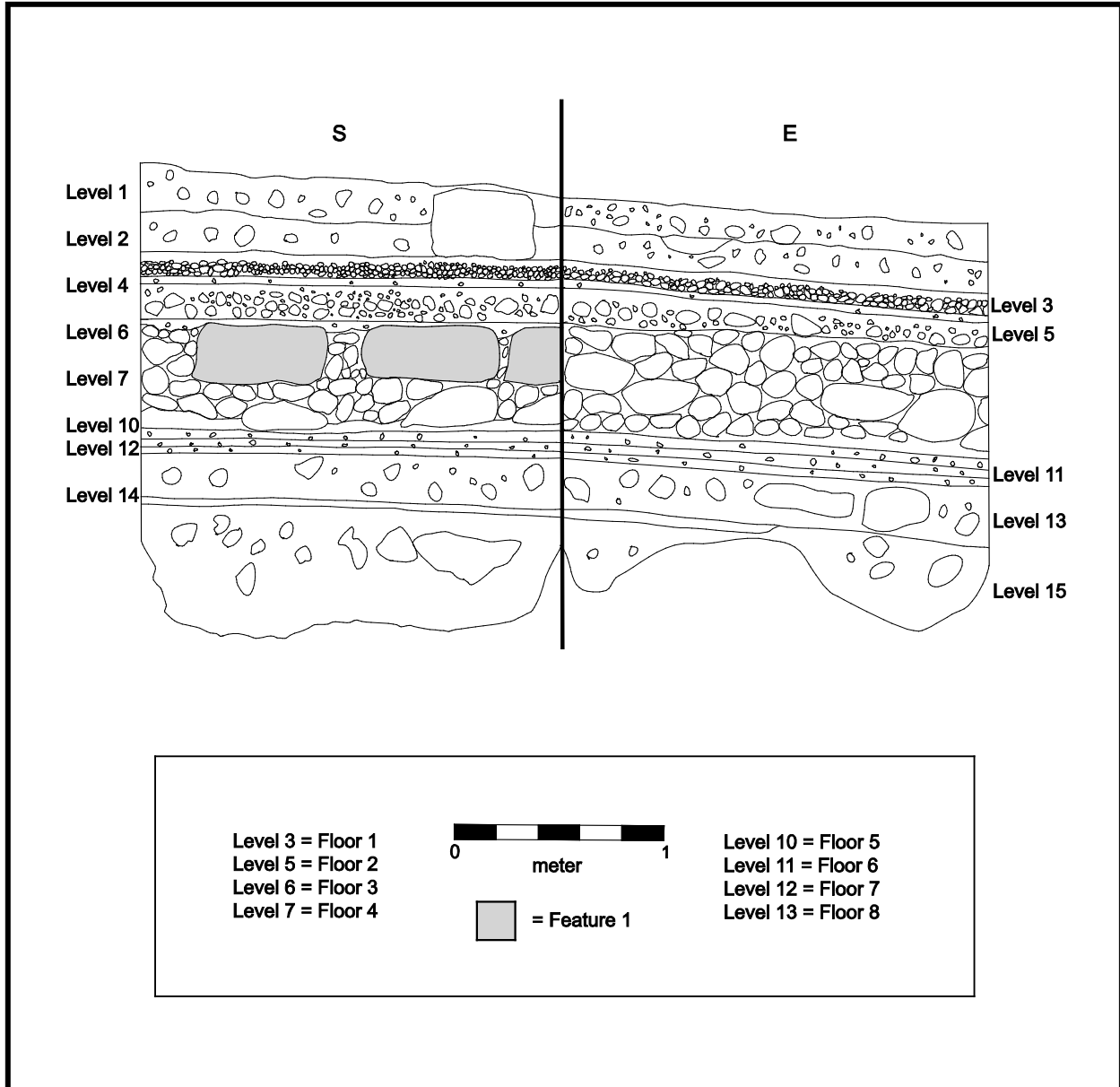

Figure 111. Sisal, Operation 3, South and East Profiles

According to the above mentioned information, we can postulate that this part of the site was occupied during Early and Terminal Classic periods, which should correspond to a construction peak in this portion of the settlement. Although the Postclassic evidence is undeniable, it seems that the inhabitants of this period no longer constructed monumental buildings, at least not in this plaza area. During the Postclassic, this portion of the settlement was only occupied by perishable constructions or small shrines (there are four in this plaza alone), perhaps related to rituals of ancestor worship, which evidence the importance that the place maintained in this later period. This was quite different from the use that this spot had during Early and Terminal Classic periods, when building projects took place. Evidence from other operations at the site, as well as future excavations, will help us to obtain a better understanding about the occupations and processes that occurred at the site of Sisal.

Consolidation

Feature 1, a low platform wall or step that was located in the southern part of the unit had been left *in situ* for a further consolidation. That process began with the cleaning of the stones that conforms said feature. Following the above mentioned cleaning, the replacement of the degraded mortar with new (composed of three parts of lime, three parts *sascab* [limestone powder] and one part white cement) took place. This substitution was carried out in order to ensure their preservation and stability. Once this necessary process was concluded, and after the proper documentation through drawings and photographs (Figure 112), the unit was backfilled to its original level. During the backfilling of unit, Feature 1 was covered with fine soil layer as well as a line of medium-sized stones along its perimeter in order to ensure its protection and stability in the future.



Figure 112. Sisal, Operation 3, Feature 1 Consolidated

Part 4: The *Ejido* of San Felipe

Chapter 42: Sisal, Operation 4

Justine M. Shaw, Thania E. Ibarra Narváez and Alberto G. Flores Colin

Sisal's Operation 4 was located east of the wall of Structure N1W1-3, which had a probable residential use. It was a 2x2 test pit, conducted in order to obtain part of the chronology of this settlement. The surface was covered with small shrubs and medium-sized trees. Four levels were excavated before reaching the bedrock. The first two of those were arbitrary (10 cm each) and the last two were cultural.

Level 1 was a 10-cm arbitrary level, removed in a single lot. It was formed mainly by a very dark brown soil mixed with gravel and numerous ceramic sherds. Also a few lithic fragments were located. Ceramic samples included Terminal Classic Yokat Striated and Muna Slate types.

Since no cultural division was observed, the following level was also removed as a 10-cm arbitrary layer; Level 2 was removed as one lot. Sediment from this level was very sandy, but also contained a dark brown soil mixed with stones and ceramic fragments, although in lesser quantities than in the previous level. Collected sherds are of the Yokat Striated ceramic type (Terminal Classic).

The next level was a layer composed of boulders. It was designated as Level 3 (Figure 113). This was a definite cultural level since it seemed to be construction fill, deposited with the intention of leveling the terrain; if there was a floor or pavement it had disappeared due to exposure and erosion. A fine dark reddish brown sediment was mixed with the boulders. Ceramics samples found in this layer are from Terminal Classic (Yokat Striated), but also a few Late Formative Sierra Red sherds were located. A very few Early Classic and Late Classic fragments were identified. With regards to lithic material, a few fragments were found but in lesser proportions than in previous levels. According to the ceramic data, we believe that this construction fill was built up during Terminal Classic, by means of the re-use of Late Formative rubble that had been discarded through time.

At 30 cm deep, the stones became larger than before, as they formed the base for the construction fill. Sediment from the level was quite fine, with a dark reddish brown color. Collected samples were much smaller than prior levels; they were mostly Yokat Striated (Terminal Classic) with a few Middle Formative, Late Formative and Early Classic sherds. Therefore, we assume that the base of the fill also was completed during the Terminal Classic. A single piece of flint was located, a minor sample compared to the prior levels.

Once all boulders were removed, bedrock was discovered at 1.06 m deep (Figure 114). Sediment above the bedrock was a reddish soil, locally called as *chac luum*, perhaps the earliest occupational area in this portion of the site.

Sisal Operation 4 shows how this area was leveled for use as a residential area, which must have occur during Terminal Classic, by placing stone fill, rubble, and ceramic debris from earlier and contemporary periods. Therefore, the occupation of this area and the adjacent structure occurred during Terminal Classic. No Postclassic samples were located. Thus, we assume that there was no Postclassic occupation in this portion of the site or, if it existed, was quite ephemeral.



Figure 113. Sisal, Operation 4, Level 3, Lot 1

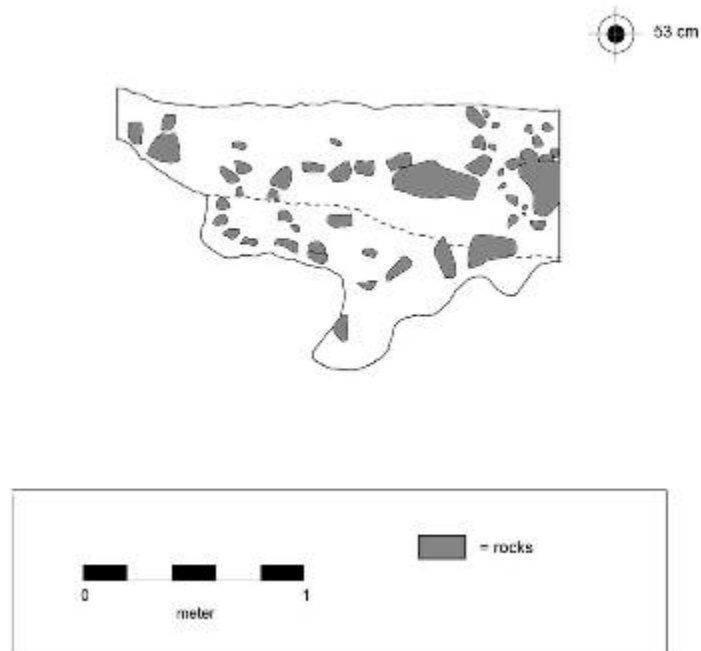

Figure 114. Sisal, Operation 4, North Profile

Part 4: The *Ejido* of San Felipe

Chapter 43: Sisal, Operation 5

Justine M. Shaw and Luis Fernando Hernández Lara

Operation 5 is located in western portion of the site, roughly 250 m from the main architectural group. Today, this area is used by the inhabitants of the *ejido* of San Felipe as pasture land for their cattle and seasonal agriculture. This test unit was a 2 x 2 m test pit, excavated through 10-cm arbitrary metric levels since no cultural stratum was found. Operation 5 is located within a *rejollada* or low area, a landscape feature common in this area of the Peninsula. The aim of this operation was to investigate if this depression had been used for collect water or for some other hydraulic purpose; thus a cultural feature, such as a wall or surface, was expected.

The surface of the unit was covered with dead leaves and other herbs (mostly grass), as well as carbon chunks and burned soil, the products of the slash and burn agriculture technique. Level 1, Lot 1 consisted of red and burned soil mixed with carbon pieces and a few pieces of gravel. Ceramics were quite scarce and are from various periods (Late Formative, Middle Classic, and Terminal Classic). There was a higher concentration of large rocks (20 to 40 cm) on the western side of the test unit. Following the removal of Level 2, Lot 1, a sort of large rocks alignment at the center of the unit was discovered that would be present until the excavation reached bedrock. Likewise, ceramics samples were scarce, having the same dates as the previous level.

In Level 3, Lot 1, a very thin layer of what seemed to be ash was found, mostly under some of the large rocks in the western portion of the pit. This thin layer could correspond to the degradation of the limestone. Ceramic material recovered is from Late Classic, but was also limited. Following this was Level 4, Lot 1, but ceramics findings were equally scarce, also belonging to the Late Classic. Because of the large rock alignment of stones the continued in the central part of the pit, the unit was divided into two separate lots, Lot 1 to the east, and Lot 2 to the west, since it was believed that the alignment could be a sort of cultural feature. In both lots of Level 5, ceramics from Early and Late Classic were collected, and the same ash-like patches were found underneath some rocks. Level 6 presented a slight difference in color between the two lots; furthermore a new rock clustering was located in the western area (Lot 2). Ceramics samples, also scarce, belonged to the Early Classic (Yaxcaba Striated) and Late Classic (Dos Caras Striated, Saxche Orange Polychrome) periods (Figure 115).

Both lots of Level 7 had more sherds than all the previous levels. The color of both was also nearly equal (5YR 6/3). Lot 2 contained more samples than Lot 1. All sherds were from Terminal Classic (Yokat Striated and Muna Slate types). Beneath the stones, bedrock was discovered, marking the end of the excavation. This last level (Level 8) had a grayish brown color (5YR 6/3). The rock alignment at the center of the pit was seated directly over bedrock, but there was no material that seems to be joined, between the north and south profiles. Ceramics sherds located were quite more

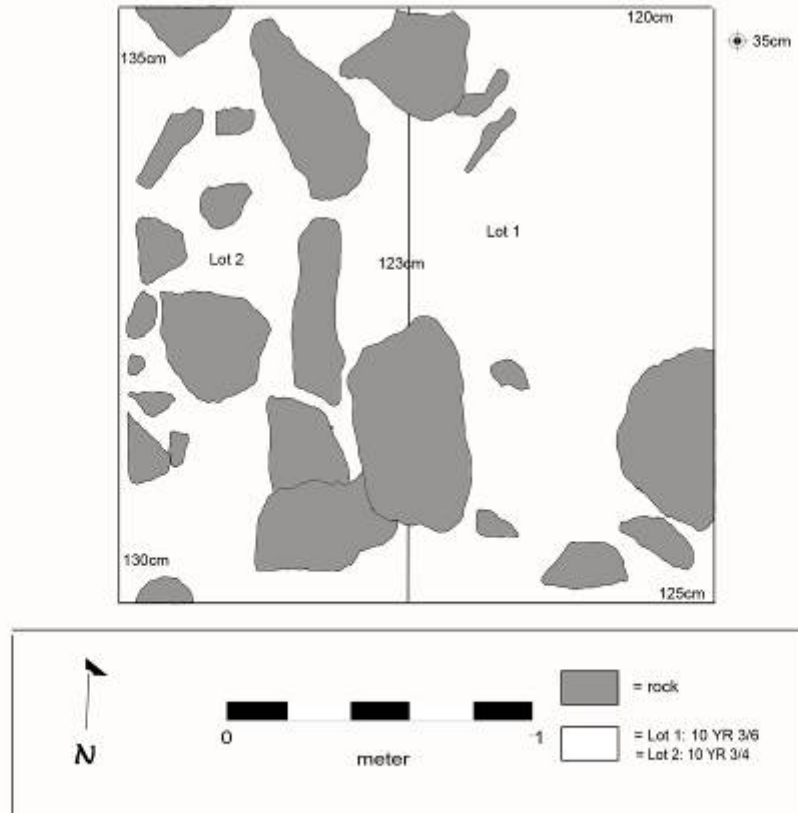

Figure 115. Sisal, Operation 5, Level 6

abundant than in previous levels, dating from the Early Classic (Dos Arroyos Orange Polychrome), while others were from the Terminal Classic (Yokat Striated and Muna Slate) (Figure 116).

Interpretation

No cultural levels were found in this unit. Ceramic samples seemed to be quite mixed, but most activity can be dated to the Terminal Classic. At first glance, the rock alignment at the center of the unit seems to be a sort of feature, possibly to contain or retain water. However, there is no evidence to suggest that this series of rocks have a cultural origin. This first unit excavated at one of the site's *rejolladas* makes us reconsider the possibility that these natural depressions may have been used to collect and contain water. It seems more feasible that its deeper soils were more suitable, as it is today, for sowing more valuable crops such as cocoa, bananas or cotton, for which these depressions are most appropriate. The problem of water collection and storage will have to be investigated further in future seasons.

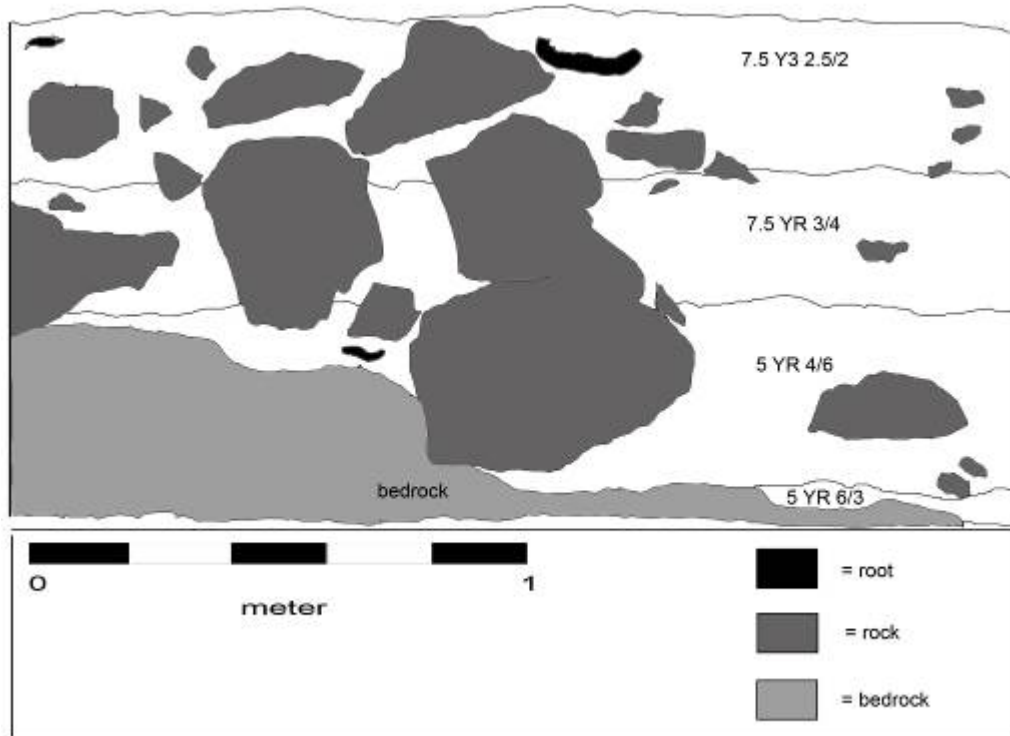

Figure 116. Sisal, Operation 5, North Profile

Part 4: The *Ejido* of San Felipe

Chapter 44: Sisal, Operation 6

Justine M. Shaw and Vania Carrillo Bosch

As part of the 2010 CRAS Project's goals, a series of operations were conducted in order to document the chronology and cultural affiliation of the site of Sisal. Operation 6 was a 2 x 2 m test pit, positioned on what seems to have been an activity area. Southwest and northeast of the pit were two structures (Structures N2E1-2 and N2E1-3) and, in between, were a series of six "*pilas*" or *metates* (millstones). Excavation began with arbitrary metric levels, which let us have a better control until natural and cultural levels were located.

The surface of the pit was composed of a very dark brown and soft sediment (7.5YR 3/2) mixed with carbon fragments, since in previous years this area had been burned for agriculture purposes. Below this surface was Level 1. Level 1, Lot 1 (Figure 117) was formed by a very dark brown soil (7.5YR 3/2), roots, carbon remnants, and medium-size stones. This level was quite compacted. A large quantity of ceramic sherds was located, mainly from the Postclassic (Chen Mul Modeled), as well as from the Terminal Classic (Muna Slate and Yokat Striated). Level 2, Lot 1 (Figure 118), was composed of a dark brown sediment (7.5 YR 3/2) that was not very compacted and mixed with medium-sized stones (20 to 50 cm), which were placed without a clear pattern. Thus, we assume that they are part of the collapse of the nearby structures. Ceramic material recovered mainly corresponds to types from Terminal Classic (Ticul Thin Slate, Muna Slate and Yokat Striated). Level 3, Lot 1, containing a dark brown sediment (7.5 YR 3/2), consisted of a numerous medium-sized stones (6 to 15 cm) that were placed uniformly to form a surface. Ceramic material recovered mainly corresponded to Terminal Classic types (Muna Slate and Yokat Striated). Level 4, Lot 1 consisted of grayish-brown soil (10YR 5/2), mixed with small pieces of *sascab* (about 1 mm) and many stones that increased their size with depth, from medium to large (20 to 80 cm). Ceramic material recovered belongs to the Terminal Classic (Muna Slate and Yokat Striated types). Below this level, the last level was found, which consisted of bedrock or *chaltún* as stated in Maya Yucatec (Figure 119). Excavation of this unit concluded at a depth of 159 cm with bedrock.

Interpretation

Based on stratification and ceramic analyses, we can postulate the following chronological sequence. The activity in the area must have started during the Late Formative period; the surface may have been Level 4. We propose that the stones found within Level 3, Lot 1 comprise a surface that had been constructed during the Terminal Classic. With regards to Level 2, we speculate that a series of large stones that were located are part of the collapse process since they no show any pattern in their distribution. The majority of the sherds in this deposit date to the Terminal Classic, although there are some example fragments of Postclassic Chen Mul Modeled sherds. Therefore we think that the site may already have been abandoned

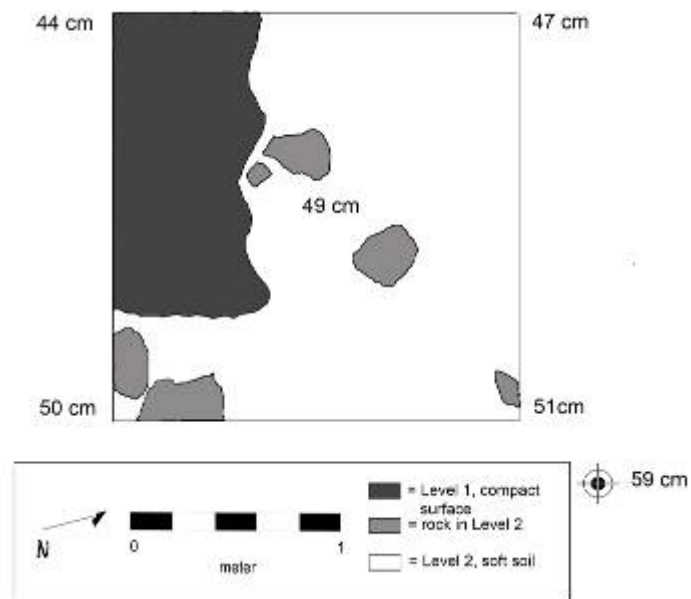

Figure 117. Sisal, Operation 6, Level 1 and 2

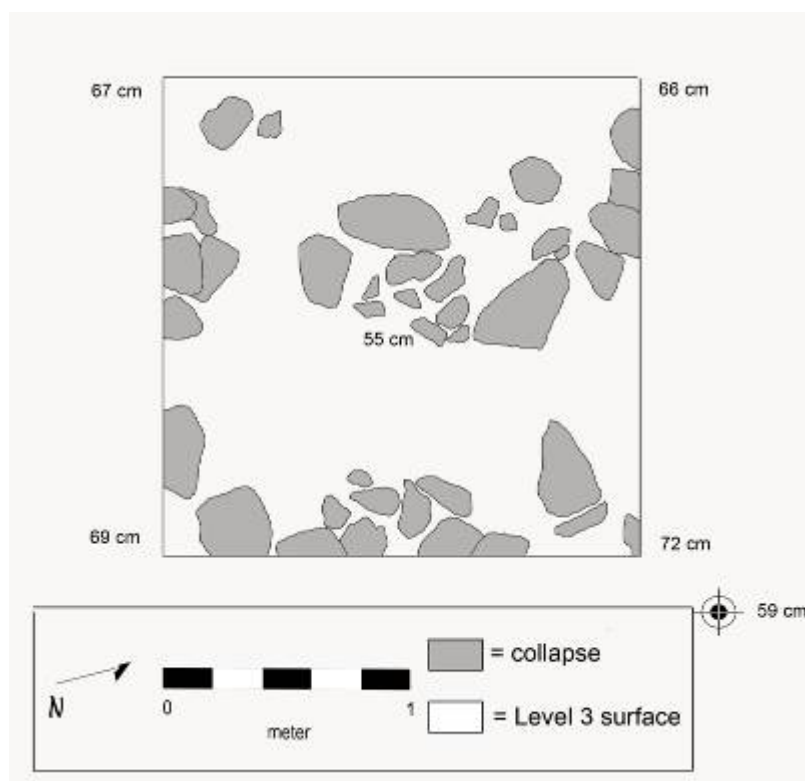

Figure 118. Sisal, Operation 6, Level 2 and 3

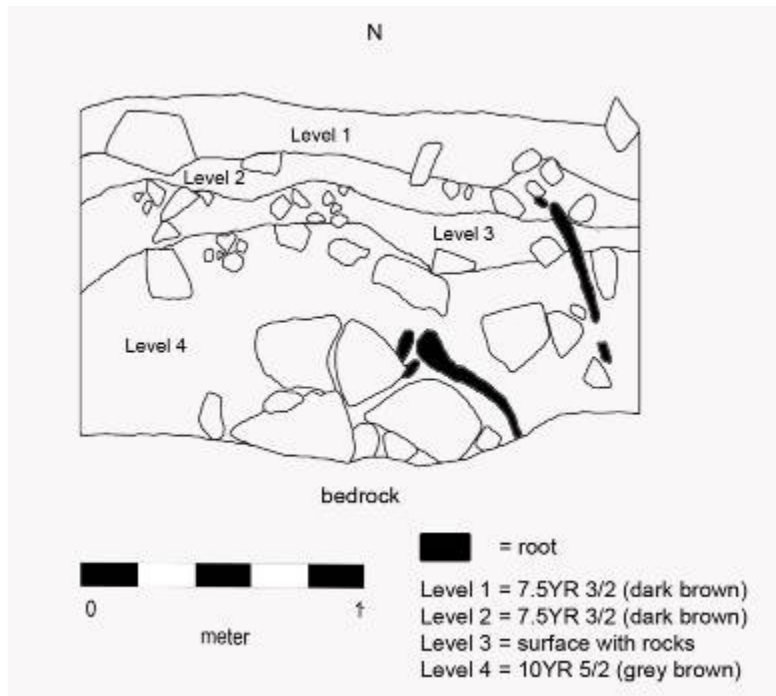

Figure 119. Sisal, Operation 6, North Profile

by the end of the Terminal Classic, since evidence of Postclassic activity was ephemeral, perhaps limited to a few occasional visits as part of an ancestor's worship. Evidence from other units excavated at the site will help us to understand the occupations and temporality of the settlement.

Part 4: The *Ejido* of San Felipe

Chapter 45: Sisal, Operation 7

Bryce Davenport

Sisal's Operation 7 was undertaken to better understand the construction and occupational history of Structure N1E1-3. The 2 x 2 m test pit was placed in the plaza due east of Structure N1E1-3, approximately 3 m from the edge of the structure's collapse. Although Structure N1E1-3 was likely peripheral to and possibly intrusive into the main plaza plan (Shaw and Flores 2008: 185), its construction did not appear to be significantly later than other acropolis structures. It was hoped that this test pit would include sealed plaza floors that might contain materials pertaining to the construction and use of Structure N1E1-3 (Figure 107).

The first excavation lot (Operation 7, Level 1, Lot 1) contained dark brown, organic sediment (7.5YR 3/2) with a high concentration of roots. The overwhelming majority of identifiable sherds were from the Terminal Classic, with only a single sherd linked to the Postclassic. An arbitrary level was declared at 10 cm below the surface for control purposes. The second lot (Operation 7, Level 2, Lot 1) was also excavated to an arbitrary level of 20 cm, and contained the same soil as the first lot. No sherds were recovered from the second level (Operation 7 Level 2 Lot 1). The third arbitrary level (Operation 7, Level 3, Lot 1) ended at 30 cm, and contained exclusively Terminal Classic sherds. The soil consistency became a much looser, brown sediment with fewer organic particles (7.5YR 4/2).

The unit's first cultural level was located at 32 cm, with soil changes and a large concentration of pebbles in the northeastern quadrant. This level was divided into two lots, with the primary (Operation 7, Level 4, Lot 1) occupying the areas shown in Figure 120. The soil was a grayish brown (10YR 5/2) and contained many pebbles, presumably either pieces of a degraded plaster surface or fill. The soil maintained this consistency until the next level. Very few sherds were recovered from this lot, all of which were Terminal Classic. The second lot (Operation 7, Level 4, Lot 2; Figure 122), originally separated because of its firmer consistency, lighter color (7.5YR 6/2), and higher concentration of pebbles, was consolidated into the next level (Operation 7, Level 5, Lot 2), which shared these qualities and formed a rough surface.

This level (Operation 7, Level 5, Lot 1 and Lot 2) contained the first recognizable plaza floor of the unit at a depth of 39 cm. The surface was very uneven, and was divided into two lots based on composition and coloration (Figure 121). The primary lot (Operation 7, Level 5, Lot 1), from the southeastern quadrant, lacked intact stucco material and contained light gray (10YR 7/1) soil with numerous pebbles. The small numbers of recovered sherds were Early Classic and Late Formative. The sealed floor surface (Operation 7, Level 5, Lot 2) was lighter in color (10YR 8/1), and consisted of a thick, rough plaster layer. The floor was 2-3 cm thick, with *chich* fill mixed into the lower portion. Sherds recovered from this lot are Early and Terminal Classic, with the more recent period being represented more strongly.

The second plaza floor (Operation 7, Level 6, Lots 1 and 2) was reached at 49 cm, and was better preserved than the previous example. Almost the entire surface was

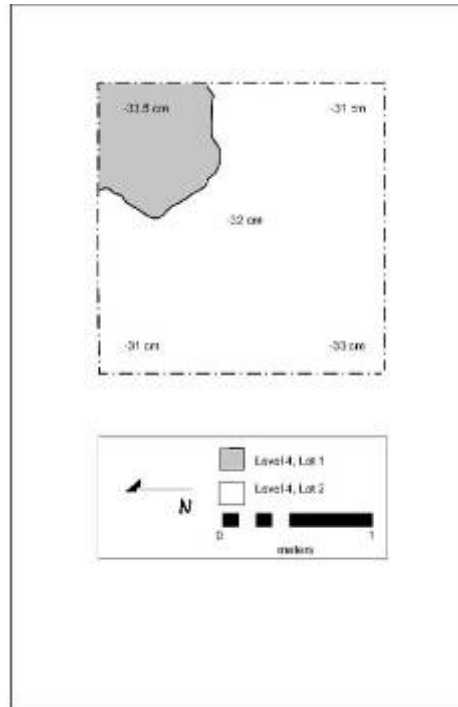

Figure 120. Sisal, Operation 7, Level 4

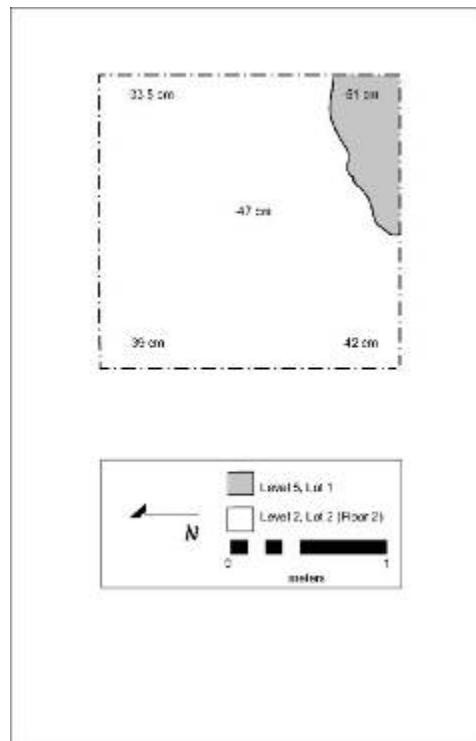

Figure 121. Sisal, Operation 7, Level 5

intact, although two lots were established based on a consistency and soil color change for a portion of the northeastern quadrant (Figure 122). This irregularity formed the primary lot (Operation 7, Level 6, Lot 1), which was excavated to a depth of 81.5 cm before encountering another plaza surface, although additional floor levels were visible in the lot's (Operation 7, Level 6, Lot 1) profile. The soil in this lot was pinkish gray (7.5YR 7/2), with a light brown deposit underneath. No sherds were recovered from Operation 7, Level 6, Lot 1, and it is hypothesized that this lot formed a post-hole or plant growth through the plaza floor.

The secondary lot (Operation 7, Level 6, Lot 2) contained a very smooth plaza surface, with light gray soil (10YR 7/1). The floor was 6-8 cm thick, and the profile later revealed that this level actually contains two floors, one directly plastered over the other without intervening fill (Figure 123). The fill beneath the second floor was comprised of *chich*, plaster fragments, and small pebbles, with a high incidence of reddish limestone. A single identifiable sherd was recovered from this lot, dating to the Early Classic. The smooth service of Operation 7, Level 6, Lot 2 showed a clear depth gradation from north to south, a trend repeated in subsequent levels. Whether this is the result of taphonomic processes or an intentional feature is unknown.

As Operation 7, Level 6, Lot 1 was excavated through the next 3 levels (Operation 7, Levels 7, 8, and 9, Lots 1, 1, and 1), these levels have only a single lot for their sealed surfaces and share plot diagrams with Operation 7, Level 6, Lot 1 and Lot 2 (Figure 122). The next plaza surface (Operation 7, Level 7, Lot 1) was reached at 63 cm, although there was a 3-5 cm depth gradation from the northern to southern half of the unit. This level contained pinkish gray soil (7.5YR 7/2), and had a rougher surface than the second floor (Operation 7, Level 6, Lot 2). The sherds recovered from this level belonged to the Early Classic. The plaster surface was 2-3 cm thick, and like the previous level the fill contained *chich*, *sascab*, and reddish pebbles.

The fourth plaza surface was reached at 64 cm (Operation 7, Level 8, Lot 1), and unlike the other floors of this unit was almost completely level. The soil color remained at a pinkish gray (7.5YR 7/2), and the floor was 2-3 cm thick. Beneath the floor was a 15-20 cm layer of pebble fill, with a consistent 5 cm diameter for the stones. The primary constituents were black and red silicified limestone, with accompanying *chich* and *sacab* fragments. Middle Formative, Late Formative, and Early Classic sherds were recovered from this level.

The fifth floor was located at a depth of 82 cm (Operation 7, Level 9, Lot 1). The surface for this level was very poorly preserved, and it was distinguished primarily because it formed a plane beneath the pebble fill under the fourth floor (Operation 7, Level 8, Lot 1). The soil was a pinkish gray (7.5YR 7/2), easily crumbled plaster layer 4-6 cm thick. The three identifiable sherds recovered from this level dated to the Terminal Classic. Another surface appeared immediately beneath the *sascab* layer, although it appeared to be a pause in construction rather than a finished surface.

Operation 7, Level 10, Lot 1 marked a texture change at 84 cm. Although very uneven, it was composed of a lighter and seemingly purer layer of *sascab* than the previous surface, possibly indicating a different source. The soil color was light gray (10YR 7/2), and crumbled easily. These sherds come from a mixed context, with Late Formative and Early Classic ceramics represented in this level. The plaster was laid upon a 15 cm layer of *chich* and small stones. As on previous levels, a 3-5 cm gradient

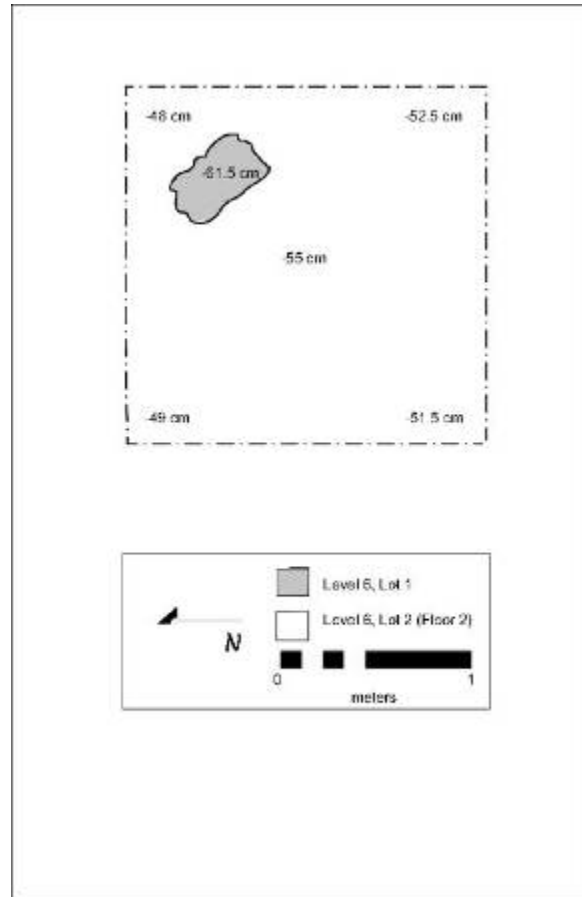

Figure 122. Sisal, Operation 7, Level 6

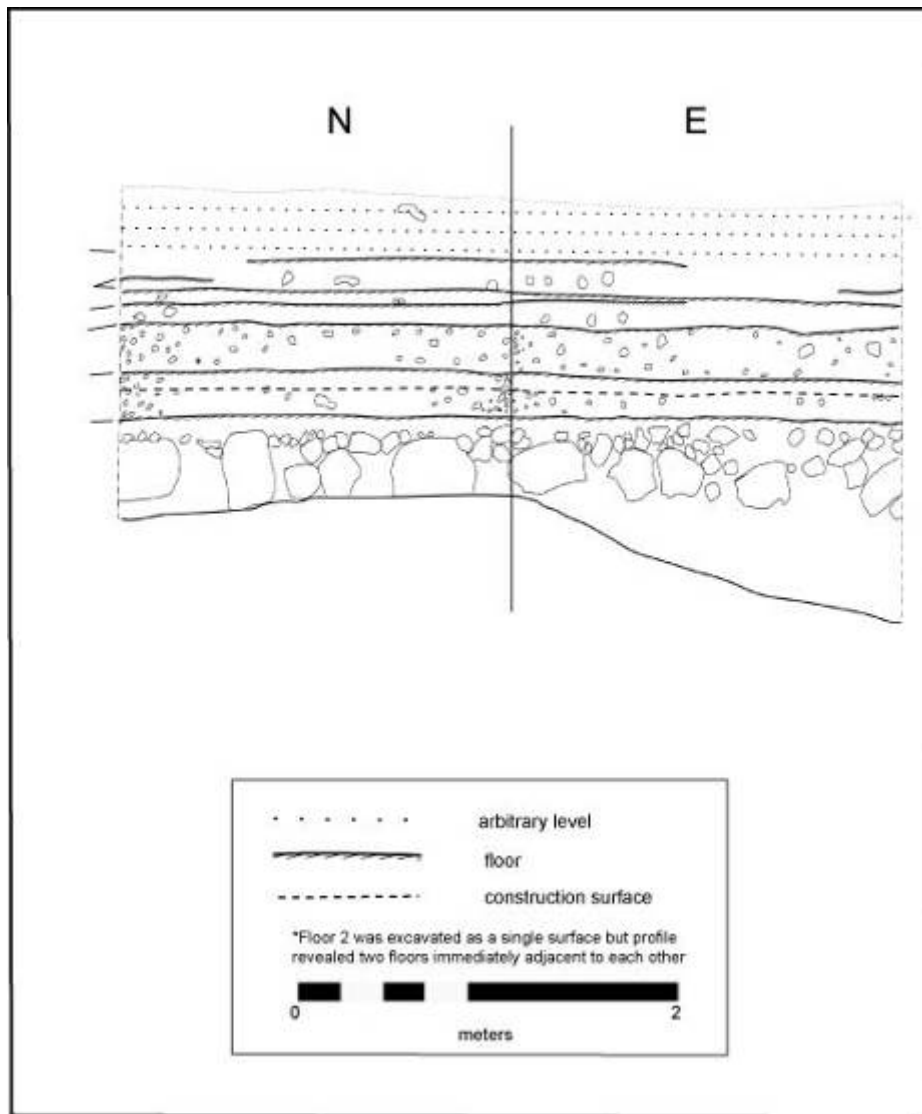

Figure 123. Sisal, Operation 7, North and East Profiles

from north to south was observed.

The final plaza surface of this lot (Operation 7, Level 11, Lot 1 and Lot 2) was reached at a depth of 99 cm. The primary lot of this level (Operation 7, Level 11, Lot 1) consisted of a compromised section of plaster in the southern portion of the unit (Figure 124). The surface soil was white (10YR 8/1), with loose *sascab* pieces overlaying 35-40 cm of dry core fill. The dry core was comprised of stones ranging from 5 cm to boulders over 40 cm in diameter. Immediately beneath the dry core the soil changed to a weak red (2.5YR 4/2), and bedrock was reached within the next 10 cm in the majority of areas. This lot was mixed, with sherds ranging from the Middle Formative (5), Late Formative (10), Early Classic (4), and the Terminal Classic (4).

The secondary lot (Operation 7, Level 11, Lot 2) comprised the oldest intact plaza surface of the unit. The soil was a white (10YR 8/1), relatively smooth *sascab* layer capped over dry core fill and eventually turned to a weak red (2.5YR 4/2) immediately over bedrock. Middle Formative, Late Formative, and Early Classic sherds were recovered from this level.

The findings from this excavation concur with those from the 2005 season (Shaw 2005: 168) that construction in this area of the Sisal site did not begin until the Early Classic. Although mixed lots prevent more precise dating of the individual levels, all six plaza floors appear to have been constructed during or before the Terminal Classic, although a small number of Postclassic sherds attest to continued use of the site. The Terminal Classic date for the latest plaza floor agrees with the initial hypothesis that Structure N1E1-3 was not substantially later than the rest of the acropolis (Shaw and Flores 2008: 185).

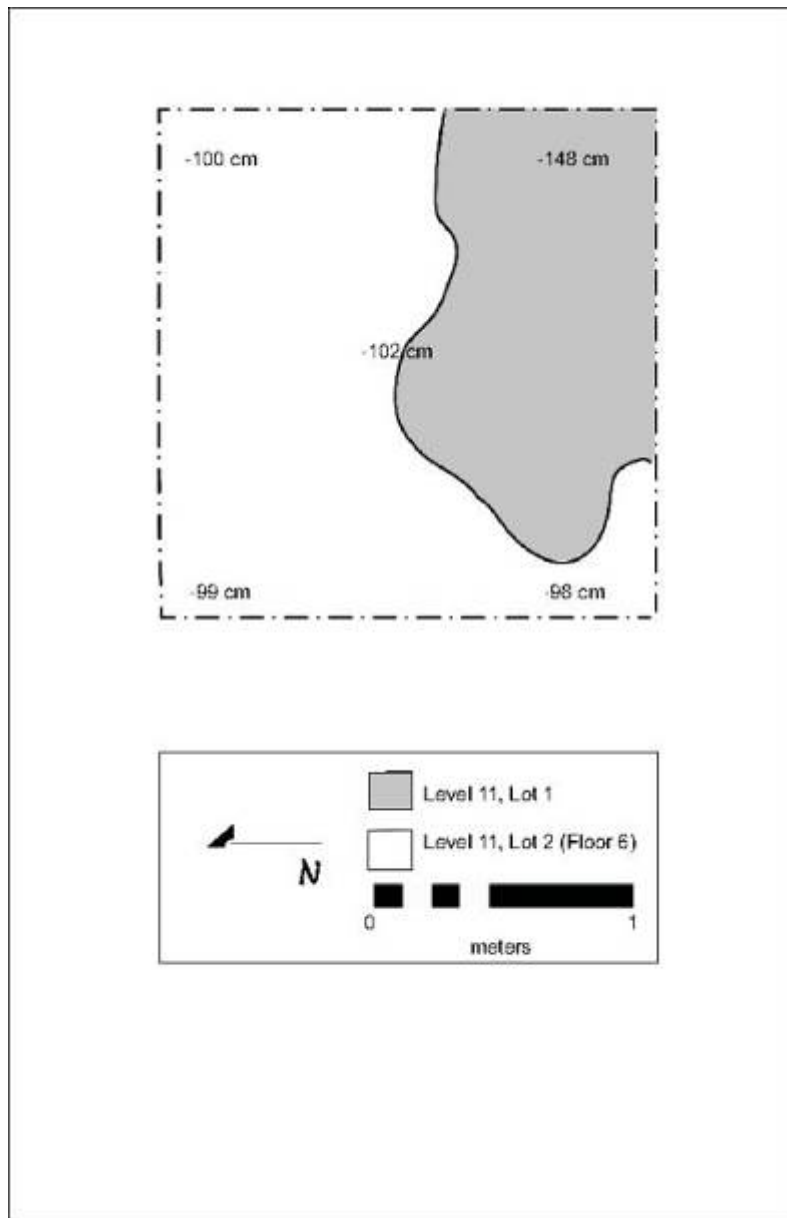

Figure 124. Sisal, Operation 7, Level 11

Part 5: Summary and Analysis

Chapter 46: Under the Foliage of Oblivion: Peripheries and New Sites in the *Ejid*os of Sacalaca and Saban

Alberto G. Flores Colin

This year, as part of the CRAS Project's goals, a brief reconnaissance of certain sites in the *ejidos* of Sacalaca and Saban was carried out. These settlements are of various sizes and have several features, but are distinguished by lying within wooded and distant areas, less known and only frequented by a minority of the inhabitants of these villages. Some of them, such as the Fort of Yo'okop, Ramonal East, X-Kancep and Ya'axche, had been reported previously, both by members of our Project (Flores 2003:70, 2004:199; Kaeding 2008e:45-47, 2008:244-246) and well as other investigators (Martos and Rodriguez 1998). However, these surveys have only been focused on documenting the core areas or those areas with higher concentrations of remains. This year, briefly, we focused on the survey of those areas that are surrounding these sites, in search of more remains to define their extent. Due to certain limitations, mainly time constraints, an exhaustive survey could not be conducted as had been planned; instead only one or two days could be spent working in each one of these settlements. Nevertheless, the information obtained, while not conclusive, opens a new perspective on the role that these sites had within the region, furthermore suggesting lines of research for future seasons. The following is an overview of the different sites visited.

Ramonal Oriente

This site is about 6 km in a straight line northeast of Sacalaca, into the communally held territory of the village. While the settlement has been known to the Project since 2003 (Flores 2003:70, 2004:199), it was not until this season that a topographical record was conducted. However, this was only in those areas with higher concentrations of remains (see Chapter 17 this volume). However, the site is much more extensive than what has been shown in our initial mapping effort, possibly covering an area of about 24 hectares (600 east-west by 400 m from north to south). In total, we located a little more than 20 platforms scattered throughout its surrounding area, although our survey was not extensive (Figure 125). Due to the dense secondary vegetation that exists at the site, the search for structures was conducted using some paths that are mainly traveled by beekeepers or local hunters. From these paths, we also made several perpendicular *brechas*, which also led to the discovery of new structures. Most of the observed structures are low platforms, about 20 x 20 m on average and no higher than 2.5 m, with the exception of a platform located to the west of our map (Figure 125). This platform is about 40 x 60 meters and houses a small mound (about 2 m high) on its northwest extreme. Also, on this platform

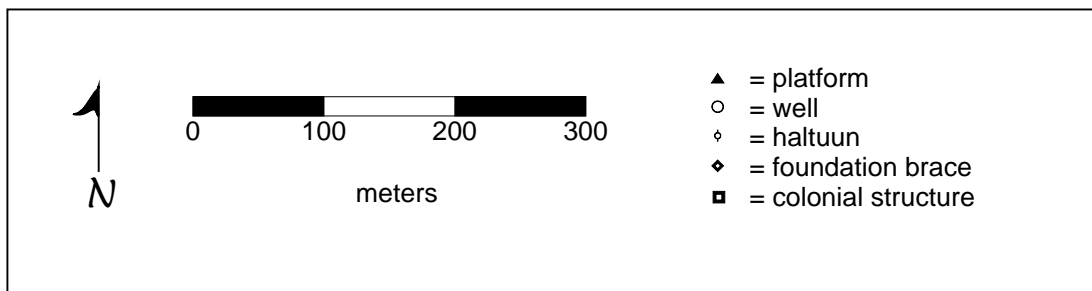
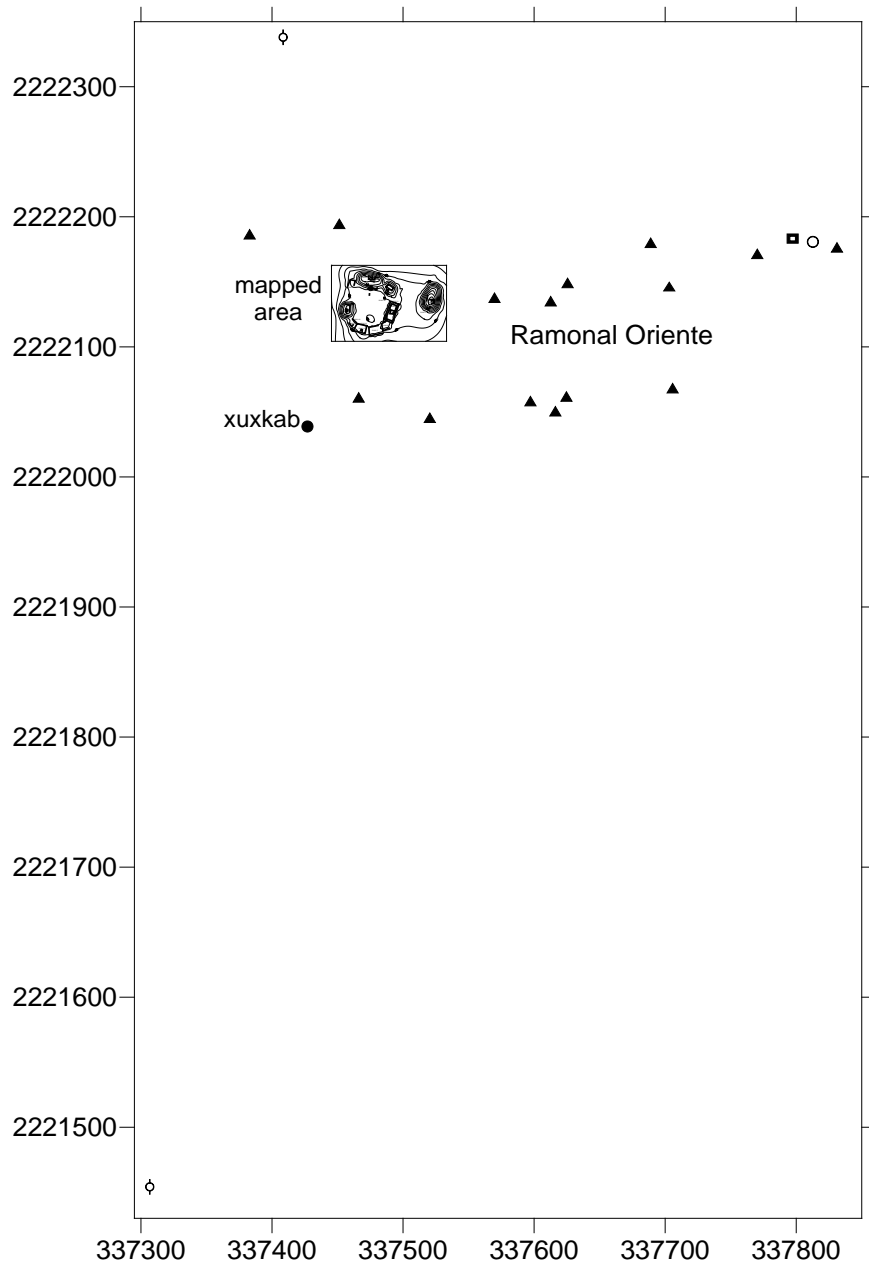

Figure 125. Surveyed Area, Ramonal Oriente, Sacalaca

some fragments of columns and façade elements, reminiscent of the Puuc style, were found. Further south, we were also able to locate the entrance to a *xuxkab*, roughly translated as a silo or tank where corn is stored or a dry cistern (Barrera 2001: 957), which physically is a hole dug in the bedrock, being a sort of small *chultuun*. According to local informants, this feature was used to store and/ or hide grain or food. Furthermore, in the northern part of our route, a *sarteneja* or *haltuun*, a water feature of about 5 x 8 m, was located. This was the largest of these features recorded by the Project until the present.

Fortín (fort) de Yo'okop

This site was investigated by Martos and Rodriguez in 1998 when they conducted excavations in several areas of the military fortification. This year, the Project spent a few days in the topographical registration of many interesting sections (see Chapter 5 this volume). While this process was carried out, a survey crew focused on the location of the limits of the Prehispanic settlement on which the Caste War fortification was constructed. Due to the limited time available to work on the site, and to the secondary vegetation that covers the area, we decided to use some trails and a fence that borders the property on which the fort lies as the basis for the survey. It was decided to strive for greater coverage, sacrificing the detail and systematic survey that would have yielded a more accurate representation. The result of this process was the discovery of about 15 Prehispanic structures of different sizes, covering an area of roughly 27 hectares, 500 m from north to south and about 550 m from east to west (Figure 126). Most of these structures are small platforms of about 5 x 6 m and a meter high that are scattered over a series of terraces that rise both to the north and south of the area where the Fort lies. Besides this, several barricades were located in different sections. According to our local consultants, these kinds of structures continue for several hundred meters to the south of the Fortín de Yo'okop (at least 300 m more). The most interesting feature located in our brief survey, was a range structure (Structure 14 in Figure 126) of about 6 m high and roughly 20 x 10 m. The construction lies on flat terrain along a hillside, possibly an artificial leveling or a terrace. Although no exhaustive reconnaissance was conducted, we examined a circumference of about 15 m around this building, but failed to detect another nearby structure. Vegetation in this area is quite dense, but is still possible that this building is part of a larger plaza complex, a supposition that will be verified in the following season.

Xnichteil (Group C of Yo'okop)

Xnichteil is the name of the forested area where Group C of Yo'okop is located. Group C is connected to Group B through a 1.8-km *sacbe* (Maya causeway). The group was first visited by Wilson in the 1970s (1974:11-14) and members of our Project in 2002 (Lloyd 2002: 21-27). A topographical registration, both of the *sacbe* as well as the terminal structure, was carried out until 2008 by Project members

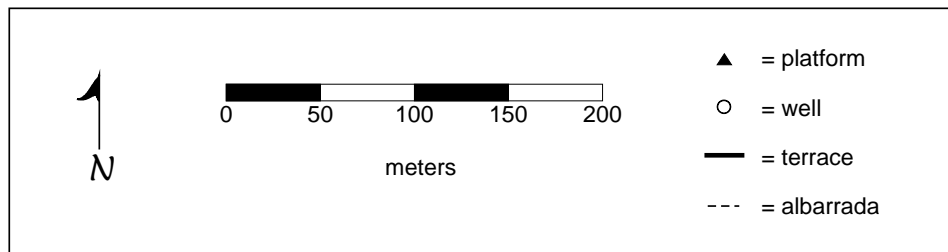
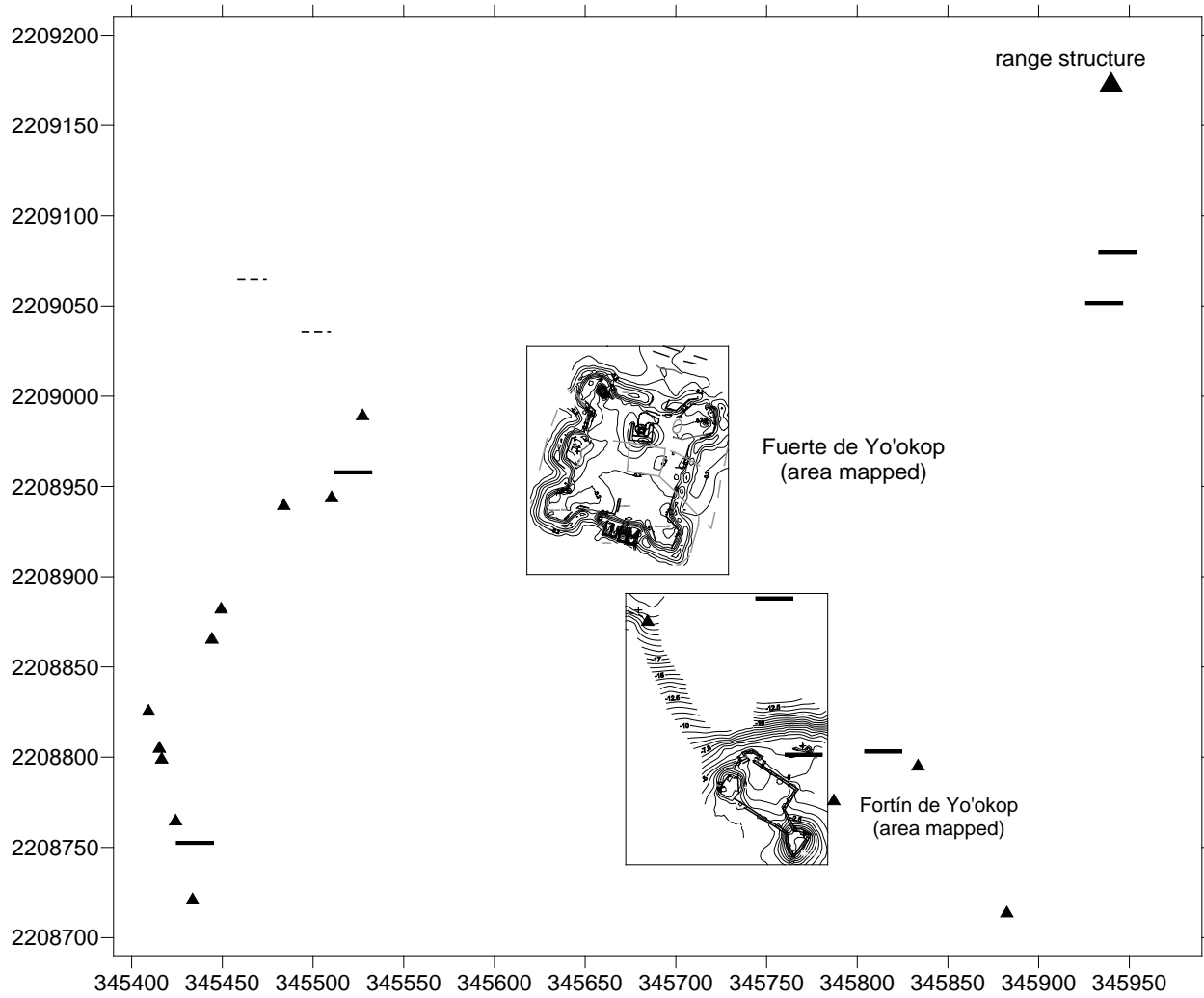

Figure 126. Surveyed Area, Fortín de Yo'okop, Saban

(Flores et al. 2008:9-40). In that year, like previous researchers, we noted and highlighted the relative isolation of the pyramidal mound that forms Group C. A brief survey conducted to the west, north, and south of the mound was not successful in locating other remains (*ibid.*:35). This year, owing to the knowledge of one of our guides, who lived in the area during part of his childhood, we found a large concentration of Prehispanic features. This cluster lies about 650 m southeast of the terminal structure of Group C, in an area known as the well of Xnicleil, where a village existed until the 1970s, when its inhabitants migrated to the modern village of Saban, according to the story told by our local guides (Flores field notes 2010). In total, we recorded about 14 Prehispanic structures, as well as several *sascaberas* and *albarradas*. In general, the structures are about 15 x 10 x 1 m high, although there are one or two larger (20 x 30 x 3 or 4 m high). The area roughly coincides with the latitude where a vaulted passage that perpendicularly crosses Yo'okop's Sacbe 2, which joins Group C with Group B. This makes us think that perhaps the creation of the vaulted passage was because of the population that inhabited the area where the structures were recently located. The passage would allow free movement between both sides of the old causeway, which, in this section, exceeds 2 m height (Flores et al. 2008:9-40). According to our local consultant, in the area there are other platforms but we could not locate them due to time constraints (Figure 127). Vegetation in the area is dense, so reconnaissance takes a considerable amount of time. In the opinion of our informant, the area is good for farming, as there are some sizable *rejolladas* where it would be possible to raise crops that require deeper soils (such as bananas or cocoa). Perhaps this area is where the farmers who maintained the site and sustained the Prehispanic site of Yo'okop were settled.

X-Kancep - Ramonal - San Pedro

The X-Kancep site is located about 13 km southeast of the modern village of Saban. It is accessed by a dirt road leading to the site Yo'okop. From the latter point, the trail runs by roughly 6 km north, until reaching the settlement. This site was reported by Kaeding two years ago (2008:245), but he only reported the presence of a well, which has a very small rim. The walls of the well are exceptionally straight, forming a rectangle that could be almost perfect. Other elements that we saw were two platforms, one to the southwest and one to the northeast of the well, and a apsidal foundation brace further north (Figure 128). Directly to the west, a small *milpa* (cornfield) was found. In this area, there were a lot of ceramic sherds scattered on the surface, too eroded to be identified. Besides the above mentioned, it was interesting to find a pair of *albarradas* that flank a path that goes north to the area known as Ramonal, about 600 m ahead (which we denote as Ramonal Saban to avoid confusion with sites of Ramonal Oriente and Ramonal Poniente in the *ejido* of Sacalaca). These parallel *albarradas* are crossed by others that seem to be defining lots or pens.

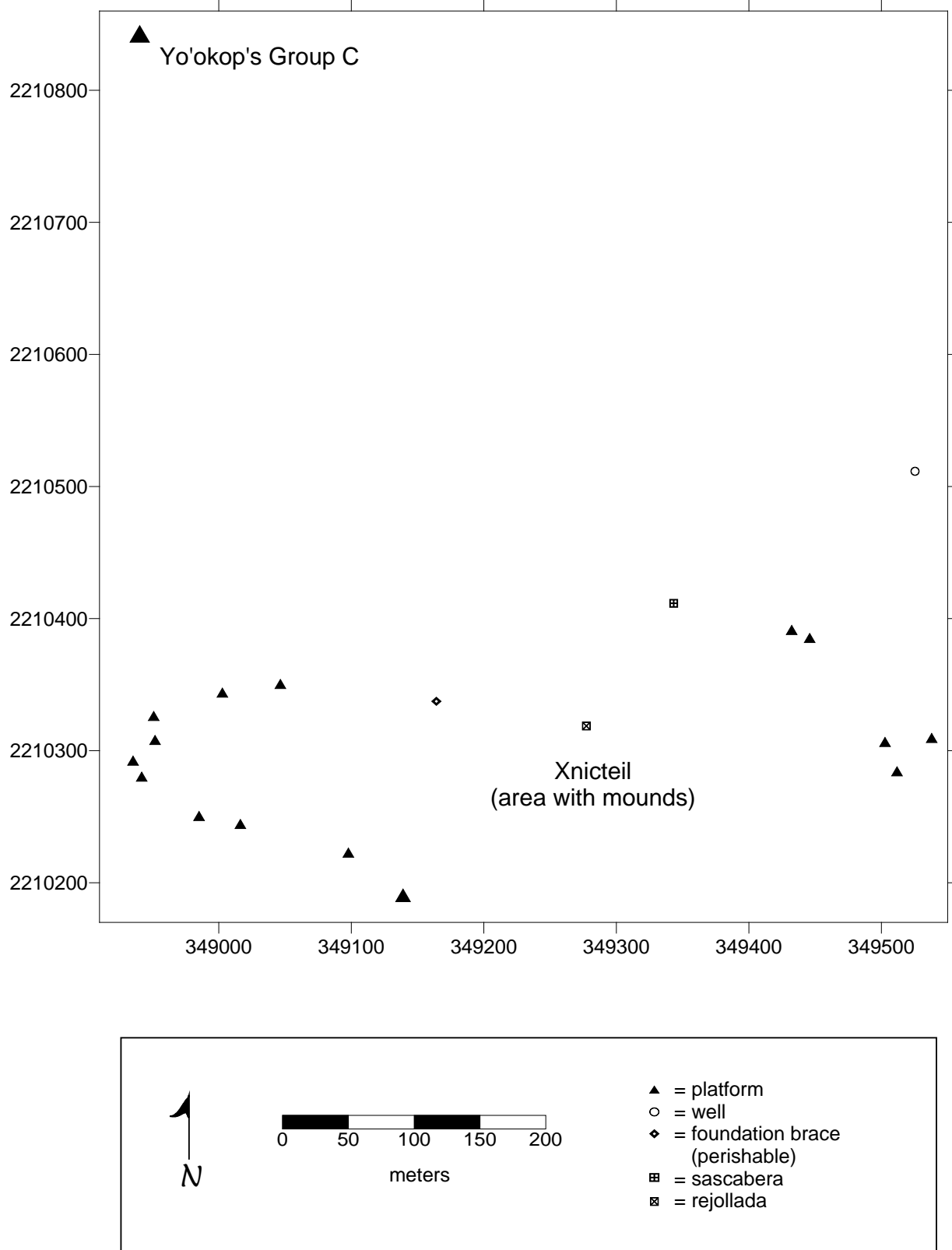

Figure 127. Surveyed Area, Xnigteil-Yo'okop's Group C, Saban

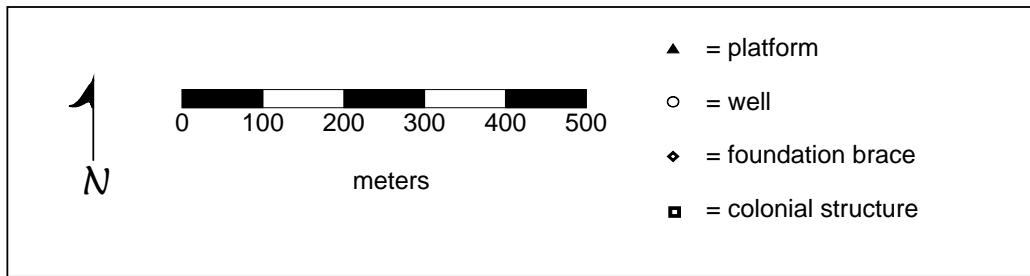
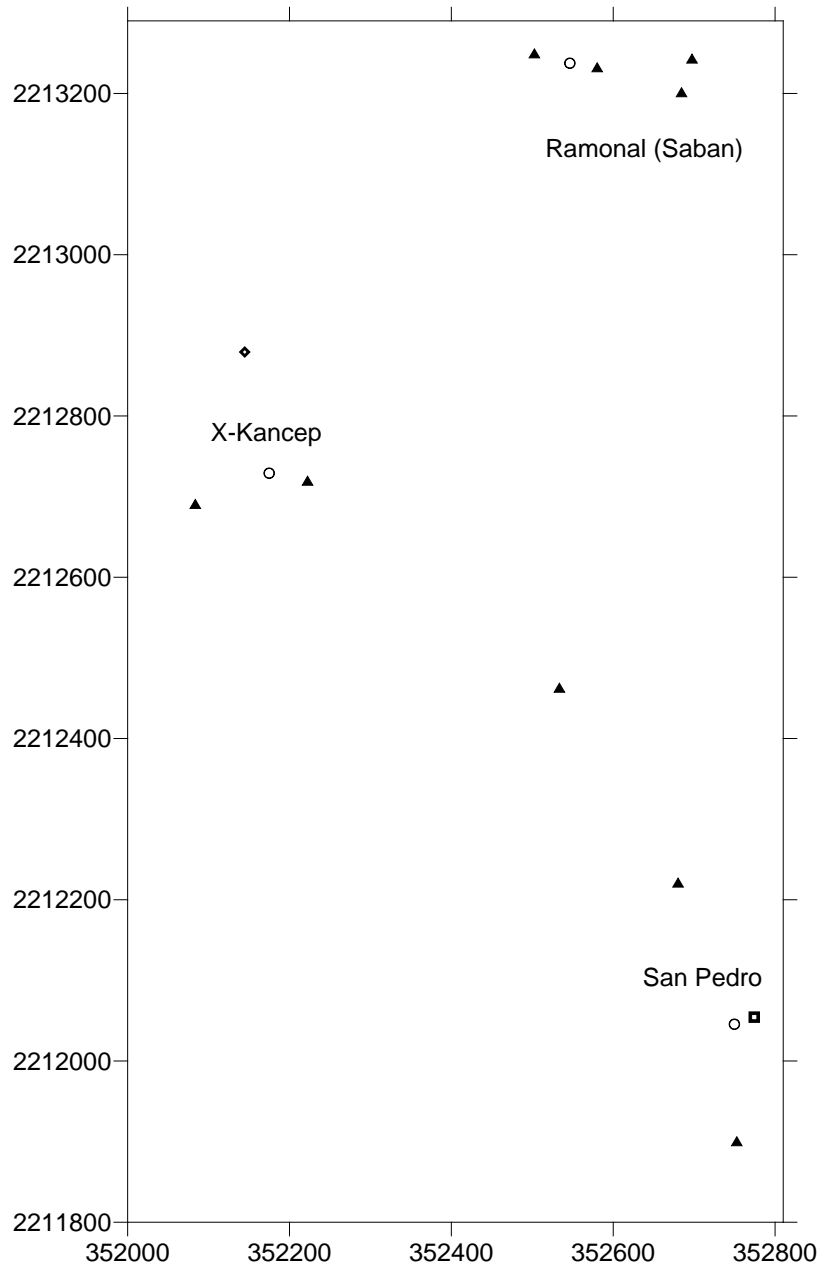

Figure 128. Surveyed Area, X-Kancep-Ramonal (Saban)-San Pedro, Saban

Just where there are a couple of parallel *albarradas*, which appear to form a street and these are connected with others that flank the trail to access this settlement, lies the entrance to the site of Ramonal. A few meters from this junction a well, carved directly into the surface of the bedrock, is located. In addition, five other platforms were located, both to the west and northeast of the well. These structures were low platforms of about 10 x 15 x 1 m on average. On top of one of these, the remains of a *metate* and a columnnette were found (Figure 129).

About 900 m to the southeast of X-Kancep is the site of San Pedro, whose main feature is an old ruined house that was once a farm or *hacienda*. It is accessed by a dirt path, which is also flanked by two *albarradas*, but not along its entire length (Figure 130). Today, the remains of a house with three bedrooms and a water wheel with small aqueducts of about half a meter high can still be observed (Figure 131). Due to the presence of a honey farm right in the center of this colonial-historical complex, we could not adequately review these remains. However, a brief survey on a path to the south, about 150 m from the well, we found a couple of Prehispanic platforms. Also, between the well and the site of X-Kancep, a large platform was located. This building was constructed with 40 x 60 cm boulders, on which there is a circular line of rocks on its northwest corner, probably representing buildings from different periods (Figure 132). To the north of this feature, several *albarradas* and a large *sascabera* were located.

Reconnaissance of all these sites was brief, so this was by no means a comprehensive survey. According to the observed data, Prehispanic settlement is continuous between the sites of Ramonal and X-Kancep, as well as between X-Kancep and San Pedro (Figure 128). We postulate that all these *albarradas* date from Late Colonial or a Pre-Caste War period.

Forest of Ya'axché

The name of the tree Ya'axché (*Ceiba pentandra*, Pennington and Sarukhan 2005: 370-374) is used to designate a large area of roughly 2,000 hectares. It is located in the southern part of the Saban *ejido*, which encompasses wild and agricultural areas, that in turn is also part of a larger area designated as the "reserve," that comprises about 5,000 hectares, recently assigned to the conservation of trees and animals as part of a governmental program. In this forested zone, four different areas with Prehispanic remains (Figure 133) were located. These are designated, by the same locals, as Ya'axché 1 and Ya'axché 2, while the other two have no known name, so we have called them Ya'axché 3 (X-Copó) and Ya'axché 4 (Piim mul).

The site of Ya'axché 1 was topographically recorded this year (see Chapter 14 this volume). Ya'axché 2 is about 3 km southeast of Ya'axché 1, and roughly 12 km southeast of the village of Saban. The site consists of two pyramidal structures of about 6 m tall, lying on a platform of about 30 x 30 x 1 m. There are other smaller platforms in the vicinity, in addition to a well with a colonial or historical rim, that have been recently modified and repaired (Figure 134). These structures are easily observed, because they lie within a cattle corral. No survey was conducted beyond the area cleared by cattle; however, according to the farmer who works in the area, there are other smaller platforms in the vicinity.

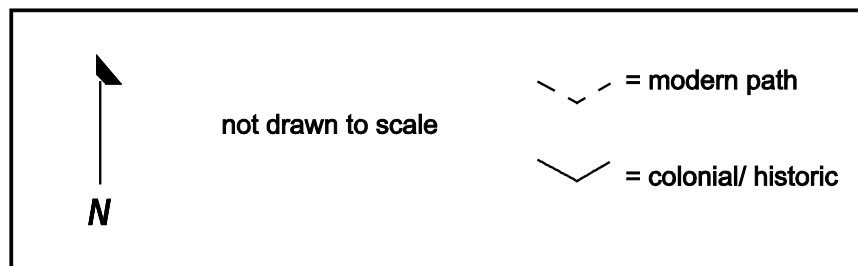
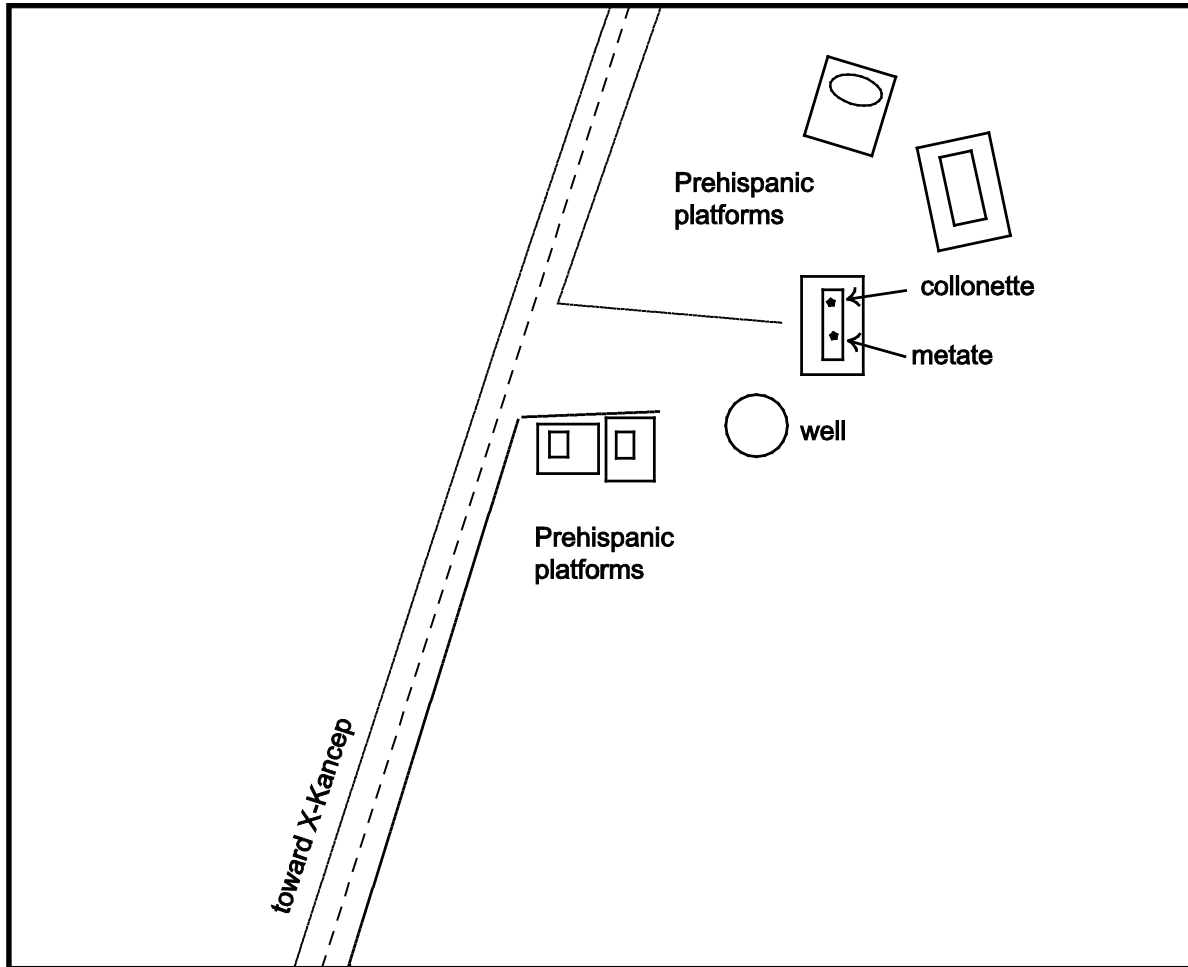

Figure 129. Sketch Map of Ramonal, Saban

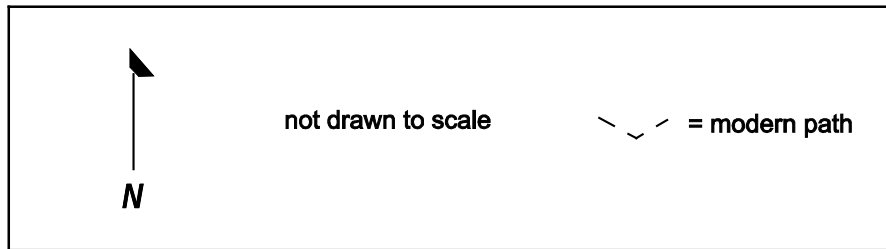
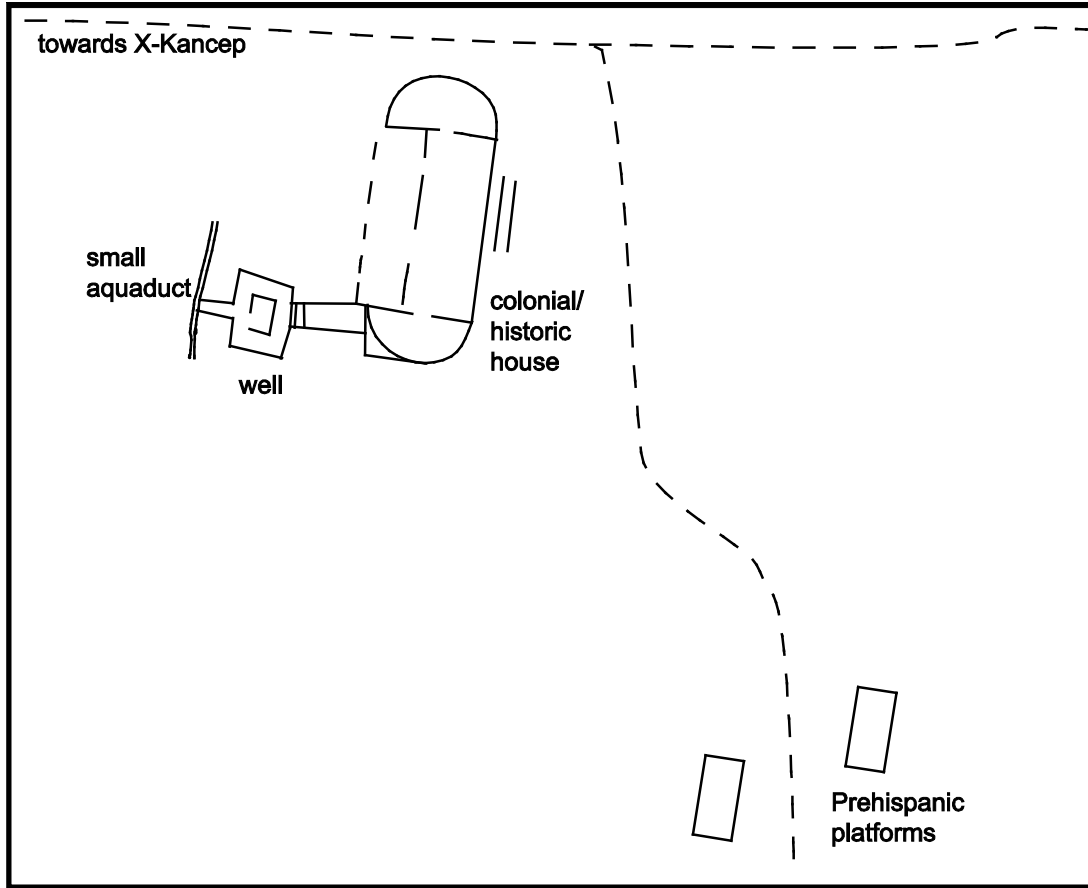

Figure 130. Sketch Map of San Pedro, Saban



Figure 131. Remains of Colonial-Historical house, San Pedro, Saban



Figure 132. Platform between X-Kancep and San Pedro, Saban

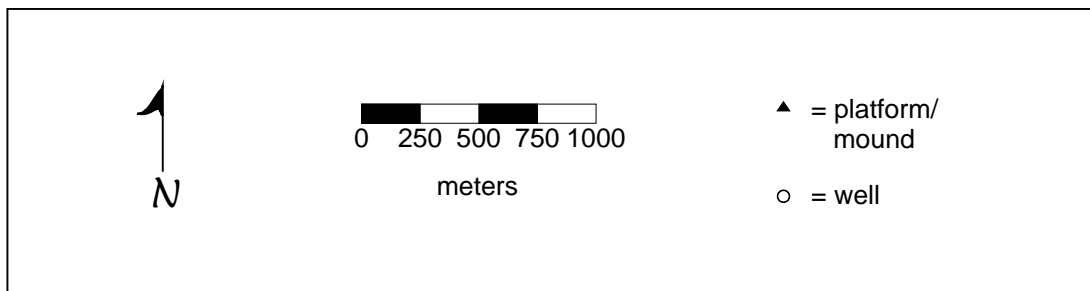
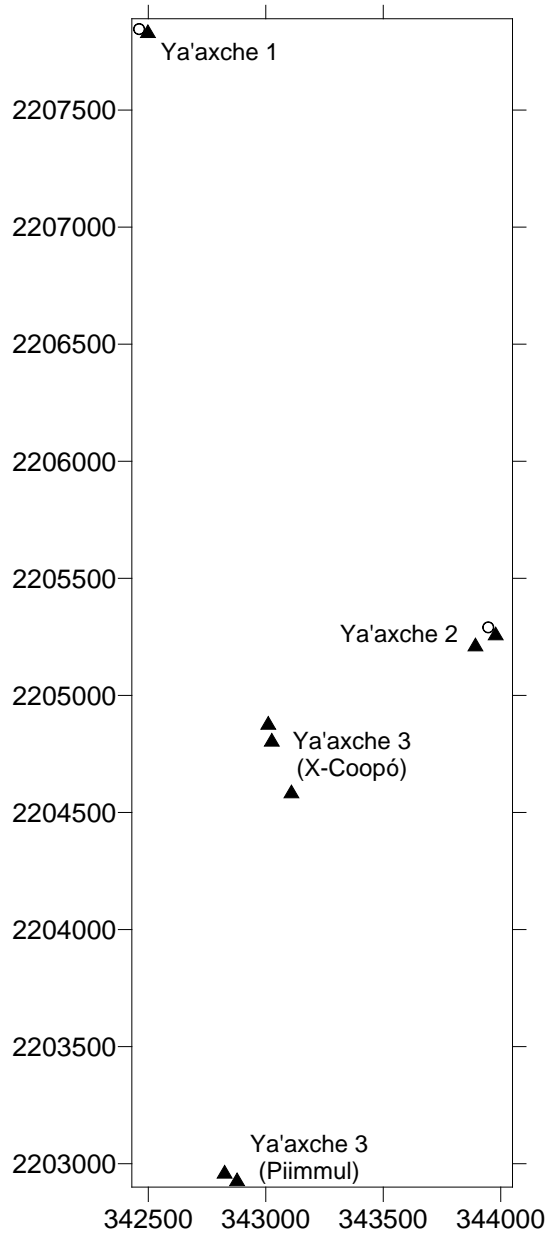

Figure 133. Surveyed Area, Ya'axche Tropical Forest

The site of Ya'axché 3-X-Copó is located within the area known as "the Reserve," near one of its corners (there are 6-m-wide gaps, which indicates its limits), just where a huge Copó tree (*Ficus cotinifolia*, Pennington and Sarukhan 2005: 142-144) lies, whose shape and height stand out in this environment. For this reason, in order to establish a better location for future reference, we have added the name of this large tree to the archaeological description of this settlement. According to our informants, the area where this site lies was previously used for agriculture. Since the creation of the protected area, agricultural areas have been abandoned and today dense secondary vegetation has proliferated. In Ya'axché 3, we could only find two platforms (of about 30 x 40 m), with a pyramidal superstructure (about 3 m high) on their tops. Our informant assured that there are more structures in the vicinity, in addition to an unfinished well. However, we could not find more structures in the area, mainly due to the secondary vegetation that hampered our mobility and visibility.

The last area with archaeological remains visited on this survey of the Ya'axché forestal area, was a place that has no name, but which lies within "the Reserve" of tropical forest. Therefore, we named it as Ya'axché 4-Piim Mul, due to the presence of about 15 small Piim trees (*Ceiba aesculifolia*, Pennington and Sarukhan 2005: 370-374) on its summit, a feature that makes it identifiable for a future reference with locals. It is located about 2 km southwest of Ya'axché 3-X-Copó and around 14 km southeast of the village of Saban. The site is the southernmost site ever recorded in our regional survey. In fact, only two structures were located; a pyramid-like (about 20 x 20 x 6 m) mound and a low platform (around 60 m northwest of the mound), which appears to be a natural outcrop adapted to a cultural use. Although visibility in this area is quite good, as the site lies beneath a high forest vegetation, in a brief reconnaissance to north and south from the Piim mound, we could not locate more cultural remains. Thus, we assume that the settlement may continue to the east or west of said mound. It has to be noted that, according to our local guides, there is no colonial or historical well known in this area. Therefore, it is probable, at least, that this site was outside of the zone of influence of the colonial and/or historical village of Saban. Perhaps this site was already within the former area of "*la Montaña*," a forested area unknown and unexplored during colonial and historical times, where the Spaniard -and later Mexican- control, was ephemeral or non-existent (Bracamonte 2001: 26-29).

Old Questions and New Perspectives

As has occurred throughout our research in the Coahuah Region, the discovery of these remains has left more questions than answers. Therefore, only initial hypotheses can be raised. Based upon surface data, we speculate that the site of Ramonal Oriente was a quite extensive settlement and it seems that a considerable terrain is full of low platforms. Its larger vestiges do not have sizeable dimensions (less than 3 m in height). It seems that this site is the largest settlement in the northeastern part of our current study area, but a further survey, as well as more systematic coverage, is needed to confirm or refute this assumption. The settlement is separate from Yo'okop, Ichmul, and Sacalca, the largest sites within the region. Therefore, it seems probable that this settlement was autonomous or perhaps was related to another



Figure 134. Mound at the Site of Ya'axche 2, Saban

nearby settlement to the east, but this can only be hypothesized since Ramonal Oriente is the easternmost known site into the Sacalaca *ejido* at present, and therefore the most eastern of our archaeological surveyed area.

Prehispanic structures of the Fortín de Yo'okop, as well as those of Xnicleil, could be part of the same extended site of Yo'okop, although they also may have been isolated settlements if they were not contemporaneous. The former is located 1.9 km northwest of Yo'okop's Group A, while the latter lies 2.7 km from the same group, but only 650 m from Group C. It would be interesting to conduct a series of excavations to investigate if these settlements are contemporaneous with Yo'okop, and corroborate or refute whether these were part of a single and extended settlement.

The forested area known as Ya'axché and "the Reserve" that form a huge area is the most forested area in the *ejido* of Saban (due to its distance, only a few hunters venture into this woodland). Archaeologically speaking, this larger area is practically unexplored when compared to the eastern or northern area of the same *ejido*. Likewise, this zone is one of the most interesting, since it is still possible to find, if indeed it has been outside of the post-Columbian occupations' influence, sites with little-to-no impact from later cultural activities. However, mainly because of its remoteness, this extensive area also presents diverse logistical challenges that must be resolved to continue with its research in future.

Surveys at these sites highlight again several questions, mainly theoretical, that the Project has had in recent years, such as determining the boundaries of a settlement, as well as the site's relevance and the consideration of what elements or features should be included to create a suitable site hierarchy. Sites such as Fortín de Yo'okop and Ramonal Oriente (considering their Prehispanic components), must have had extensive residential areas, perhaps where most of the population was located or, perchance, where the less privileged social strata resided.

It is impossible to conduct an extensive documentation of all sites. It is not even possible to be able to document all settlements within the region, since there are always unknown and inaccessible areas, even for locals. Conducting a systematic survey of this vast area it is also not feasible. However, it is possible to carry out surveys in the sites' peripheries, through GPS reconnaissance, at least to get a better idea of the extent and characteristics of the settlements. We know that our methodology, based on local informants, has biased our settlement sample. Many of the foundations braces and isolated platforms in the cores, as well as the peripheries, of several sites are not suitably recorded. Although in many cases we know that these remains are spread over large areas of the region, no detailed documentation has been carried out due lack of time. Future surveys should try to reduce this lag, at least as long as time permits. However, this first approach to the Coahuah region makes us to consider the complexity and abundance of settlements that existed in the past in an area that usually is a blank spot on the most utilized archaeological maps.

The Project intentions are, year after year, to extend the registration of new sites and document them, at least partially, with surveys like this that include the main characteristics of the settlement. Although our map (Figure 2) has been filled with various "constellations" of sites, there are still some blanks and unknown areas of significant size that remain unexplored. With the advancement of our research, the knowledge of the region will grow. Undoubtedly, many remains on the periphery of

settlements, as well as other sites now unknown, will remain, for a few years, without a relevant documentation, hidden in the dense tropical forest, under the foliage of oblivion.

Part 5: Summary and Analysis

Chapter 47: Documentation of Water Wells in the Coahuah Region

Jorge Pablo Huerta R.

"What we know is a drop of water, what we ignore is the ocean"
Isaac Newton

Water is the essential liquid for life; therefore is a critical resource to civilizations. In our archaeological research in the region, several remains of features and artifacts related to surface water and groundwater have been found. Most of these sources are underground aquifers that are accessed through wells dug from the surface, which, in most cases, are related to Prehispanic and historical features. In this chapter, we begin by describing some of these water features, with the primary intention of providing data for future research.

Because of its origin (INEGI, 2009: Maps 2-5, 8 and 10), soils within our study area are dominated by limestone with high permeability, allowing water filtration to the inner layers resulting into a high abundance of groundwater. Access to these aquifers is through natural caves and *cenotes* (sinkholes), in addition to excavated wells (of cultural manufacture).

This chapter describes only some of these cultural sources documented by the Project. A well is not a simple pit in the surface; instead it can be seen as a structure that includes several functional requirements for extraction and water usage. Although we have a lot of data from this season, in future years we plan to make a classification that considers various aspects such as morphology, construction phases and modifications, and how the water table is accessed. Likewise, with data from future seasons we plan to answer some basic questions such as temporality, manufacturing techniques and whether or not certain surface indicators determined their location and construction. Although currently we have a good sample (21 wells), yet to be recorded in detail are the majority of the wells known into our surveyed region (over 88). At the present, we only focus on the description of some of the features studied in 2010 that lie within the *ejidos* of Saban and Sacalaca.

The Road to Sacalaca- Ramonal Poniente (Sacalaca)

This well is located near the road leading from Sacalaca to the site of Ramonal Poniente (1.3 km southeast of the village). Only a few *albarrada* sections were located in the vicinity of the well. Although we assume that there must be a Prehispanic or historical ruins in the vicinity, due to time constraint reasons, it was not possible to conduct an exhaustive reconnaissance.

This well has a rectangular curb, with rounded corners (being the only example known at the region). It measures about 1.8 x 1.6 m. The curb height is 20 cm, while the thickness of the walls is 30 cm. Today, it is dry and clogged; the bottom is 24 m deep. In the southern area of the curb, a wooden cross is embedded, which was used

as support to draw out water from the interior. The exterior still has a somewhat rough plastered surface.

Its interior walls are divided into two sections. The first one goes from the curb to 80 cm deep, and consists of stones set in mortar. From this point on to the bottom, the well was dug directly through bedrock.

This well is probably the result of three construction phases. The first was when the bedrock was excavated to reach the water table; after that several stones with mortar were added to reach the surface. Its last phase must have occurred when the curb was built, in addition to the crossbar and the plaster.

Chuunpich

This site is in the *ejido* of Saban. Its well is located to the southwest of the low platforms mapped during this season (see Chapter 4 this volume). Both to the west and northeast of the well are remnants of *albarradas* that belong to the old ranch. The well is dry and its bottom is about 20.6 m depth. Its curb is round (2.80 m of its exterior diameter). The thickness of its walls is 40 cm and it is around 80 cm (Figure 135) tall. The well still has a plastered surface both outside and on top, but this is in poor condition.

The well's internal structure is circular. Interior walls are divided into two sections; from the top of the curb to around 6 m depth it is constructed with well cut stones, placed side by side without mortar. From this depth, the well conduit is reduced to about 40 cm. The rest of the well does not have a plastered surface, but was carved directly through the bedrock.

This well probably had two construction phases, one when it was excavated, perhaps at the bottom of a natural depression and directly through the bedrock, while the other occurred when the stone walls without mortar were laid to form the top of the well. The plaster that covers part of the curb could be from recent times, when it started to be re-utilized by contemporary settlers.

Northeast Group of Sacalaca

This well is located 2.3 km from the town of Sacalaca, along the Sacalaca-Xquerol road and close to the called "Northeast Group" of Sacalaca (Shaw et al. 2003:40-54). Because this cluster of Prehispanic vestiges is the nearest group to the well, we have designated it with the same name but this doesn't mean that they are contemporaneous or were part of the same settlement.

This well is different from those observed in the rest of the region because it lacks a curb, is narrow, and was carved directly into the bedrock. Currently it is dry, and has collapsed material in its bottom. At present, the bottom of the well is at a depth of 6.5 m (Figure 136). The shape of the curb is circular (1 m in diameter).

This feature is probably the product of a single construction phase and might have been left unfinished. Another possibility is that has actually been completed, reaching greater depths, but is currently blocked by debris.

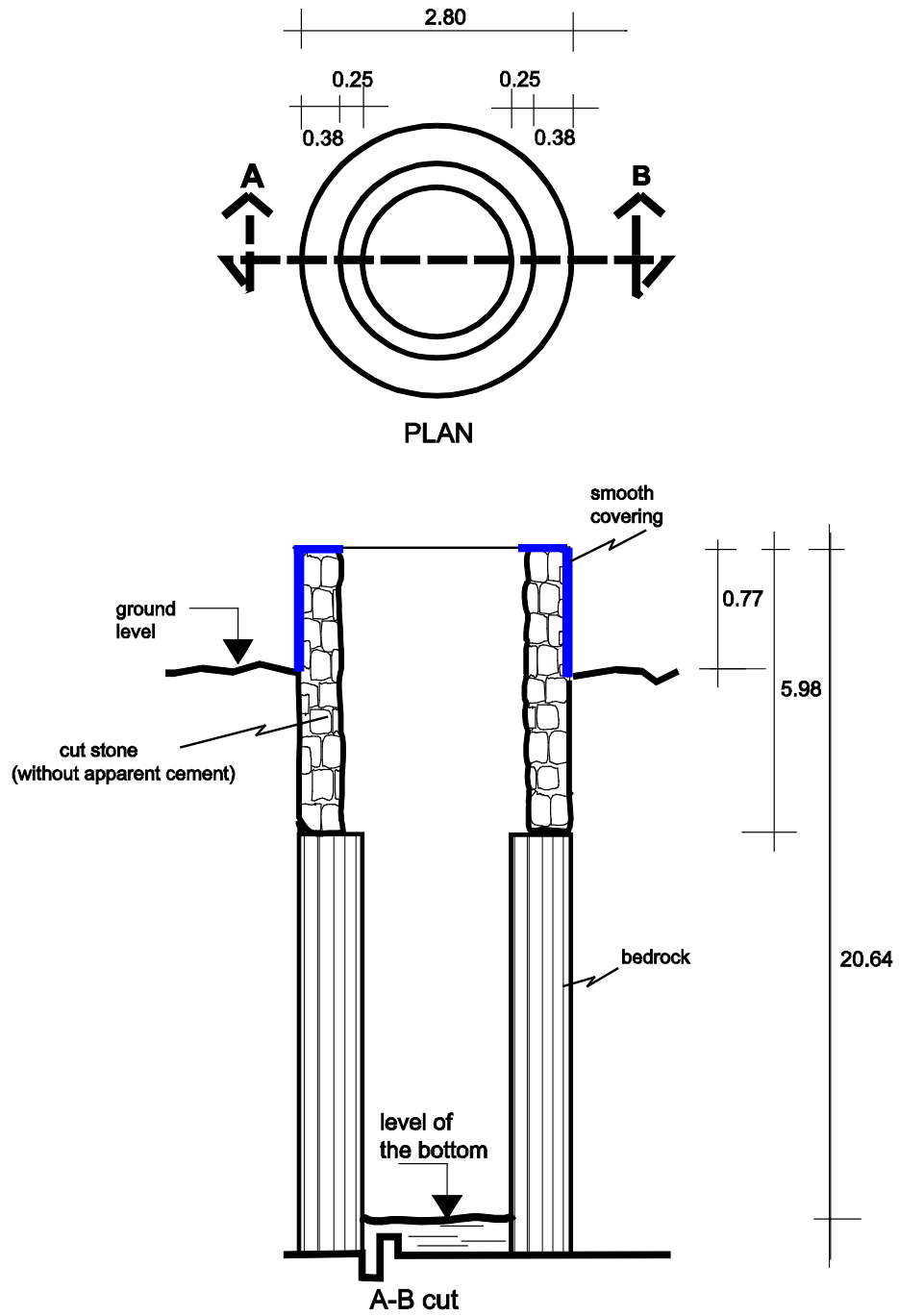

Figure 135. Sketch Map of the Well of Chuunpich

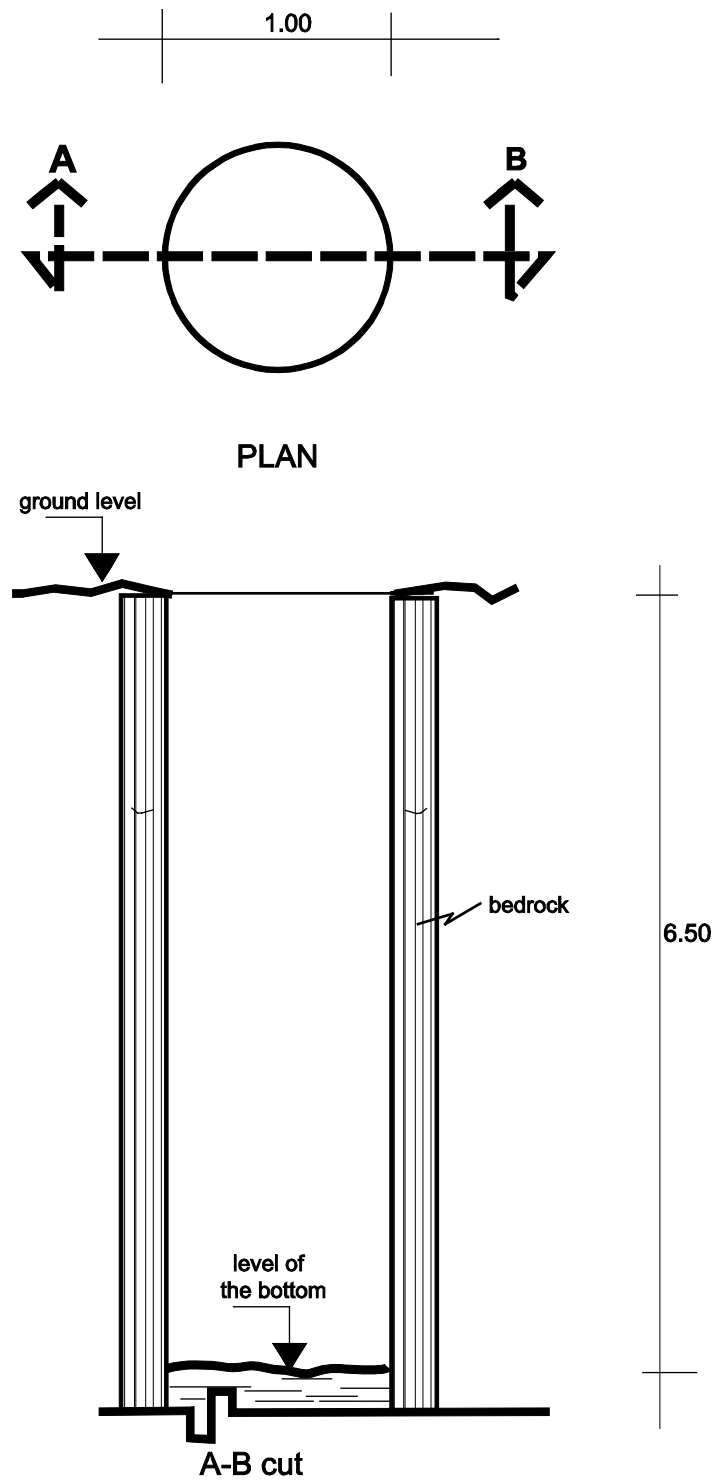

Figure 136. Sketch Map of the Well of the Northeastern Group of Sacalaca

El Palomar

The site of El Palomar is located at 17.3 km southwest of the modern village of Saban. To the northeast and southeast of the well several Prehispanic platforms are located, which were mapped in this field season (see Chapter 7 in this volume). To the north, a rectangular water trough is found; it has an opening that probably was connected to the well through a drainage. The water table is at 16 m deep (Figure 137).

The curb of the well is circular in shape (about 2 m diameter); its walls are around 50 cm thick, and it is half meter tall. It is plastered on the outside, on the top, and on the interior walls. The plaster is relatively well preserved, as is the whole well itself.

The internal structure of the well is also circular and divided into two sections. The portion from the mouth of the curb until 6 m below the surface is composed of stones laid without mortar; from this point the well was carved directly through the bedrock until the water table was reached.

This well was probably built in two phases. The first was carved directly into the bedrock and the second occurred when the stone walls and the curb were placed. This well is still in use by local farmers.

Ixbaquil

Ixbaquil is located at 7 km to the northwest of the modern town of Sacalaca. In previous field seasons, this settlement was visited by Project members (Kaeding 2008f:93-97). It was not until this season when the site was mapped (see Chapter 15 this volume).

The well is surrounded by the remains of an old ranch, while the Prehispanic ruins are located 42 m from its curb. The well is located over a *cenote* (sinkhole) or cave; therefore its roof was used and adequate for the construction of the walls of the well. The water table is at a depth of 21.6 m, but it seems that the water depth is not much, only approximately 20 cm. Therefore we suppose that it's a pool (Figure 138). This well has a wooden framework from which hangs a pulley, and it is connected through a drain with a water trough.

The curb is rectangular (about 2.8 x 2.2 m), and around 80 cm above the surface. The thickness of its walls is close to 60 cm. The feature still has a plastered outer surface that extends to the top and interior walls. Said plaster reaches more than one meter deep, and is still well preserved.

The inner walls of the feature have three sections. From the mouth of the curb until 1.3 m deep is the above mentioned plaster. From this point and to 2.2 m deep, it has several stones placed with mortar. The rest of the well until it reaches the roof of the *cenote*/cave (about 3 m more) is only bedrock.

Therefore, we assume that this well has four phases. The first was when the well was excavated until the *cenote*'s roof. It is possible that a natural passage had been widened. A second phase occurred when the stones were added with mortar. The third phase was when the curb was built and the wooden frame was placed. A fourth phase could have occurred when it was remodeled for its current use, when it was coated with plaster.

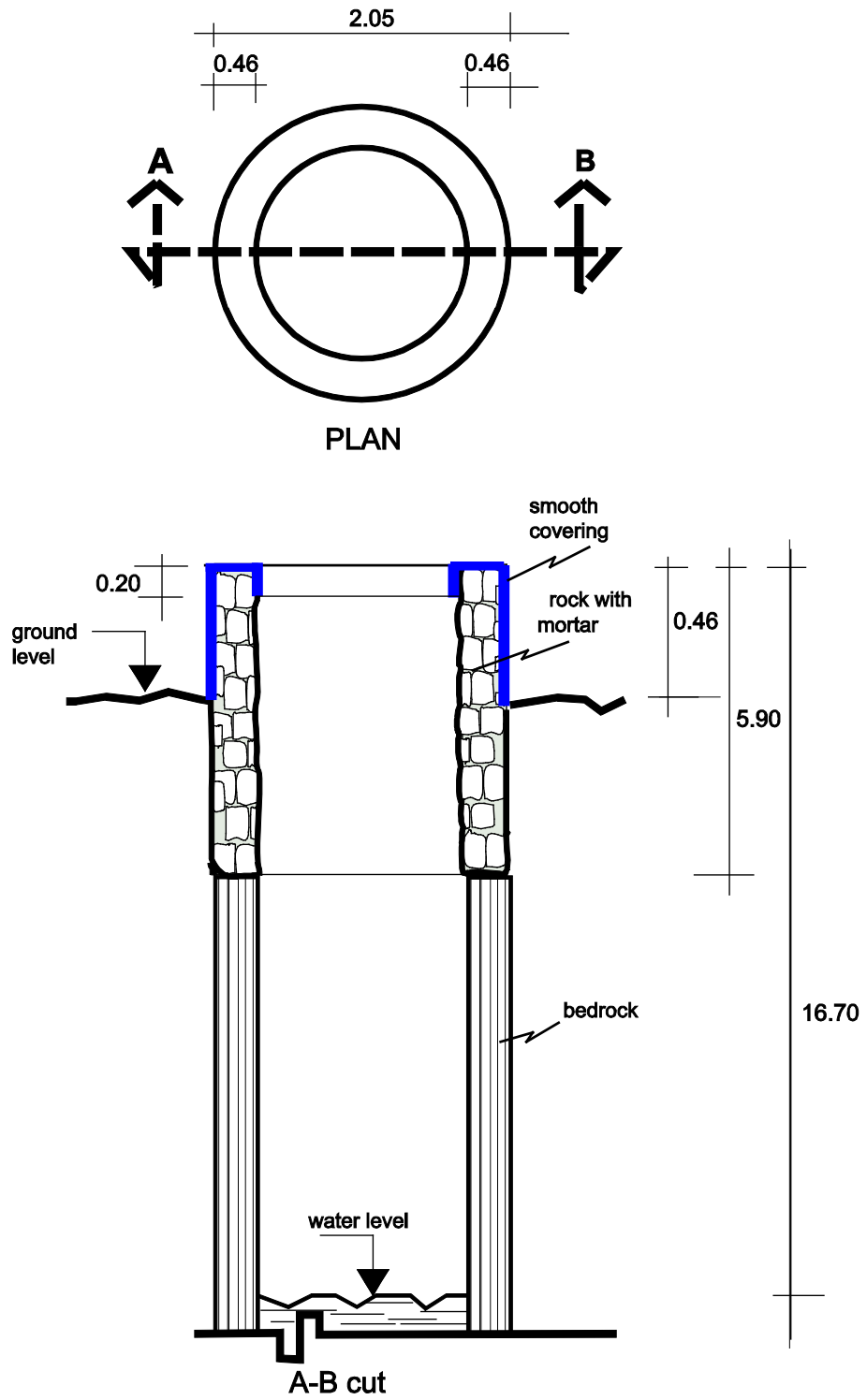

Figure 137. Sketch Map of the Well of El Palomar

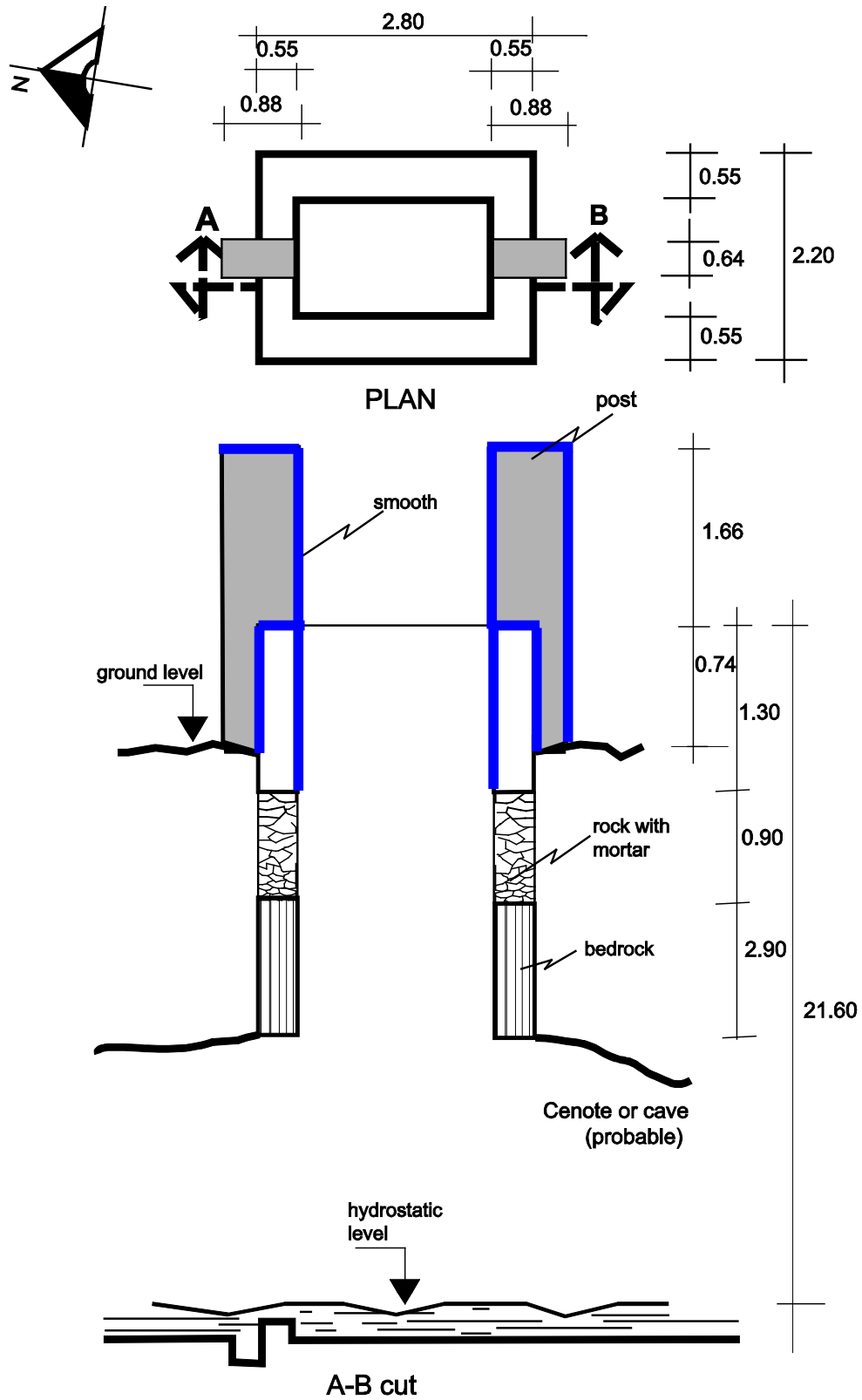

Figure 138. Sketch Map of the Well of Ixbaquil

La Esperanza

The site of La Esperanza is located about 10 km northwest of the modern town of Sacalaca. The area is surrounded by secondary vegetation. The settlement was topographically recorded this season. Prehispanic structures appear to date to the Terminal Classic (Figure 139). Quite recent looting activity was observed in several structures. The well is located to the west of the settlement, about 40 m from a pyramidal structure. The well did not have a curb and is currently covered. No water table was noted, although its bottom is at 25 m depth. The well passage is rectangular in shape (about 3 x 1.7 m). Its inner walls have two sections. The first consists of stones held with binder (reaching 2 m depth), while the second, which is only carved bedrock, is from that point to the bottom.

Therefore, we suppose that this element is the result of three constructive phases. The first was when the bedrock was carved, until it reached the bottom; the second occurred when the stones with mortar were added. The third phase occurred when some stones were placed (including a colonial or historical façade stone) on the inner walls of the well. This modification could have occurred when the well was prepared for a recent use.

La Trinchera

Between the modern village of Saban and the Fortin de Yo'okop lies the site known as La Trinchera (the Trench), about 5 km southeast of the road. The site belongs to the Caste War period. In this place, the vestiges of an old ranch and a series of trenches are located. These constructions were used against the Maya Rebels during Caste War; the ruins were mapped this season (see Chapter 12 this volume). Today, the site has been reoccupied by farmers as workstation; in the vicinity of the old ranch, sowing and beekeeping activities are carried out.

The well curb has poles and a crosspiece that supports a pulley to facilitate water extraction. According to our informants, the well was cleaned about 8 years ago in order to be used. From its interior, several "Winchester" blank cartridges that date to the Caste War were recovered. Approximately 50 m to the west of the well, the remains of a fortification and several trenches are located; these also date to the above mentioned period. The well reaches the water table at roughly 20 m deep (Figure 140).

Its curb is circular, measuring 1.3 m in diameter. The walls have a thickness of about 30 cm extend for a height of 60 cm above the surface. It still has exterior plaster, as well as plaster in the upper parts of the interior, and is well preserved.

The inner walls of the well were constructed differently. From the mouth of the curb to 2.3 m in depth, it is composed of stones set with mortar (although in the first 50 cm the mortar seems to be recent). After this point, and until 4 m deep, the stones are laid without mortar, while in the rest of the passage to the water table the walls were carved directly out of bedrock.

According to the observed data, we can suggest that this well had five phases. The first part of the excavation was directly into bedrock; the second occurred when the stones without mortar were positioned. A third phase was when the stones with mortar were placed, while the fourth was when the curb was constructed. The modifications that conditioned the well for its reuse can be considered as the last phase.

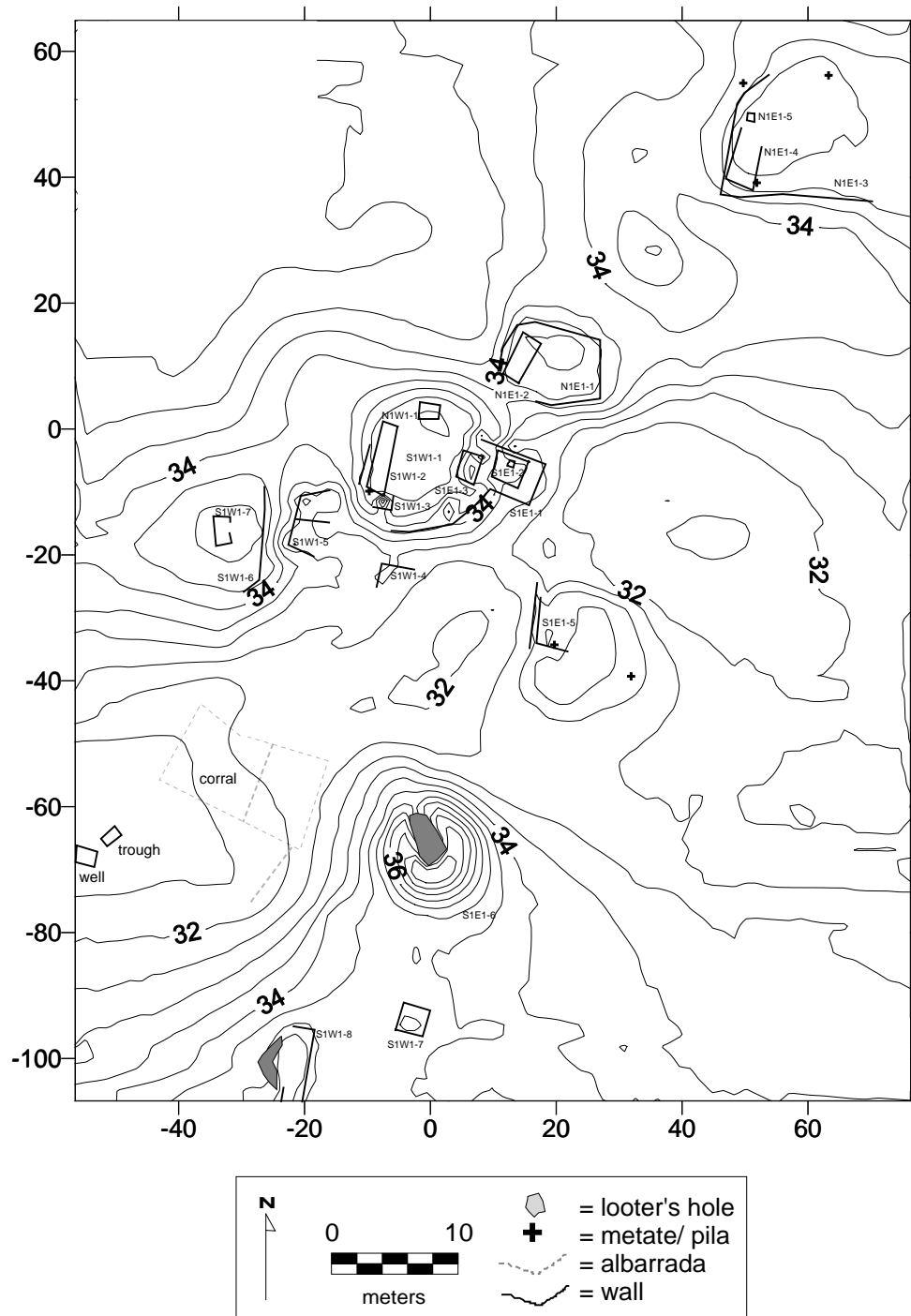

Figure 139. The Site of La Esperanza

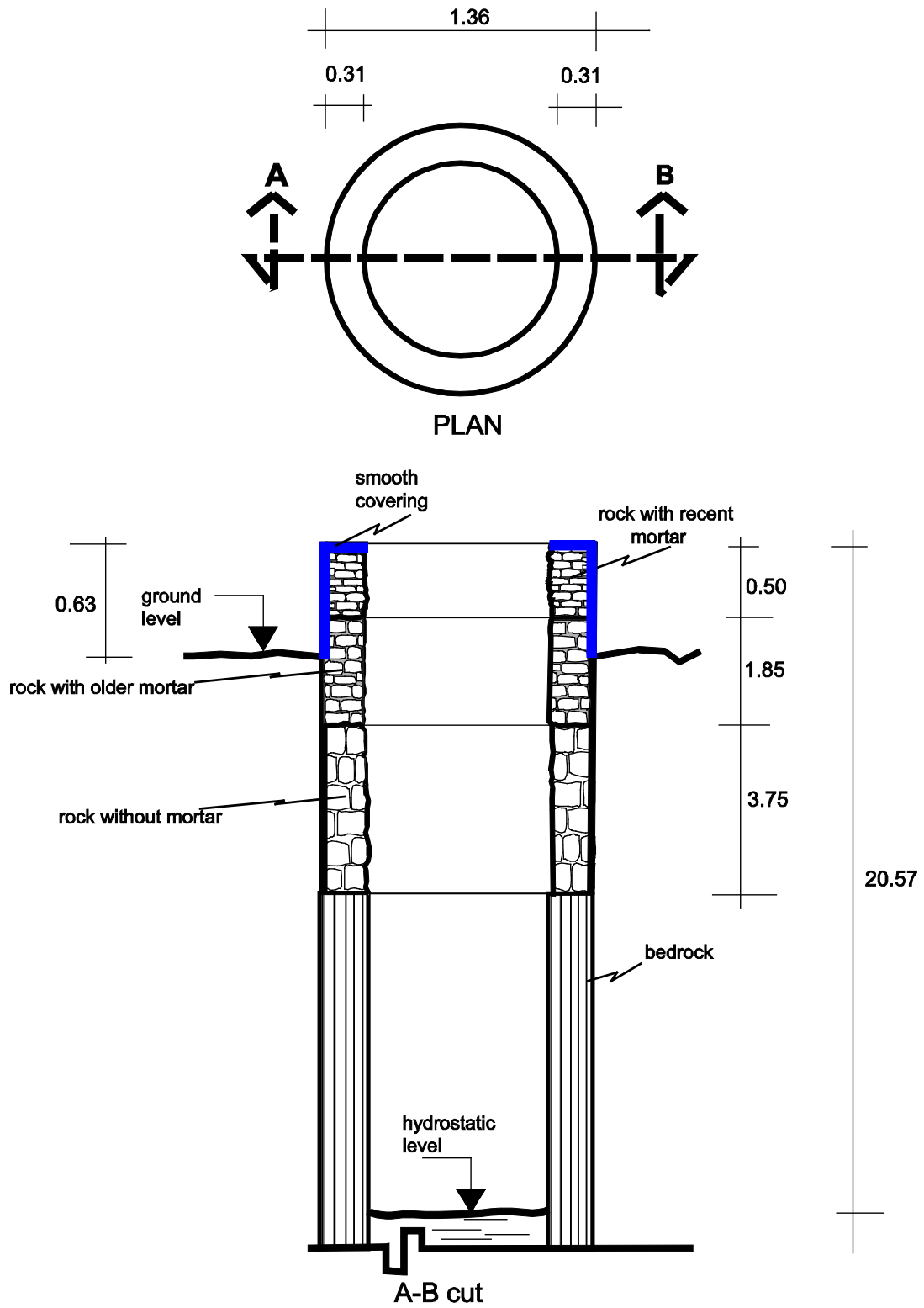

Figure 140. Sketch Map of the Well of La Trinchera

Parcela Escolar

This settlement is located 1 km northwest of the town of Sacalaca. The site has been focused by Project members in several seasons (Kaeding 2008g:94-98; Young 2008:107-114).

Its well is almost circular in shape, dry, and clogged. The bottom is at 23 m deep. The curb is 1.4 m in diameter, 20 cm high, and about 20 cm thick. The stones that compose it do not have mortar (Figure 141).

The chamber of the well consists of three sections. The first one goes from the curb until 90 cm in depth; the stones of this section were placed side-by-side without mortar. From this point until 3.6 m deep, the stones are placed with mortar. The last section was directly carved through bedrock.

We assume that this feature has, at least, three construction phases. The first was when the bedrock was carved to create the well and the second occurred when the stones with mortar were added. This was followed by the stones without mortar and a small curb. There no evidence that the feature has been used in recent times.

Ramonal Poniente

The settlement is located around 4 km from Sacalaca. This site was first registered by the Project in 2004 (Flores 2004: 194-208).

The well is located to the south of the modern ranch on a platform with well cut stones perhaps re-utilized from the nearby Prehispanic structures. The feature has a rectangular shape; the walls of the north and east sides are in poor condition. On its central part, are still the remains of a pillar. The water table is at 27 m deep (Figure 142). The rectangular curb (about 2.3 x 1.6 m) is poorly preserved; its walls are only about 60 cm high, although in some sections retain only about 20 cm of material. The width of the walls is about 40 cm.

The interior walls consist of three sections. From the top of the curb, until 5 m deep, stones were placed with mortar. From this point until a depth of 12 m, stones lie without mortar. The rest of the passage until the bottom is carved bedrock.

According to these data, we speculate that the well may have been built in four phases. The first phase was when the bedrock was carved until it reached the bottom of the well. The second would be when the stones without mortar were positioned. A third phase occurred when the stones with mortar were placed and the well curb and pillars were constructed. The last modifications could have happened when the well was cleaned and re-conditioned by the contemporary inhabitants, perhaps when the wooden beam was added.

Sacalaca, North Well

This well is located in the northwest corner of the main square of the modern village of Sacalaca. In this plaza lies a colonial church (to the east), the remains of a Prehispanic acropolis (to the northeast), and several modified houses whose origin seems to date back to the historical or colonial period. Prehispanic ruins and part of the plaza were topographically recorded in 2003 (Shaw et al. 2003:40-54).

The well curb is rectangular. In its center are two stone pillars, still plastered, where a wooden beam lies. This beam is used to support a pulley to draw water.

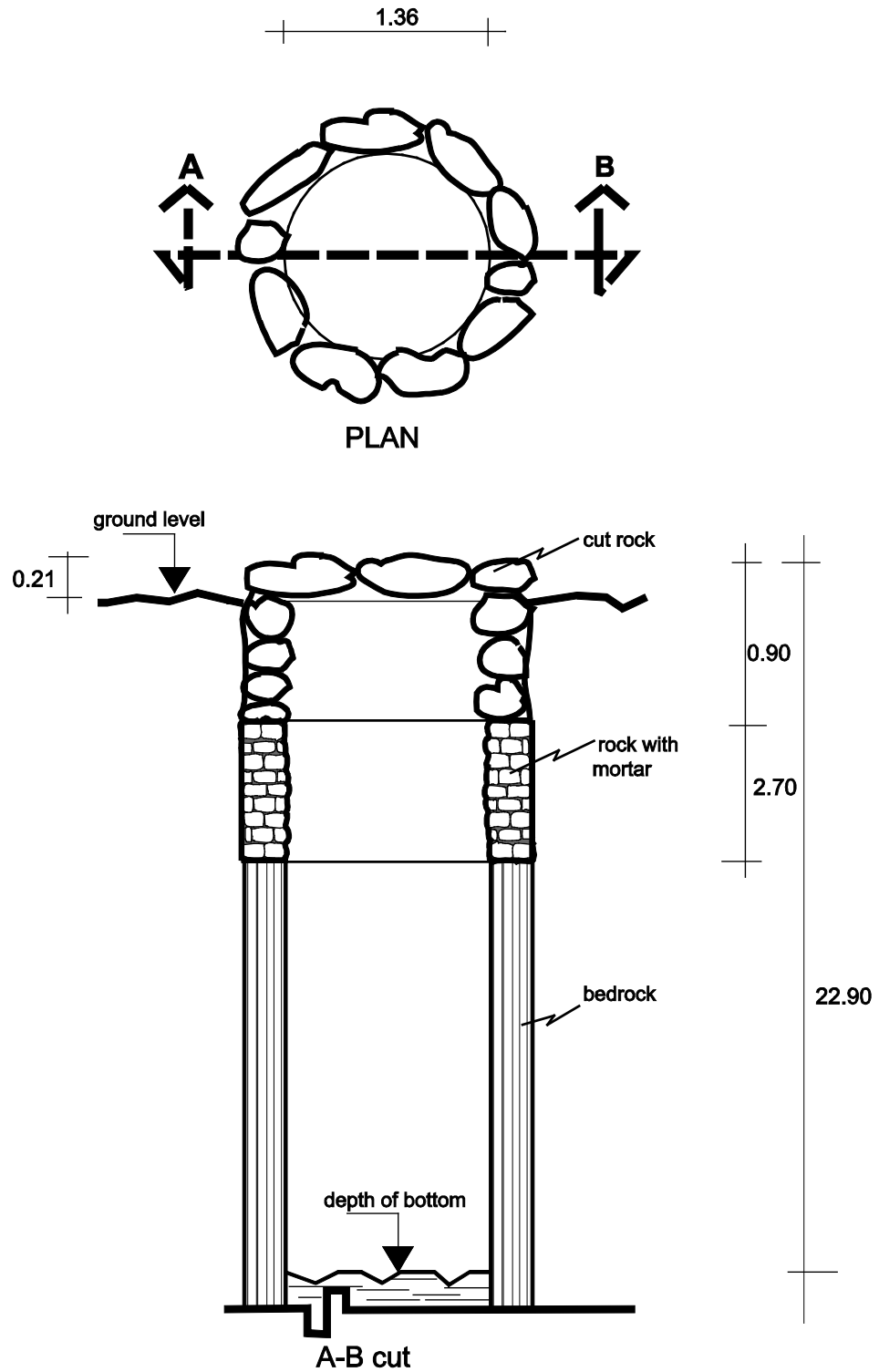

Figure 141. Sketch Map of the Well of Parcela Escolar

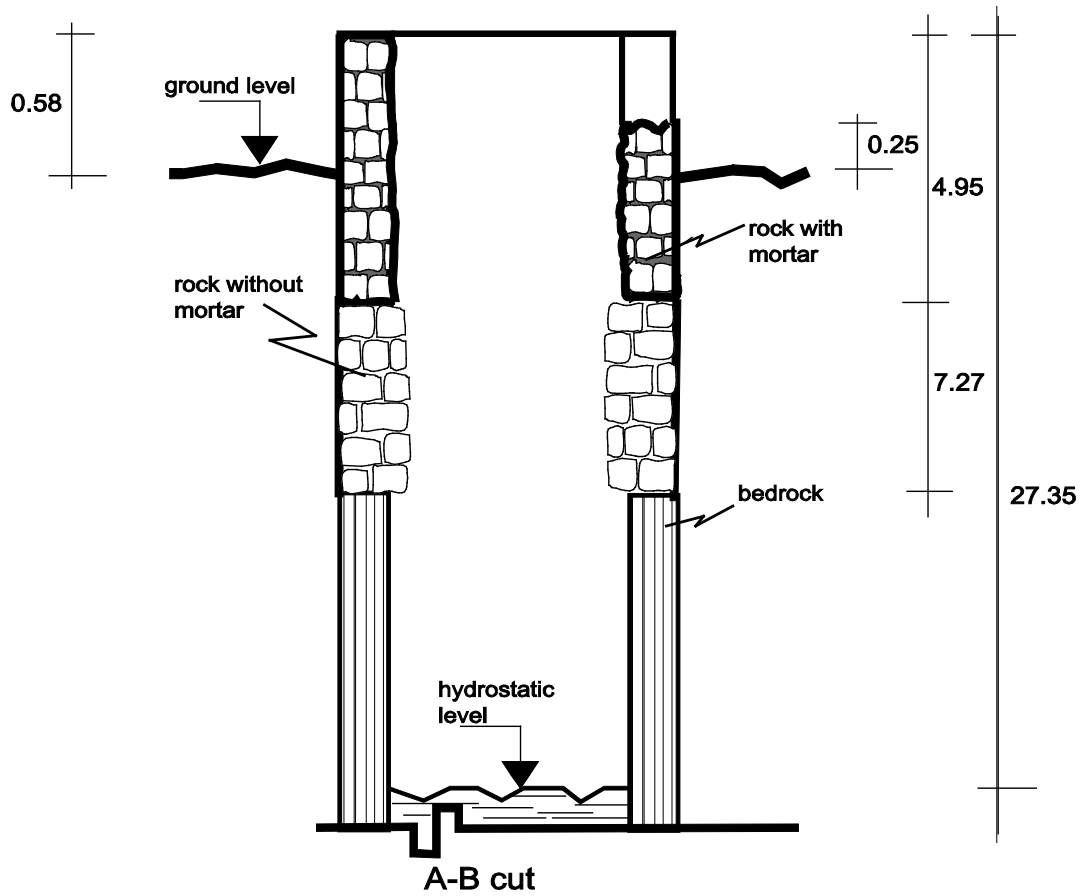
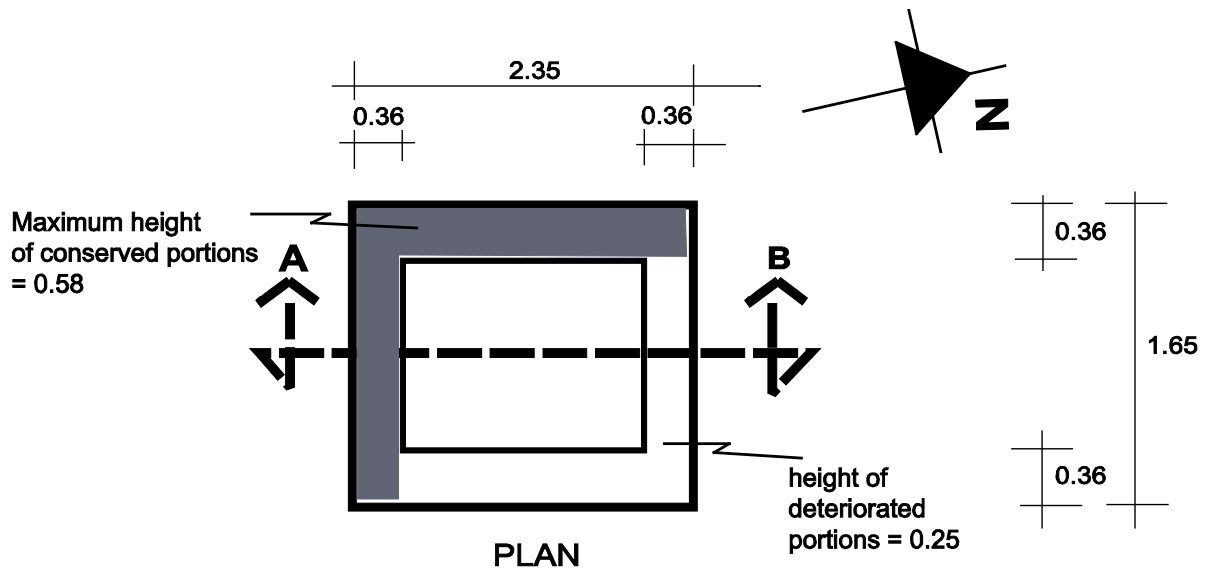

Figure 142. Sketch Map of the Well of Ramonal Poniente

The curb (of 2 x 1.8 m) is 80 cm height and has a thickness of about 40 cm. It has a coating on its exterior and interior walls, but the inside coating only reaches 30 cm deep. The interior plaster has a different texture and color than the outside.

The inner walls of the well included three sections; the first goes from the top of the curb to 90 cm in depth and is composed by rocks with mortar. The second is the rock covered with plaster, while the third is carved limestone, which reaches the bottom of the well.

Regarding possible construction and modification phases, we can state that this feature has at least four stages. The first was when the bedrock was carved out until the water table. The second stage was when the limestone was covered with stucco, while the third was when they built the curb and posts and covered the curb with plaster. The last phase must have happened when the well was reused by the contemporary inhabitants, when a new plaster surface and the wooden beam were installed.

Sacalaca, South Well

This well is located on the west side of the southern plaza of Sacalaca village. On the opposite side, the east, another historic church building is constructed. About two years ago, the area was transformed into a community park, as part of an eco-tourism project. The well was also slightly modified during these labors. Due to its central location, this well had seen several modifications through time.

The well is rectangular in shape. It also has a stone frame whose top is a triangle that seems to be a pediment. This triangle is topped by a cross that stands on the pediment's apex. Between the poles of the frame an embedded beam is also found. On this beam, the extraction pulley is positioned. The well sits on a platform covered by well cut stones. Today, the well is dry and full of debris. Its bottom is at a depth of 21.7 m.

As stated, the curb is rectangular (about 3.7 x 2.1 m) and is 60 cm tall. The thickness of its walls is close to the 40 cm. Its plastered surfaces have two colors, one white (stucco) and one gray (cement).

This well displayed two sections in the passage; from the level of the top of the curb to 6.5 m deep is rectangular, while from this point until the bottom it is circular. The walls are constructed in three sections. The first stage goes from the top of the curb to 1.3 m below and is composed of mortared stones. From this point to 5.2 m in depth, the stones are placed side-by-side without any other material or mortar. The circular passage of the well was directly carved into the bedrock.

Due its central position on the southern plaza, this feature has undergone several modifications. Stratigraphically, this feature may have had five construction phases. The first was when the passage of the well was carved into the bedrock. The second is when the shape was changed and a rectangular conduct of stones without mortar was built, which probably reached the base of the curb. A third stage must have occurred when the stones were placed with mortar, the curb was built, and the poles of the frame were erected. A fourth phase came when gray cement sections were added, perhaps along with the top of the triangle and the cross. Its last phase is the one that occurred a few years ago when the whole plaza was modified as part of an eco-tourism project. These modifications included a new cement surface and some cement additions.

Sahkabch'en

Sahkabch'en is located about 13 km southeast of the present village of Saban. About 400 m to the southeast of the well, a Prehispanic structure is located (Structure N1E1-1), which was recorded in 2008 (Flores and Shaw 2008:79-82). To the south of the well, a few meters ahead, a water trough is located. However, this feature was not inspected in detail, due to dense vegetation that surrounded it. The water table is at a depth of about 25 m.

The curb of the well is circular, around 2 m in diameter. It is 64 m tall and its walls are about 40 cm thick. The top and exterior walls of the curb are plastered and the coating is well preserved (Figure 143).

The internal structure of the well is clearly differentiated by two shapes and construction material. Initially, the shape is circular from the top of the curb until around 6 m in depth and it is built with mortared stones. A second phase (which corresponds to the first period of construction of the passage) is square and was dug directly on the bedrock. Due to this modification, the inner walls of the two parts of the passage (circular and square) are skewed by 8 cm.

This well may have been built in three or four phases. The first one must have occurred when the bedrock was carved away, giving the rectangular shape. A second phase was added until the top of the ground surface, constructed with mortared stones in order to create the curb. During the third phase, the plastered surface was added. The last phase occurred when the wooden frame, and probably the plastered surface, was added to the curb.

San Andres

The site of San Andres is located northwest of the town of Sacalaca, at a distance of roughly 2.5 km. This well is still in use by farmers who work in the area. Approximately 80 m northwest of the well, several Prehispanic platforms are found.

The well is circular and has a wooden beam that supports a pulley to draw water. The water table is at 23 m deep (Figure 144). The curb is also circular (1.8 m diameter), the walls are 60 cm tall, and about 40 cm thick. Some plastered sections still remain, although they are not well preserved, which makes us think that this plaster is not of recent manufacture.

The interior walls display two sections. The portion from the curb until 1.2 m in depth is built with stones placed with mortar, while from this point to the water table was carved directly into the bedrock.

According to these observations, it appears that this well has had four construction phases. The first one occurred when the passage was directly carved into bedrock until the water table was reached. A second was when the stones were placed with mortar; the third was probably built when the curb and its coating were added. The latest stage must have happened when the crossbar and the post were positioned, but this must have occurred in recent times.

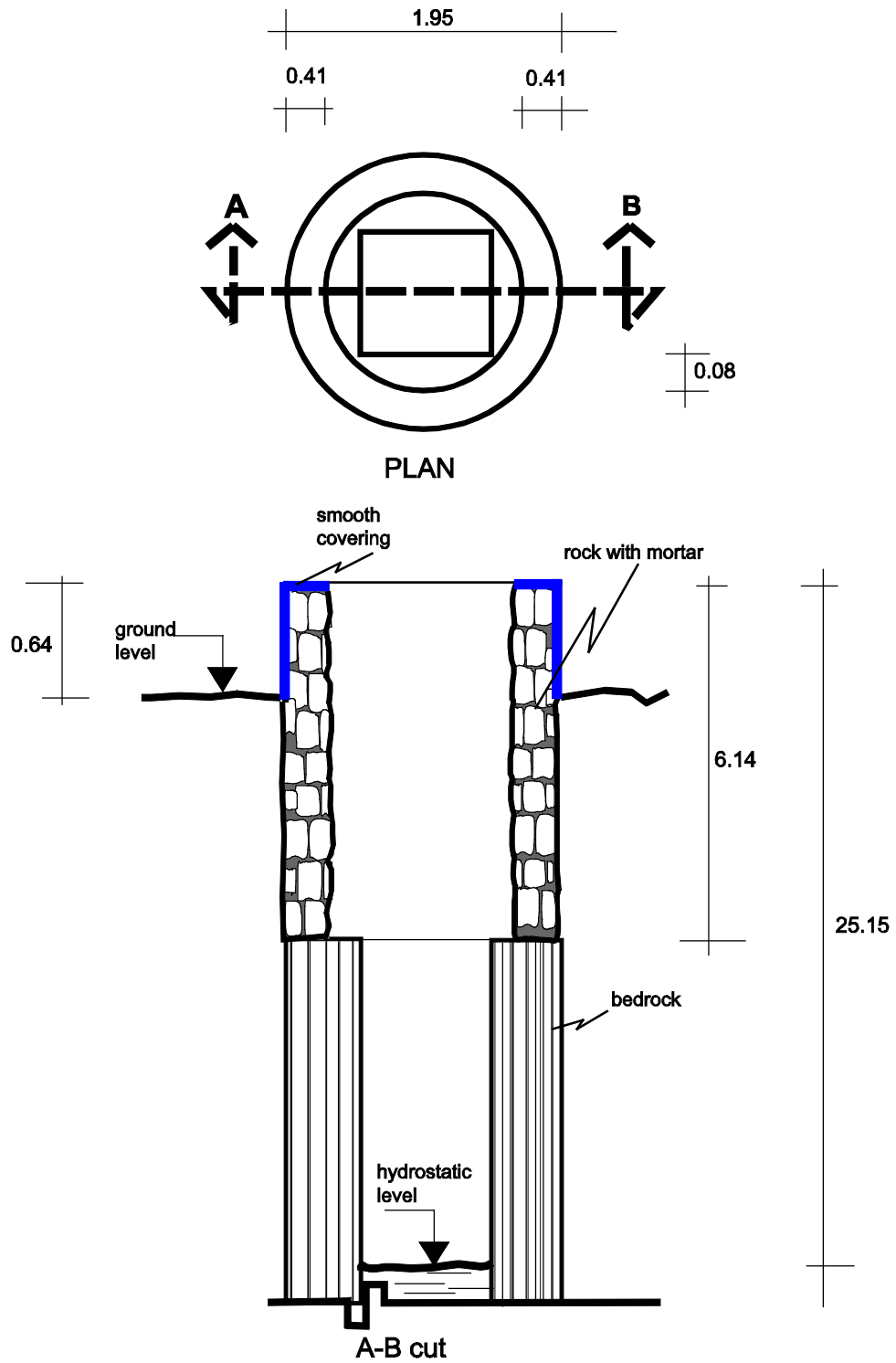

Figure 143. Sketch Map of the Well of Sahkabch'en

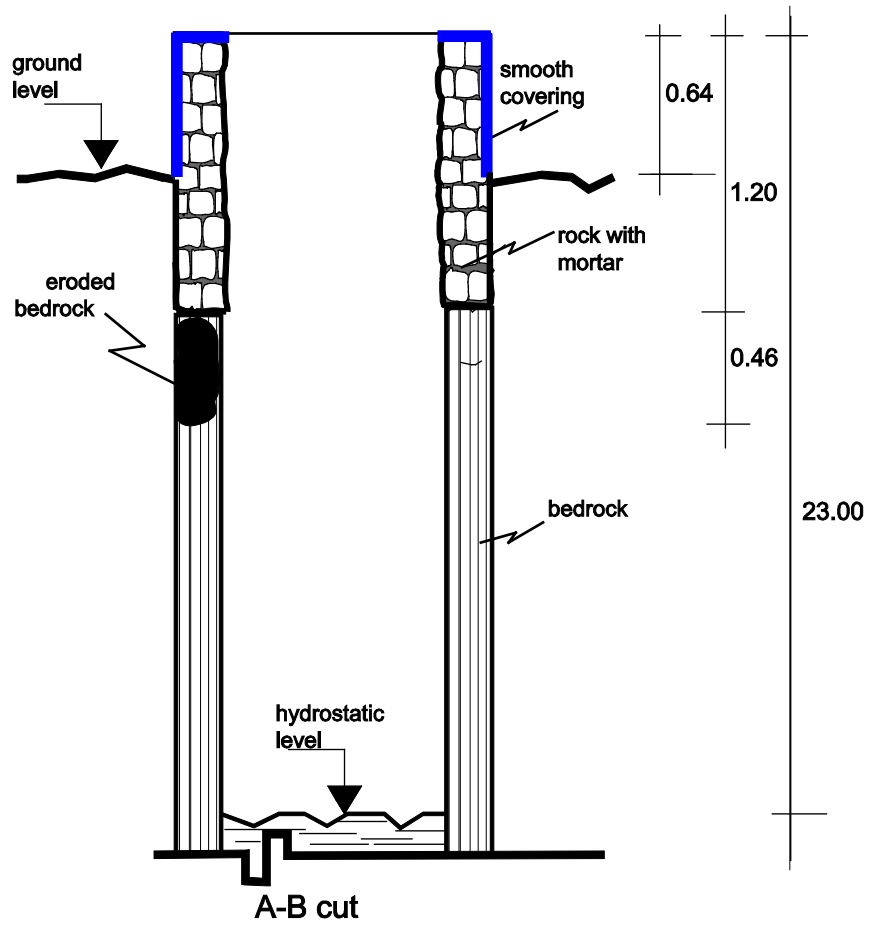
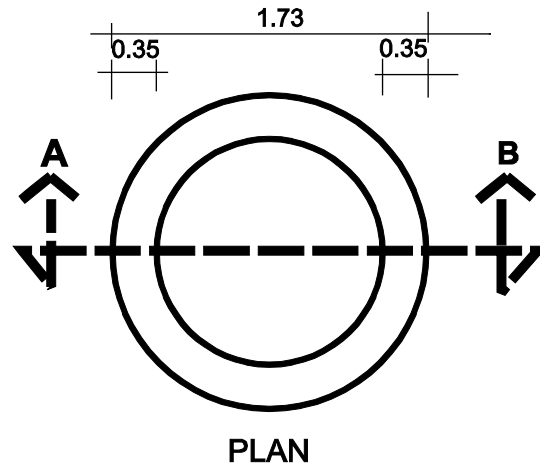

Figure 144. Sketch Map of the Well of San Andres

San Diego

The site of San Diego is located about 4.4 km southeast of the town of Sacalaca. Currently, the settlement is used by some farmers who work in the area. The site was topographically recorded this season (see Chapter 18 in this volume).

The well curb has a rectangular shape, and has a framework that supports a pulley to draw water. Water table is located at a depth of 25 m (Figure 145). The curb measures 1.8 x 1.4 m, and is half meter tall. Its wall is about 40 cm thick. It is built with stones joined with mortar, but without a plastered surface. The inner surface of the wall has two sections. The first phase goes from the surface of the curb to 1.5 m below and consists of stones with mortar. From this point to the water table, the passage was carved directly on the limestone.

According to the above mentioned, we can speculate that this well contains three constructive phases. First phase was when the bedrock was carved until the water table, while the second phase corresponds to when the stones with mortar were placed. The last phase was when the wooden frame was added.

San Isidro (Saban)

The old Rancho San Isidro is located 12.5 km southeast of the modern village of Saban. Currently, the site is dedicated to the agriculture and beekeeping labors. About 100 m northwest of the well, a Prehispanic platform is located. This construction was mapped during this field season (see Chapter 11 this volume). The water table is at a depth of 25 m (Figure 146).

The well curb is rectangular (about 2.3 x 2 m); it's about 40 cm tall and around 30 cm thick. The curb, compared to other wells observed in the region, is quite low. It is constructed with several carved stones (probably reused from some Prehispanic structure) without mortar, placed side by side. The feature is not well preserved. Its northeast and southeast corners are absent.

The walls of the passage have two different sections. Below the surface, and until 40 cm deep, the stones are placed with mortar. From this point until the water table, the well was directly carved into bedrock.

Considering the above mentioned data, probably the structure of this well has had several construction phases or modifications. First, the well was directly carved into bedrock, while the second was when the passage was coated with stones. The last stage occurred when the curb was added; it corresponds to the changes that have occurred in recent times, when the wooden posts and crossbar were installed to extract the water.

San Isidro (Sacalaca)

The site of San Isidro is located about 4 km southeast of the town of Sacalaca. The site was topographically recorded this season (see Chapter 19 this volume). Farming and beekeeping labors are currently carried out at the site.

The well curb is circular, and has a wooden frame that supports a pulley to draw water. The water table is at 25 m deep. East of this well, an electric pumping system to extract water has been added.

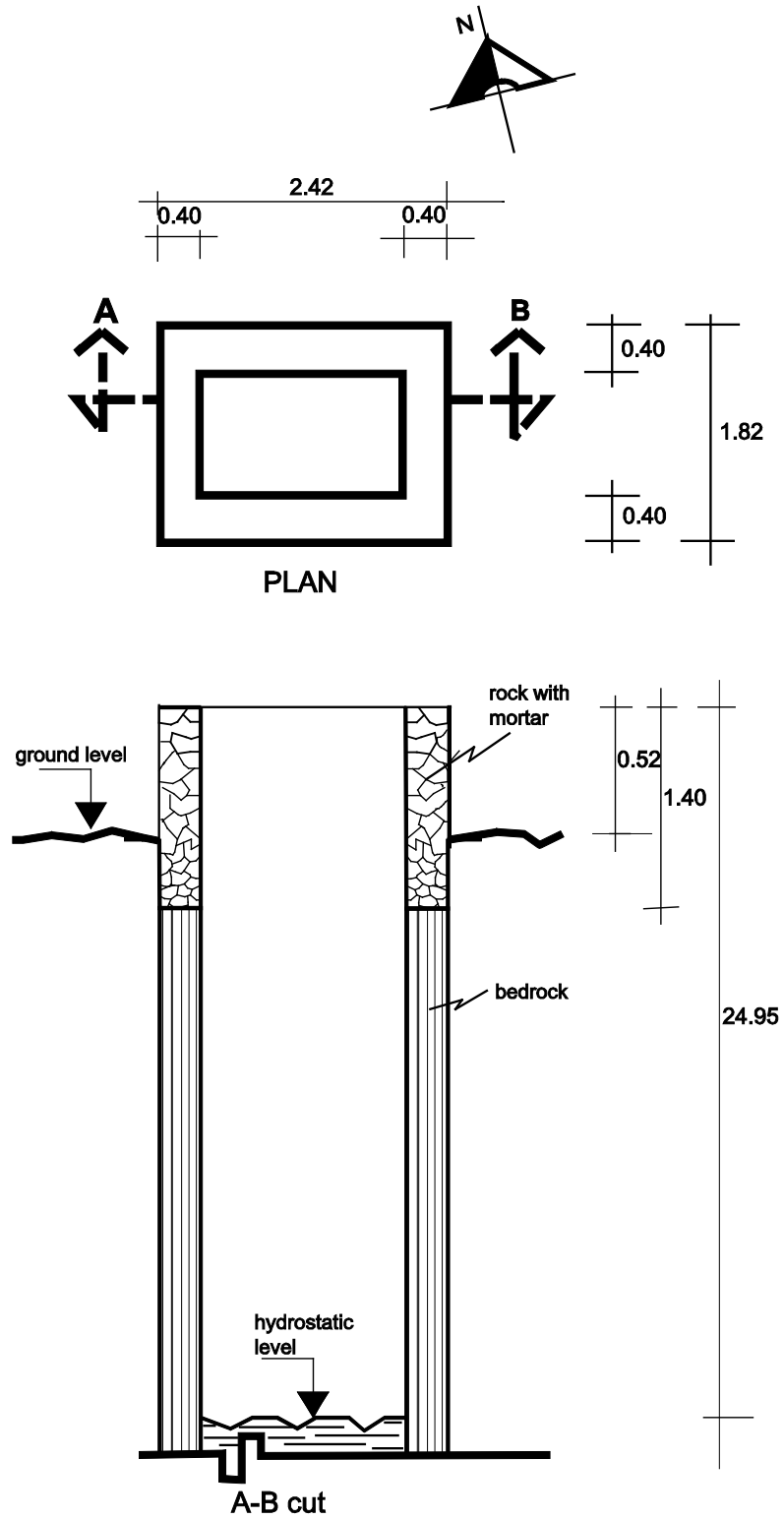

Figure 145. Sketch Map of the Well of San Diego

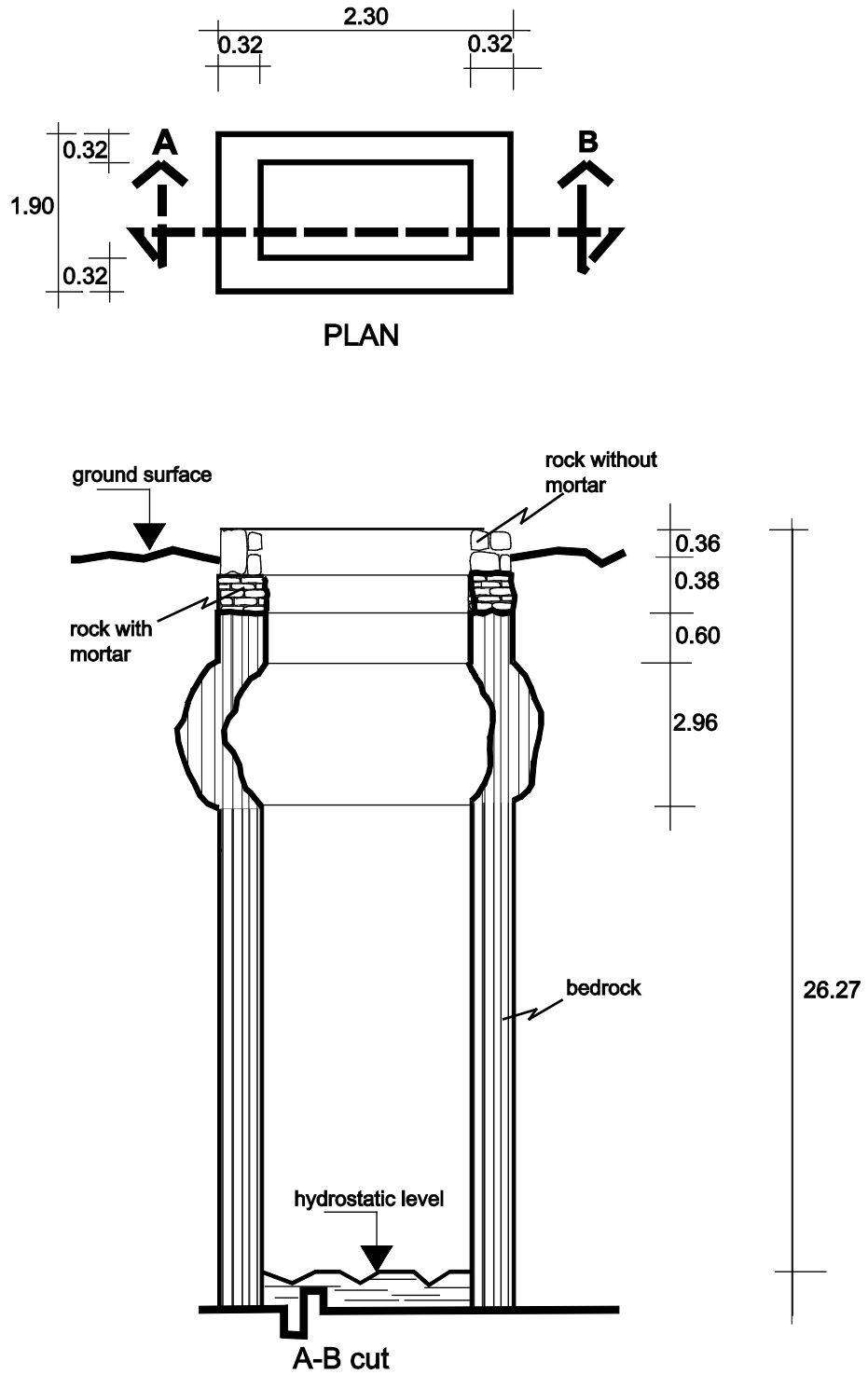

Figure 146. Sketch Map of the Well of San Isidro, Saban

The curb is 1.9 m in diameter; 70 cm tall, and 40 cm thick. The exterior plaster is of recent manufacture. The interior wall of the passage has three sections. The first extends from the top of the curb to 1.2 m deep, and consists of stones laid with mortar. The next 40 cm are rocks placed side-by-side that seem to lack of any mortar. After this point, the well was directly carved on the limestone until it reached the water table.

Considering this, we speculate that the well is the result of five phases. The first phase occurred when the passage was carved directly on the limestone. The second was when the stones with no mortar were placed. A third one happened when the stones with mortar were positioned with plaster; then, the curb was build (the fourth phase). A final stage came when the wooden frame was added, as well as the pumping system.

San Juan

The site of San Juan is located about 6 km northwest of the modern town of Sacalaca (see Chapter 20 this volume). The site is currently dedicated to farming and beekeeping. About 30 m southeast of the well, some Prehispanic platforms were located.

The curb of the well is circular. In two of its walls are two wooden posts and a crossbar. The water table is about 26 m deep (Figure 147). The curb of the well is 1.9 m in diameter, 72 cm in height and 35 cm thick. The inner wall of the well is divided into three sections. From the top of the curb until one meter in depth, the walls are covered by plaster. From this point until 2.2 m in depth, the walls are composed of stones with mortar. For the remainder of the passage until the bottom, the well was directly carved into the limestone.

As described above, this well had four construction phases. The first one occurred when the rock was directly carved from the original ground surface to the water table. The second phase was when the stones were placed with mortar. The third one is when the curb was built, while the last was when the perishable wooden structure was placed. During this phase, the plaster coating was also added to the curb; this seems to have occurred in recent times.

San Pablo

The site of San Pablo is located about 5 km southeast of the modern town of Sacalaca. Currently it is used by local farmers as a workstation.

The well is circular and has two wooden poles with a crossbar, which supports a pulley. At the top of the curb, a Prehispanic "*pila*" or *metate* (grinding stone) was added in recent times. The well is connected by a channel that was probably a drain over a low wall. The water table is at a depth of 30 m (Figure 148). The curb (of almost 2 m in diameter) is 60 cm high and 40 cm thick. The stucco coating is not well preserved.

The inner wall of the well is divided into two sections. From the curb of the well until around one meter in depth, the wall is made of stones placed with mortar. From this point to the water table, the passage was directly carved into the limestone.

According to the above mentioned description, it can be assumed that the well has five construction phases. The first one was when the bedrock was directly carved to the water table. The second phase was when the stones were settled with mortar, which probably reached the base of the curb. The third stage must have happened

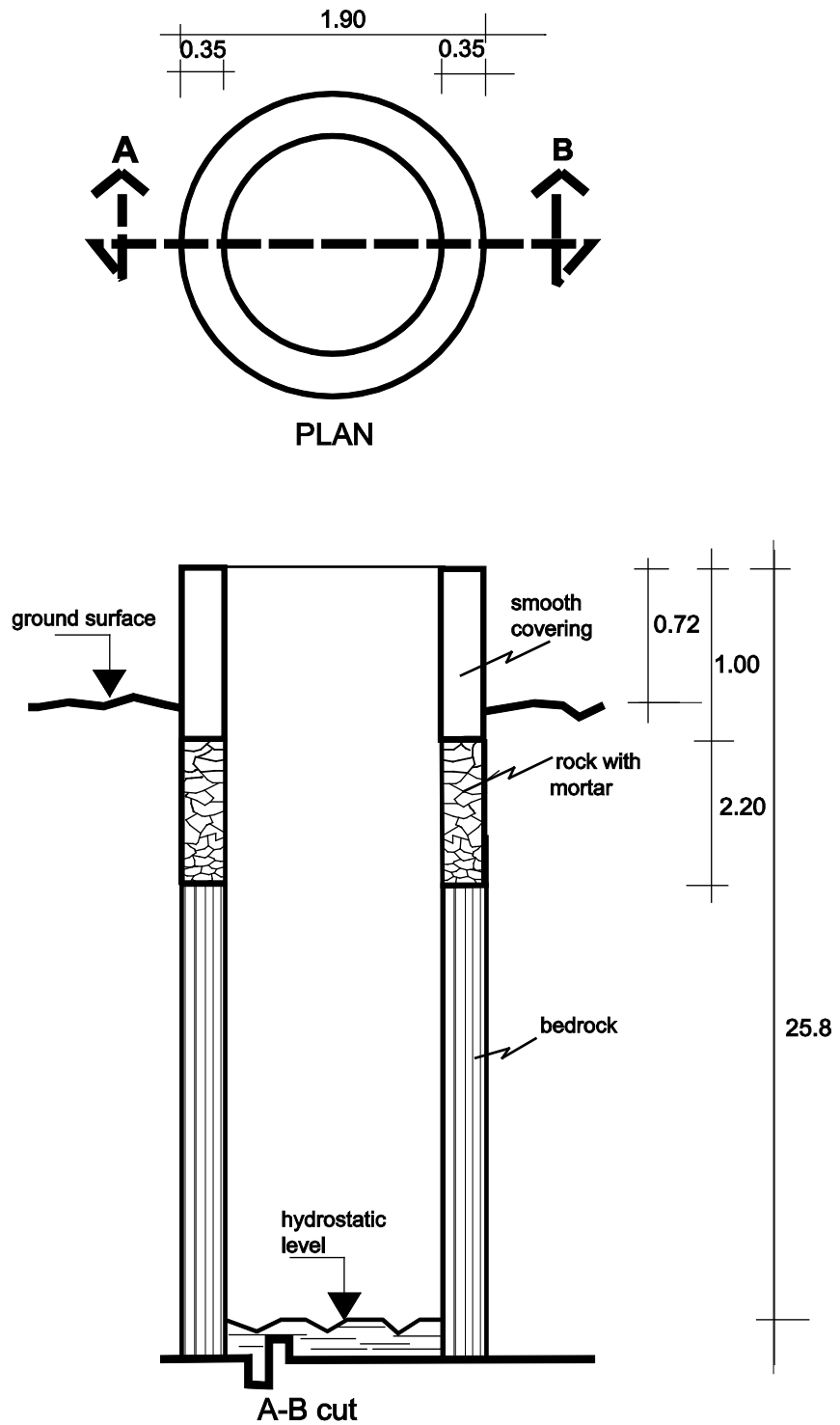

Figure 147. Sketch Map of the Well of San Juan

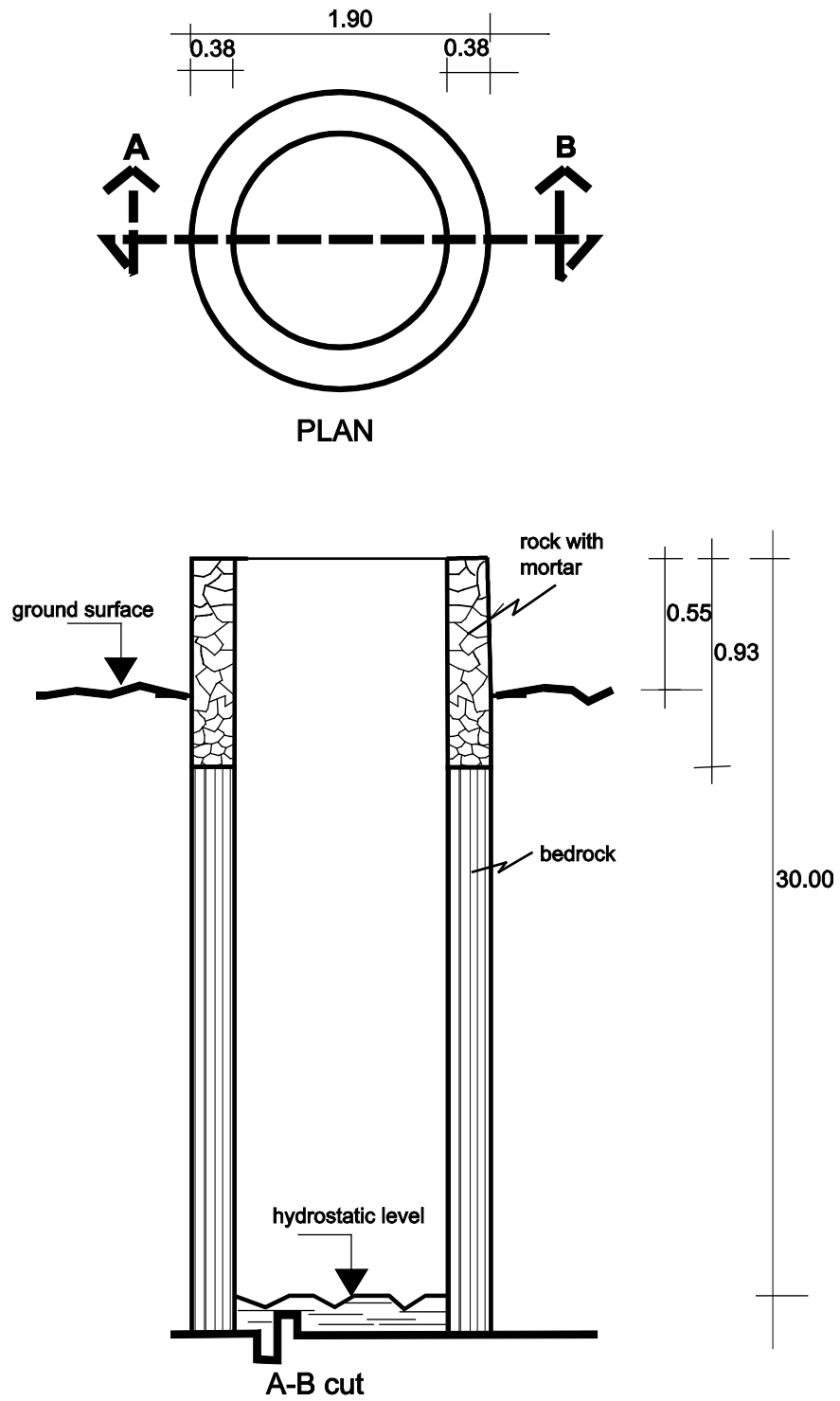

Figure 148. Sketch Map of the Well of San Pablo

when the curb and the small wall that served as a drain were built. The fourth phase was when the stucco coating was applied. Its final stage was when the wooden post was added, and a few stones and joints were replaced.

Santa Elena

Santa Elena is located around 5 km north of the modern town of Sacalaca. On this site lies a small village of about three families as permanent residents. As has been noted in Chapter 21, these contemporary constructions share the space with Prehispanic and historic ruins.

The well is located in the northern part of the settlement and has a quadrangular shape. The well has a wooden frame (one of the poles is in reality a tree), in which is placed a crossbar support for a pulley for water extraction. Prehispanic structures are located at 150 m southeast of the feature. The curb of the well is square (almost 2 m on a side), 80 cm in height, and about 40 cm thick. Its plaster surface is of recent manufacture.

The passage of the well is circular and is divided into three segments. From the curb's level until one meter in depth, it is covered with rocks placed with mortar (the stones are well cut and rectangular or square, probably taken and re-used from one of the older structures in the vicinity). The first meter corresponds to the square section of the well. After this point, until the 3.6 m in depth, the inner wall is circular and covered by rocks (also well cut) placed with mortar. From this point until the bottom, the well was directly carved into the limestone.

Based on the above mentioned information, we assume that the well has had four construction stages. The first one occurred when the rock was excavated until the bottom of the well. The second was when the rocks with mortar were placed. The third one occurred when the curb was built and the well cut stones were placed in various segments of the interior walls of the well's passage. One last step must have occurred when a series modifications were made for its current use; these included the cement coating of the curb, the wooden post, and the crossbar.

Yaxche 1

Yaxche 1 is located 9 km southeast of the modern village of Saban. This year this settlement was topographically recorded (see Chapter 14 this volume). To the east and southeast of the well, an old ranch's remains (sections of *albarradas* and pens) were found, while 150 m west is a cluster of Prehispanic structures.

Today, the well has been reused by farmers. The exterior walls of the curb have had recent modifications, in which a new coating was added. This new surface has the date of "Jueves 2-19-2009." The water table is at 36 m deep (Figure 149).

The curb is circular in shape and 1.8 m in diameter. Its height, including the surface, is around 60 cm tall. The wall thickness is about 30 cm. The interior wall has three sections. From the top of the curb until 50 cm deep, the stones are placed with a new mortar, while from 50 to 80 cm the rocks and mortar seems to be older. From this point until the water table, the well was dug directly into the bedrock.

Based on the above mentioned information, we speculate that this well has at least three construction stages. The first occurred when the passage was carved directly into the limestone, while the second was when the stones were placed with

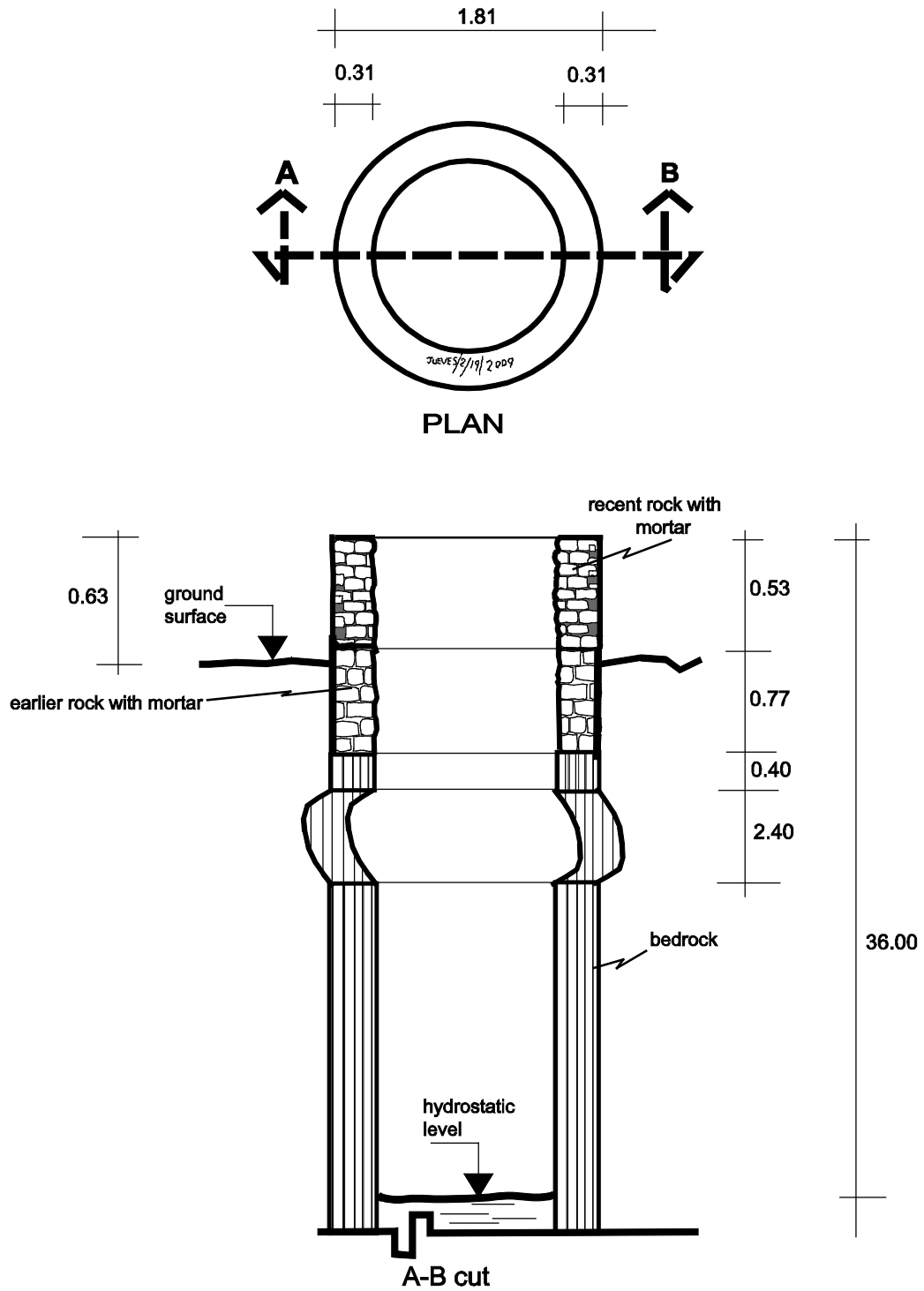

Figure 149. Sketch Map of the Well of Yaxche 1

binder, which must have reached the surface of the curb originally. The third stage occurred when the well was reused, the curb was repaired, and many stones were replaced. Furthermore, it was covered with a new cement surface, providing a new coating.

Yodzonot

Yodzonot is located around 2.5 km southwest of Sacalaca. At the site are the remains of a historic settlement, as well as several areas with Prehispanic ruins (see Chapter 25 this volume). The well is located in a depression, with respect to the surrounding terrain, a sort of *rejollada* (lowland area), and is placed above the roof of a *cenote* (sinkhole).

The well is rectangular in shape, although the curb is not complete (sections of its walls have collapsed) and it has two poles and a crosspiece that supports a pulley (Figure 150). The curb, which measures 2.6 x 1.7 m, is built directly on the roof of a *cenote*. It has a height of 50 cm and a thickness of 40 cm. The curb was built with stones held with mortar. The inner wall of the well is divided into three segments. The first goes from the curb to a meter deep; it is composed of rocks with mortar. From this point until around 2 m deep, the walls seem to have a plastered surface that covers them entirely. The rest of the way is carved bedrock until the *cenote's* roof.

According to the above described information, it appears that this well has four construction phases. In the first phase, perhaps there existed an opening that led to the *cenote's* roof; the bedrock was carved and enlarged to create the rectangular opening. A second stage occurred when the stones were placed with mortar. The last phase could have happened when the curb was built. Furthermore, there were the additions of the wooden post and crossbar. The most recent modification took place in 2009, when the curb was coated with cement.

Final Comment

According to the data observed in majority of the wells at these sites, we can infer that are the result of several construction phases, whose temporality remains to be determined. Although they share similar forms and design, a more in-depth study of the techniques that were used to build them is still needed. Besides this, the most important question that the Project has about this features, the question of when they were built, still remains unresolved. It is necessary to develop test implications to determine if these features were constructed and used prehispanically and/ or whether they pre-date the Caste War (1847), when the region had an economic "boom." In any case, these hypotheses and questions could be tested in future seasons. This study, by no means exhaustive and conclusive, is the first step into the process of knowing how the ancient inhabitants of the region, the Prehispanic Maya, as well as Colonial and historic Maya and Ladinos resolved their need for water access in this harsh environment of the former Coahuah Province.

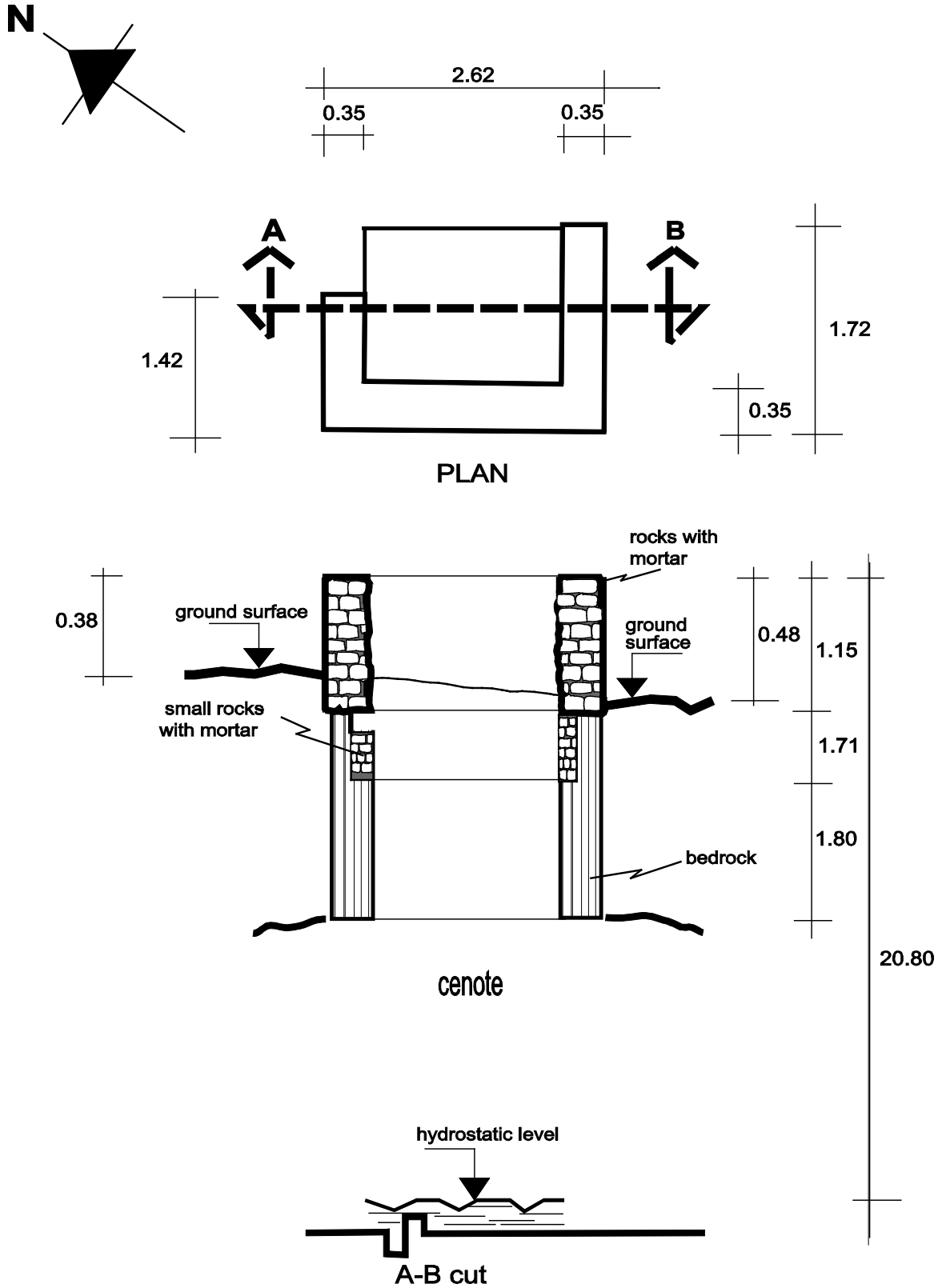

Figure 150. Sketch Map of the Well of Yodzonot

Part 5: Summary and Analysis

Chapter 48: Ceramic Summary from the 2010 Season of the Cochuah Regional Archaeological Survey

Dave Johnstone

Sampling within a region is an attempt to balance the need for data from many sites against the need for larger samples from specific sites. In order to gather a representative sample from a given site, it is necessary to excavate multiple test pits from a variety of contexts. Such excavations can consume a great deal of the season, and limit the number of sites that can be tested. This year, the majority of our excavations were concentrated in the southern portion of the research area which had thus far been under-sampled in relation to the north. Small opportunistic surface collections were also made from additional sites to complement data available from architecture and extend or refine our chronology for those sites. The sherds were analyzed using Type-Variety (Smith et al. 1960). A total of 10,591 sherds from eight sites were analyzed this season (Tables 2-14), making it the second largest sample collected by the CRAS project to date. Additionally, 67 surface collected sherds from 7 sites were also analyzed.

Parcela Escolar

This season's two operations produced a smaller ceramic sample than that from 2005, and yielded a lower frequency sherds identified to type. This was due in large part to the difference in contexts. The well drained platform fill of Operation 1 meant that the sherds were in a better state of preservation than those from either Operation 2 or Operation 3. Despite the poor preservation, it was possible to isolate two complexes (Table 4), dating to the Late Formative and Terminal Classic Periods. To date, all of the early ceramics from the site have come from tertiary context, admixed with the Terminal Classic material.

San Felipe

The four operations that were excavated at San Felipe produced a large ceramic sample. This season, it was possible to identify and describe Late Formative, Early Classic and Terminal Classic complexes; each associate with at least one construction episode. Notable in its absence is the Late Classic, represented by a mere nine sherds.

A large sample of Middle Formative sherds admixed into later deposits. When combined with the sample from 2005, it allowed for the naming of a complex associated with that period. The Middle Formative Xux component is dominated by locally produced types from the Chuhintá and Dzudzuquil ceramic groups. Types from the Joventud and Muxanal groups also appear, though in low frequency, and are likely traded into the region from the Petén.

Table 1. Ceramic Complexes within the Coahuah Region

Period	Ichmul	Nohcacab	Parcela Escolar	San Felipe	San Lorenzo	Sisal	Yo'okop
Postclassic							Kahuil
Terminal Classic	San Juan	Ma'ax	Kuts	Chiwoh	Chimes	Sabim	Balam Kin
Late Classic		Keh					Chac
Early Classic	San Pedro	Ch'omak		Pech	Hub	T'ul	Ixchel
Late Formative	San Andres	Kitam	Ulum	K'oxol	Nok	Wech	Pahuatun
Middle Formative		Chi'ik		Xux	Sinik		Izamna

San Lorenzo

San Lorenzo displays the same four periods of occupation as San Felipe. The four ceramic components: Sinik, Nok, Hub, and Chimes correspond to the Middle Formative, Late Formative, Early Classic, and Terminal Classic periods. While the sherds dating to the Middle Formative derive from tertiary context mixed with other periods, all other complexes are associated with corresponding construction episodes. Like San Felipe, sherds dating to the Late Classic are virtually absent, with only 18 sherds recovered mixed with Terminal Classic lots.

Sisal

Sisal's seven operations yielded a ceramic sample smaller only than those sites within the CRAS study area which had been subject to areal excavation (Yo'okop and Nohcacab). Despite the large sample though, only three complexes have been identified at Sisal: the Wech, T'ul, and Sabim. These correspond to the Late Formative, Early Classic, and Terminal Classic periods. While construction episodes are associated with the latter phases, sherds dating from the Late Formative are incorporated into later construction. Like the aforementioned sites, there is a paucity of sherds dating to the Late Classic at Sisal.

Ramonal Quemado

Despite three operations at Ramonal Quemado, the ceramic sample was disappointing in two regards: its size, and its quality. Over half of the 140 sherds recovered from this site were unidentified. The poor preservation was partly a function of repeated burning of the site, and in part by the poor drainage. As a result it was not possible to name a ceramic complex for Ramonal Quemado. The sherds were nearly evenly split between those from the Late Formative, and those from the Terminal Classic.

Hopemul

While the single operation at Hopemul yielded a larger ceramic sample than that of Ramonal Quemado, the quality of its preservation was even poorer, with two-thirds of the sherds being unidentified. The reasons for this poor preservation were the same as at the previous site: burning and poor drainage. As the identified ceramics were few, named ceramic complexes for this site were withheld pending a larger, more representative sample. As with Ramonal Quemado, the identified sherds were split between types from the Late Formative and Terminal Classic, as well as the inclusion of some Middle Formative types.

Gruta de Alux

Gruta de Alux was selected for excavation in order to test the hypothesis that the circular foundation braces may have been an architectural signature of the Postclassic period. If this hypothesis were true, we would expect to see Postclassic ceramics associated with these structures. This did not however prove to be the case. The ceramic preservation at Gruta de Alux was extremely poor, mostly due to exposure to repeated *milpa* fires. While a few Postclassic sherds were recovered, the majority of the ceramics dated to the Terminal Classic period.

Sahcabchen

The ceramic sample from Sacabchen was relatively large, but in a very poor state of preservation owing to the poorly drained soil from which they were excavated. As a result, 70% of the sample was unidentified. All but one of the lots dated to the Terminal Classic, with the sherds divided between that period and the Late Formative period. In neither case was the sample big enough to warrant naming a ceramic component.

Surface Collections

Surface collections were made from Ramonal Oriente, Santa Cruz, Xbalcheil, Xtojil, Yodzonot, La Esperanza, and Palomar. The samples from Ramonal Oriente Santa Cruz, Xtojil and Yodzonot dated to the Terminal Classic. In addition to Terminal Classic types, the samples from Xbalcheil and Palomar included both Late Formative and Early Classic types. Those from La Esperanza proved to be the most interesting, containing types spanning the Early Classic through the Postclassic. Of particular interest were the sherds from the Late Classic; a period seldom represented in other sites within the study area. As such, this site deserves more attention in future seasons.

Conclusions

The large ceramic sample recovered during the 2010 season permits a more thorough understanding not only of the individual sites tested, but of the region as a whole. This is despite the poor ceramic preservation at several localities.

Nearly half of the sites excavated within the CRAS study area have yielded some sherds dating to the Middle Formative period. To date however, no primary deposits containing pure Middle Formative ceramics have been encountered. All Middle Formative ceramics were recovered from construction fill associated with later occupation. Given this, it is not surprising that the sites with the largest samples from

this time are those with the greatest number of excavation units. The large samples from San Felipe and San Lorenzo are comparable to those from Nohcacab and Yo'okop (Johnstone 2005), and cannot be included within the Mamom ceramic sphere. The infrequent presence of types common to that sphere however suggests that the Northern Yucatan was not isolated from the Petén region (Figure 151).

The Late Formative was represented ceramically at many of this season's sites, but only two of these, San Felipe and San Lorenzo, had associated construction. For those sites with ceramic components dating to this period, but no contemporaneous construction, the portions of those sites containing these deposits remain to be isolated. The ceramic complexes from all sites dating to this time period can be included in the Chicanel sphere, with a preponderance of types belonging to the Sierra Group (Figure 152). Of interest were a number of sherds of Lagartos Punctate, a type described at Uaxactun (Smith and Gifford 1966) with a coastal distribution (Simmons 1974, Ball 1978).

Early Classic ceramic complexes with associated construction were encountered at San Felipe, San Lorenzo and Sisal. The preponderance of types from the Yaxcaba and Xanaba groups place all of the named complexes within the Xculul ceramic sphere. Imported polychromes and glossy black ware from the Peten are recovered fairly frequently (Figure 153). This frequency does not seem to vary between sites in the northern portion of the study area, and those of the south, nor between large sites and small ones.

One of the biggest mysteries within the CRAS region is what happened during the Late Classic? Not one site tested this year had a sample that was large enough for a named ceramic complex. Those sites that hint at a possible occupation, such as Sisal, have extremely small samples admixed with later construction (Figure 154). Since we have tested 1/3 of the sites in the study area, this absence is probably not a sampling error. As it effect the whole region, itany explanation for the missing or reduced Late Classic will have to be systemic rather than culture-historic in nature. Clearly this time period demands further investigation in future seasons.

The Terminal Classic is the most well represented time period in our ceramic sample. In part, this is a function of being late in the sequence, and therefore close to the surface. Some sites such as Xbalcheil did not have their excavations carried to sterile due to time constraints, and might have missed earlier deposits. However, of the twenty sites we have sampled, not a single one has been free of ceramics dating to this time. In fact, it is the opposite of what we see during the Late Classic, with apparently every site in the region showing some evidence of occupation. The complexes are fairly similar in most respects, with some difference in the frequency of Thin Slate Ware (Figure 155). Despite these minor differences, all sites for which we have named ceramic complexes can be included in the western Cehpech ceramic sphere based on the high frequencies of types from the Muna and Chum groups.

Like the Late Classic, the ceramics from the Postclassic remains something of a mystery, despite Gruta de Alux being chosen specifically to target a possible Postclassic occupation. The site closest to having a sample large enough for a named complex, Sisal, has an extremely limited number of types, heavily dominated by Chen Mul incense burner fragments. The context for these (surface, and near shrines) result in an extremely biased sample favoring a specialized ritual sub-complex. As such, it is

difficult to directly compare the CRAS Postclassic ceramics with those from more intensely excavated sites such as Mayapan, or Tulum. The presence of Mama instead of Payil Redware hints at inclusion in the Tases ceramic sphere.

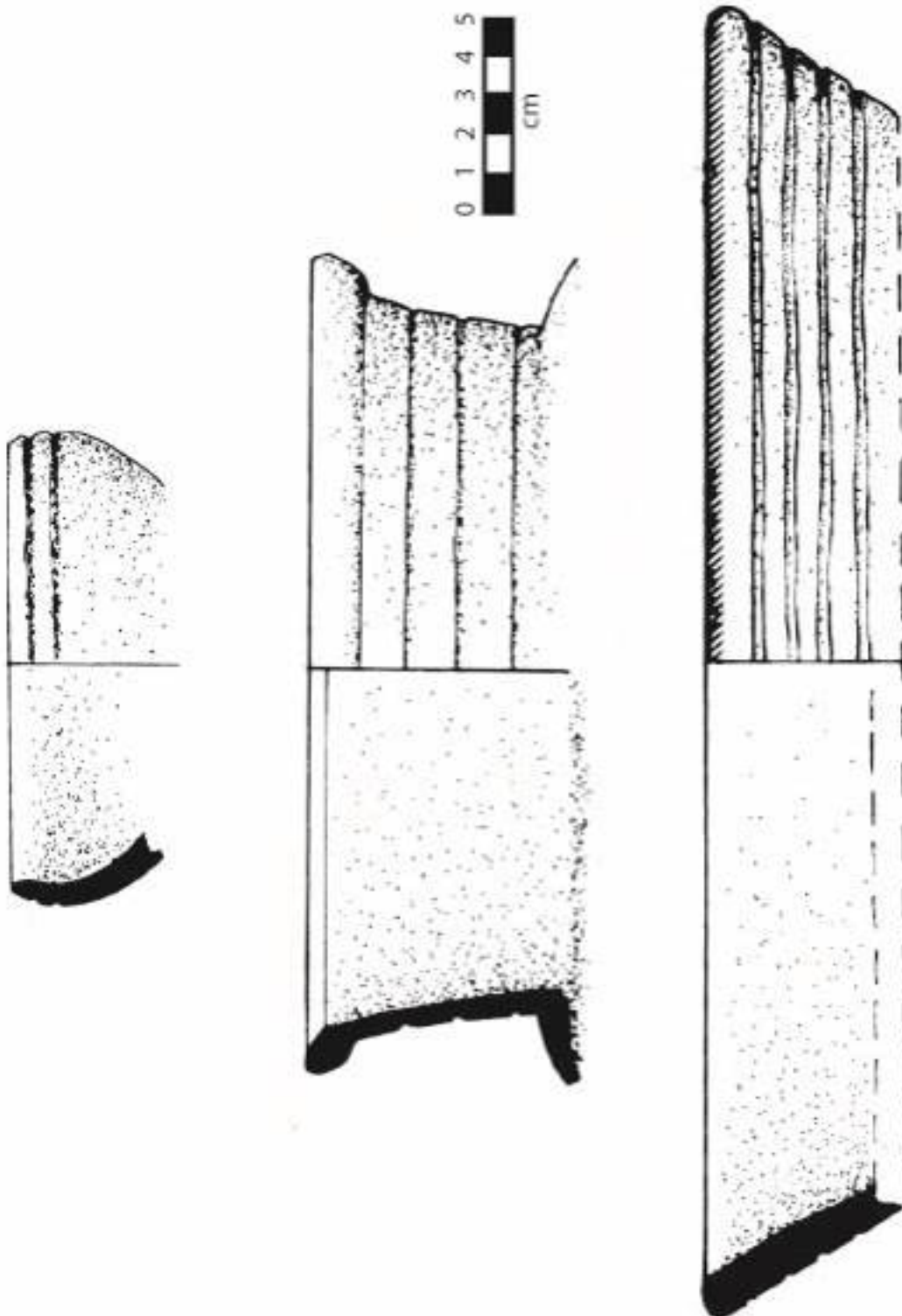

Figure 151. Middle Formative Ceramics: Tumben Incised (left and middle) and Uchben Incised Dichrome (right)

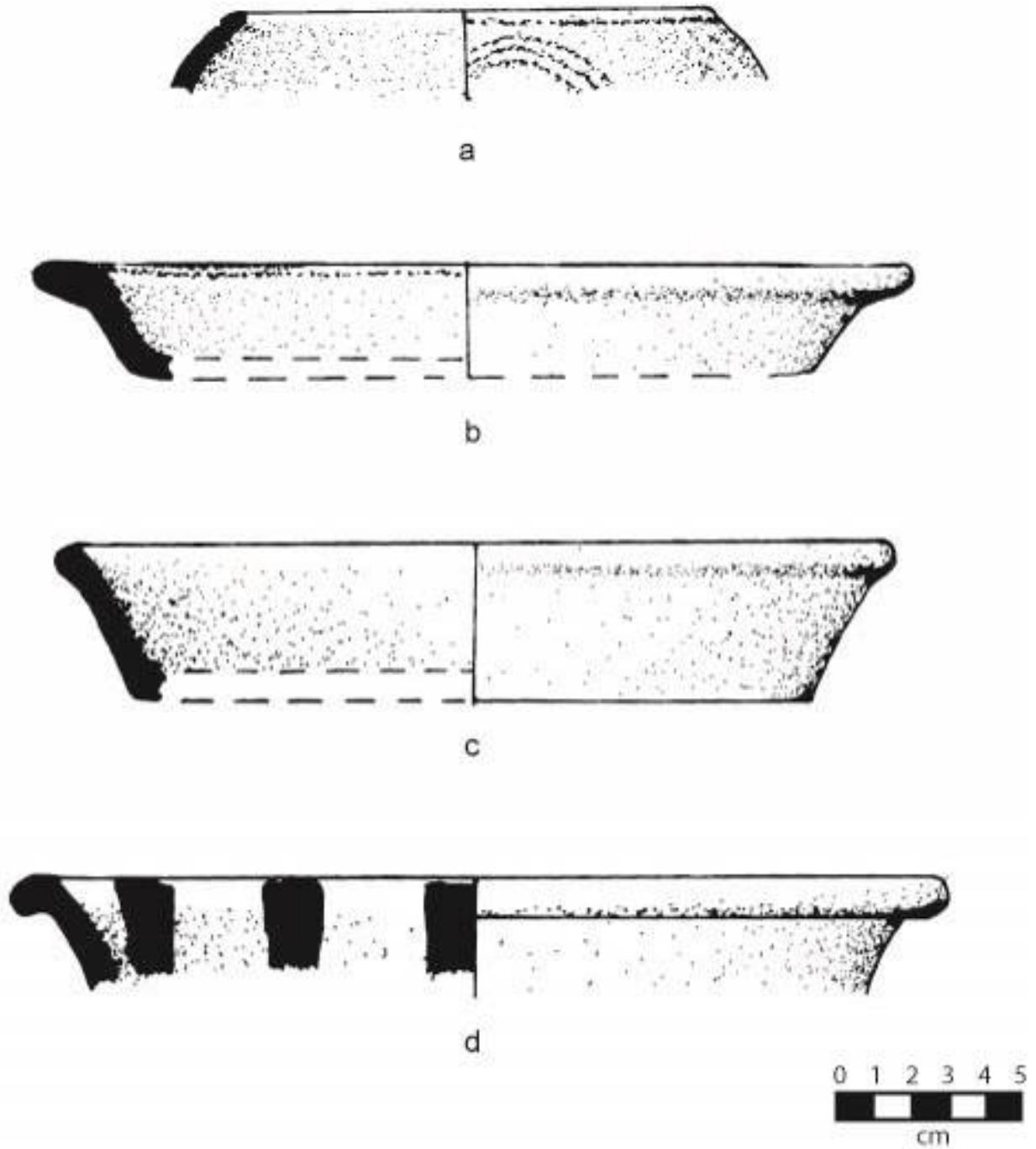

Figure 152. Late Formative Ceramics: Laguna Verde Incised (a and b), Sierra Red (c), and Repasto Black on Red (d)

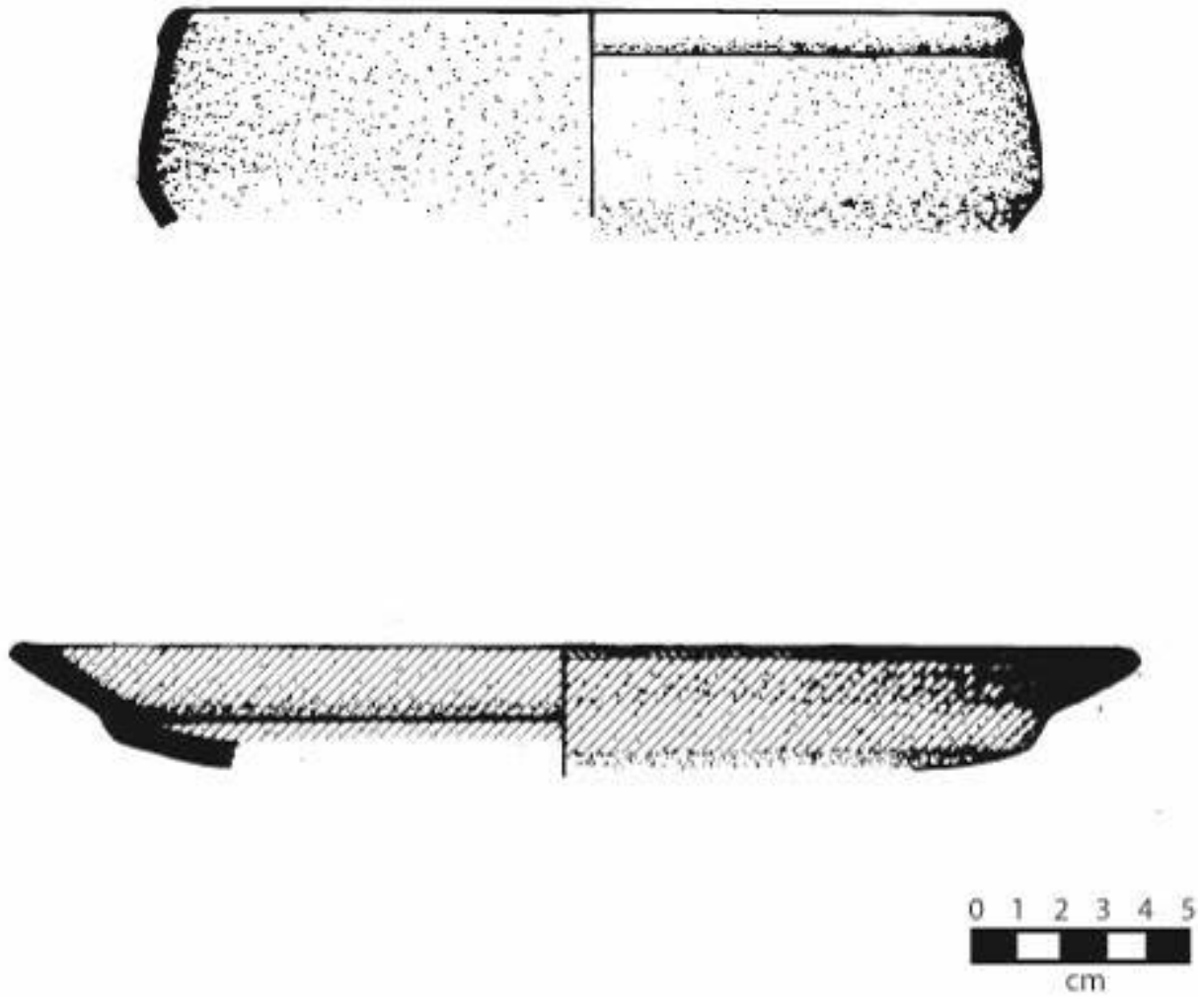

Figure 153. Early Classic Ceramics: Xanaba Red (top) and Dos Arroyos Orange Polychrome (bottom)

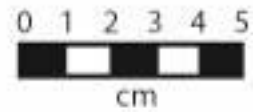
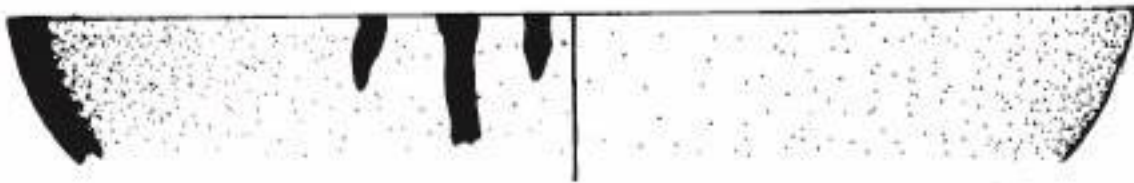

Figure 154. Late Classic Ceramics: Arena Red (top) and Sacalum Black on Slate (bottom)

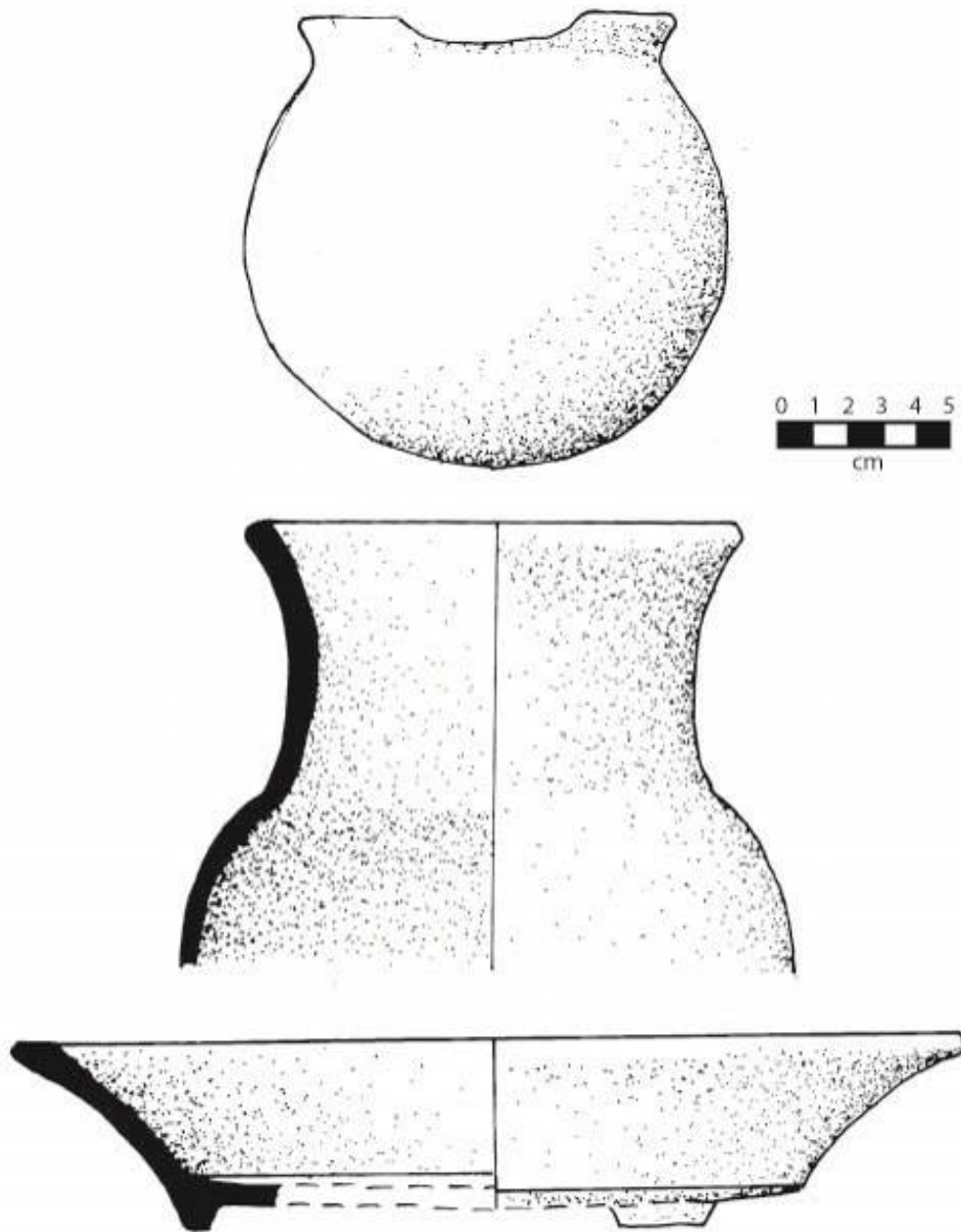

Figure 155. Terminal Classic Ceramics: Chum Unslipped (top) and Muna Slate (middle and bottom)

Table 2. Ceramics of Gruta de Alux

<u>Type</u>	1/1/1 (Op/Lev/Lot)	1/3/1	2/1/1	2/2/1	Total
Achiotes Unslipped					0
Chunhinta Black v. Ucu					0
Nacolal Incised					0
Dzocobel Red on Black					0
Joventud Red					0
Desvario Chamfered					0
Guitarra Incised					0
Dzudzuquil Cream to Buff					0
Tumben Incised					0
Majan Red on Cream					0
Tipikal Red on Striated					0
Unto Preslipped Striated Black					0
Chancenote Unslipped					0
Tancah Unslipped					0
Xanaba Red (LF)					0
Dzalpach Composite					0
Sierra Red			1		1
Laguna Verde Incised					0
Ciego Composite					0
Lagartos Punctate					0
Alta Mira Fluted					0
Repasto Black on Red					0
Flor Cream					0
Mateo Red on Cream					0
Polvero Black					0
Saban Unslipped					0
Yaxcaba Striated					0
Xanaba Red					0
Caucel Trickel on Red					0
Tituc Orange Polychrome v. Tituc					0
Huachinango Bichrome Incised					0
Balanza Black					0
Lucha Incised					0
Aguila Orange					0
Dos Arroyos Orange Polychrome					0
Caldero Buff Polychrome					0
Cetelac Fiber Tempered					0
Elote Impressed					0
Yalchak Striated					0
Maxcanu Buff					0

Table 2. Ceramics from Gruta de Alux

<u>Type</u>	1/1/1 (Op / Lev / Lot)	1/3/1	2/1/1	2/2/1	Total
Hunabchen Red					0
Kanachen Black					0
Tituc Orange Polychrome v. Tituc					0
Tituc Orange Polychrome v. Bandas					0
Dos Caras Striated					0
Sacalaca Striated					0
Encanto Striated v. Sacna					0
Arena Red		1			1
Batres Red					0
Lakin Impressed					0
Muna Slate (LC)					0
Sacalum Black on Slate (LC)					0
Saxche Orange Polychrome					0
Juleki Cream Polychrome					0
Chantori Black on Orange					0
Sayan Red on Cream					0
Chum Unslipped					0
Yokat Striated	5	11	4		20
Oxkutzcab Applique					0
Muna Slate	1	2			3
Sacalum Black on Slate					0
Tekit Incised					0
Tekit Incised v. Dzib					0
Akil Impressed					0
Teabo Red	1	2			3
Becal Incised					0
Ticul Thin Slate		1	1		2
Tabi Gouged-Incised					0
Dzitas Slate					0
Balantun Black on Slate					0
Chacmay Incised					0
Piste Striated					0
Tohil Group					0
Navula Unslipped			3		3
Yacman Striated					0
Chen Mul Modeled					0
Mama Red					0
Unidentified	21	65	20	1	107
Total sherds	28	83	28	1	140

Table 3. Ceramics from Hopemul

<u>Type</u>	1/1/1 (Op/Lev/Lot)	1/2/1	Total
Achiotes Unslipped			0
Chunhinta Black v. Ucu	2	6	8
Nacolal Incised		2	2
Dzocobel Red on Black			0
Joventud Red			0
Desvario Chamfered			0
Guitarra Incised			0
Dzudzuquil Cream to Buff		10	10
Tumben Incised		4	4
Majan Red on Cream			0
Tipikal Red on Striated			0
Unto Preslipped Striated Black			0
Chancenote Unslipped	2	2	4
Tancah Unslipped			0
Xanaba Red (LF)			0
Dzalpach Composite			0
Sierra Red	18	31	49
Laguna Verde Incised	1	7	8
Ciego Composite			0
Lagartos Punctate			0
Alta Mira Fluted			0
Repasto Black on Red			0
Flor Cream			0
Mateo Red on Cream			0
Polvero Black			0
Saban Unslipped			0
Yaxcaba Striated			0
Xanaba Red	2		2
Caucel Trickle on Red			0
Tituc Orange Polychrome v. Tituc			0
Huachinango Bichrome Incised			0
Balanza Black			0
Lucha Incised			0
Aguila Orange			0
Dos Arroyos Orange Polychrome			0
Caldero Buff Polychrome			0
Cetelac Fiber Tempered			0
Elote Impressed			0
Yalchak Striated			0
Maxcanu Buff			0

Table 3. Ceramics from Hopemul

<u>Type</u>	1/1/1 (Op / Lev / Lot)	1/2/1	Total
Hunabchen Red			0
Kanachen Black			0
Tituc Orange Polychrome v. Tituc			0
Tituc Orange Polychrome v. Bandas			0
Dos Caras Striated			0
Sacalaca Striated			0
Encanto Striated v. Sacna			0
Arena Red			0
Batres Red			0
Lakin Impressed			0
Muna Slate (LC)			0
Sacalum Black on Slate (LC)			0
Saxche Orange Polychrome			0
Juleki Cream Polychrome			0
Chantori Black on Orange			0
Sayan Red on Cream			0
Chum Unslipped			0
Yokat Striated	33		33
Oxkutzcab Applique			0
Muna Slate	7		7
Sacalum Black on Slate			0
Tekit Incised			0
Tekit Incised v. Dzib			0
Akil Impressed			0
Teabo Red	2		2
Becal Incised			0
Ticul Thin Slate			0
Tabi Gouged-Incised			0
Dzitas Slate			0
Balantun Black on Slate			0
Chacmay Incised			0
Piste Striated			0
Tohil Group			0
Navula Unslipped			0
Yacman Striated			0
Chen Mul Modeled			0
Mama Red			0
Unidentified	112	92	204
Total sherds	179	154	333

Table 4. Ceramics from Parcela Escolar

<u>Type</u>	2/1/1 (Op/Lev/Lot)	2/1/2	2/1/3	2/1/4	3/1/1	Total
Achiotes Unslipped						0
Yotolin Patterned Burnished			1			1
Chunhinta Black v. Ucu			1	3		4
Nacolal Incised			2	1		3
Dzocobel Red on Black						0
Joventud Red						0
Desvario Chamfered						0
Guitarra Incised						0
Dzudzuquil Cream to Buff			14	2		16
Tumben Incised						0
Majan Red on Cream						0
Tipikal Red on Striated						0
Unto Preslipped Striated Black						0
Chancenote Unslipped		1	3	4		8
Tancah Unslipped			1			1
Xanaba Red (LF)						0
Dzalpach Composite						0
Sierra Red		3	38	18		59
Laguna Verde Incised		1	12	6		19
Ciego Composite						0
Lagartos Punctate		1		1		2
Alta Mira Fluted						0
Repasto Black on Red						0
Flor Cream			2			2
Mateo Red on Cream						0
Polvero Black				1		1
Lechugal Incised				1		1
Saban Unslipped						0
Yaxcaba Striated						0
Xanaba Red	1					1
Caucel Trickle on Red						0
Tituc Orange Polychrome v. Tituc						0
Huachinango Bichrome Incised						0
Balanza Black			1			1
Lucha Incised						0
Aguila Orange			1			1
Dos Arroyos Orange Polychrome						0
Caldero Buff Polychrome						0
Cetelac Fiber Tempered						0
Elote Impressed						0
Yalchak Striated						0
Maxcanu Buff						0

Table 4. Ceramics from Parcela Escolar

<u>Type</u>	2/1/1 (Op / Lev / Lot)	2/1/2	2/1/3	2/1/4	3/1/1	Total
Hunabchen Red						0
Kanachen Black						0
Tituc Orange Polychrome v. Tituc						0
Tituc Orange Polychrome v. Bandas						0
Dos Caras Striated		1				1
Sacalaca Striated						0
Encanto Striated v. Sacna						0
Arena Red		2				2
Batres Red						0
Lakin Impressed						0
Muna Slate (LC)						0
Sacalum Black on Slate (LC)						0
Saxche Orange Polychrome						0
Juleki Cream Polychrome						0
Chantori Black on Orange						0
Sayan Red on Cream						0
Chum Unslipped				1		1
Yokat Striated	1	8	4	1	5	19
Oxkutzcab Applique						0
Muna Slate	1	3	8	6	3	21
Sacalum Black on Slate			2			2
Tekit Incised	1					1
Tekit Incised v. Dzib						0
Akil Impressed						0
Teabo Red	1				1	2
Becal Incised						0
Ticul Thin Slate						0
Tabi Gouged-Incised						0
Dzitas Slate						0
Balantun Black on Slate						0
Chacmay Incised						0
Piste Striated						0
Tohil Group						0
Navula Unslipped						0
Yacman Striated						0
Chen Mul Modeled						0
Mama Red						0
Unidentified	35	32	82	48	28	225
Total sherds	40	52	172	93	37	394

Table 5. Ceramics from Ramonal Oriente

<u>Type</u>	Surface (Op / Lev / Lot)	Surface	Total
Achiotes Unslipped			0
Chunhintá Black v. Ucu			0
Nacolal Incised			0
Dzocobel Red on Black			0
Joventud Red			0
Desvario Chamfered			0
Guitarra Incised			0
Dzudzuquil Cream to Buff			0
Tumben Incised			0
Majan Red on Cream			0
Tipikal Red on Striated			0
Unto Preslipped Striated Black			0
Chancenote Unslipped			0
Tancah Unslipped			0
Xanaba Red (LF)			0
Dzalpach Composite			0
Sierra Red			0
Laguna Verde Incised			0
Ciego Composite			0
Lagartos Punctate			0
Alta Mira Fluted			0
Repasto Black on Red			0
Flor Cream			0
Mateo Red on Cream			0
Polvero Black			0
Saban Unslipped			0
Yaxcaba Striated			0
Xanaba Red			0
Caucel Trickle on Red			0
Tituc Orange Polychrome v. Tituc			0
Huachinango Bichrome Incised			0
Balanza Black			0
Lucha Incised			0
Aguila Orange			0
Dos Arroyos Orange Polychrome			0
Caldero Buff Polychrome			0
Cetelac Fiber Tempered			0
Elote Impressed			0
Yalchak Striated			0
Maxcanu Buff			0

Table 5. Ceramics from Ramonal Oriente

<u>Type</u>	Sup (Op/Lev/Lot)	Sup	Total
Hunabchen Red			0
Kanachen Black			0
Tituc Orange Polychrome v. Tituc			0
Tituc Orange Polychrome v. Bandas			0
Dos Caras Striated			0
Sacalaca Striated			0
Encanto Striated v. Sacna			0
Arena Red			0
Batres Red			0
Lakin Impressed			0
Muna Slate (LC)			0
Sacalum Black on Slate (LC)			0
Saxche Orange Polychrome			0
Juleki Cream Polychrome			0
Chantori Black on Orange			0
Sayan Red on Cream			0
Chum Unslipped			0
Yokat Striated	1	1	2
Oxkutzcab Applique			0
Muna Slate	1	1	2
Sacalum Black on Slate			0
Tekit Incised			0
Xaya Gougged-incised		1	1
Tekit Incised v. Dzib			0
Akil Impressed			0
Teabo Red			0
Becal Incised			0
Ticul Thin Slate			0
Tabi Gougged-Incised			0
Dzitas Slate			0
Balantun Black on Slate			0
Chacmay Incised			0
Piste Striated			0
Tohil Group			0
Navula Unslipped			0
Yacman Striated			0
Chen Mul Modeled			0
Mama Red			0
Unidentified			0
Total sherds	2	3	5

Table 6. Ceramics from Ramonal Quemado

<u>Type</u>	1/1/1 (Op/Lev/Lot)	1/2/1	1/3/1	2/1/1	3/1/1
Achiotes Unslipped					
Chunhinta Black v. Ucu				2	
Nacolal Incised					
Dzocobel Red on Black					
Uchben Incised-dichrome					
Joventud Red					
Desvario Chamfered					
Guitarra Incised					
Dzudzuquil Cream to Buff	2				
Tumben Incised	3				
Majan Red on Cream					
Tipikal Red on Striated					
Unto Preslipped Striated Black					
Chancenote Unslipped	2			1	
Tancah Unslipped					
Xanaba Red (LF)					
Dzalpach Composite					
Sierra Red	3			1	3
Laguna Verde Incised	2				
Ciego Composite	1				
Lagartos Punctate					1
Alta Mira Fluted					
Repasto Black on Red					
Flor Cream					
Mateo Red on Cream					
Polvero Black	1				2
Saban Unslipped					
Yaxcaba Striated					
Xanaba Red					
Caucel Trickel on Red					
Tituc Orange Polychrome v. Tituc					
Huachinango Bichrome Incised					
Balanza Black					
Lucha Incised					
Aguila Orange					
Dos Arroyos Orange Polychrome	1				
Caldero Buff Polychrome					
Cetelac Fiber Tempered					
Elote Impressed					
Yalchak Striated					
Maxcanu Buff					

Table 6. Ceramics from Ramonal Quemado

<u>Type</u>	1/1/1 (Op/Lev/Lot)	1/2/1	1/3/1	2/1/1	3/1/1
Hunabchen Red					
Kankachen Black					
Tituc Orange Polychrome v. Tituc					
Tituc Orange Polychrome v. Bandas					
Dos Caras Striated					
Sacalaca Striated					
Encanto Striated v. Sacna					
Arena Red					
Batres Red					
Lakin Impressed					
Muna Slate (LC)					
Sacalum Black on Slate (LC)					
Saxche Orange Polychrome					
Juleki Cream Polychrome					
Chantori Black on Orange					
Sayan Red on Cream					
Chum Unslipped					
Yokat Striated					
Oxkutzcab Applique					
Muna Slate	13	1	1		1
Sacalum Black on Slate					
Tekit Incised					
Tekit Incised v. Dzib					
Akil Impressed					
Teabo Red					
Becal Incised					
Ticul Thin Slate					
Tabi Gouged-Incised					
Dzitas Slate					
Balantun Black on Slate					
Chacmay Incised					
Piste Striated					
Tohil Group					
Navula Unslipped					
Yacman Striated					
Chen Mul Modeled	2				
Mama Red					
Unidentified	27	0	9	1	6
Total sherds	57	1	14	1	13

Table 6. Ceramics from Ramonal Quemado

Type	4/3/1	4/4/1	5/1/4	5/2/1	5/3/1
Achiotes Unslipped					
Chunhinta Black v. Ucu	2				
Nacolal Incised				1	
Dzocobel Red on Black					
Uchben Incised-dichrome					
Joventud Red					
Desvario Chamfered					
Guitarra Incised					
Dzudzuquil Cream to Buff					
Tumben Incised					
Majan Red on Cream					
Tipikal Red on Striated					
Unto Preslipped Striated Black					
Chancenote Unslipped					
Tancah Unslipped					
Xanaba Red (LF)					
Dzalpach Composite					
Sierra Red	5		3		2
Laguna Verde Incised	1				
Ciego Composite					
Lagartos Punctate					
Alta Mira Fluted					
Repasto Black on Red					
Flor Cream					
Mateo Red on Cream					
Polvero Black					
Saban Unslipped					
Yaxcaba Striated					1
Xanaba Red		1			1
Caucel Trickel on Red					
Tituc Orange Polychrome v. Tituc					
Huachinango Bichrome Incised					
Balanza Black					
Lucha Incised					
Aguila Orange		1			
Dos Arroyos Orange Polychrome					
Caldero Buff Polychrome					
Cetelac Fiber Tempered					
Elote Impressed					
Yalchak Striated					
Maxcanu Buff					

Table 6. Ceramics from Ramonal Quemado

<u>Type</u>	4/3/1	4/4/1	5/1/4	5/2/1	5/3/1
Hunabchen Red					
Kankachen Black					
Tituc Orange Polychrome v. Tituc					
Tituc Orange Polychrome v. Bandas					
Dos Caras Striated					
Sacalaca Striated					
Encanto Striated v. Sacna					
Arena Red			1		
Batres Red					
Lakin Impressed					
Muna Slate (LC)					
Sacalum Black on Slate (LC)					
Saxche Orange Polychrome					
Juleki Cream Polychrome					
Chantori Black on Orange					
Sayan Red on Cream					
Chum Unslipped					
Yokat Striated					
Oxkutzcab Applique					
Muna Slate			15	4	
Sacalum Black on Slate					
Tekit Incised					
Tekit Incised v. Dzib					
Akil Impressed					
Teabo Red			1	2	
Becal Incised					
Ticul Thin Slate				1	
Tabi Gouged-Incised					
Dzitas Slate					
Balantun Black on Slate					
Chacmay Incised					
Piste Striated					
Tohil Group					
Navula Unslipped					
Yacman Striated					
Chen Mul Modeled			4		
Mama Red					
Unidentified	13	2	75	16	5
Total sherds	21	4	99	24	9

Table 6. Ceramics from Ramonal Quemado

Type	5/3/2	5/4/1	5/5/1	5/6/1	Total
Achiotes Unslipped					0
Chunhinta Black v. Ucu					3
Nacolal Incised					0
Dzocobel Red on Black					0
Uchben Incised-dichrome					0
Joventud Red				1	0
Desvario Chamfered					0
Guitarra Incised				2	0
Dzudzuquil Cream to Buff					2
Tumben Incised					3
Majan Red on Cream					0
Tipikal Red on Striated					0
Unto Preslipped Striated Black					0
Chancenote Unslipped					3
Tancah Unslipped					0
Xanaba Red (LF)					0
Dzalpach Composite					0
Sierra Red	1		2	1	10
Laguna Verde Incised					2
Ciego Composite					1
Lagartos Punctate					2
Alta Mira Fluted					0
Repasto Black on Red					0
Flor Cream					0
Mateo Red on Cream					0
Polvero Black					3
Saban Unslipped					0
Yaxcaba Striated				2	0
Xanaba Red					1
Caucel Trickle on Red					0
Tituc Orange Polychrome v. Tituc					0
Huachinango Bichrome Incised					0
Balanza Black					0
Lucha Incised				1	0
Aguila Orange					0
Dos Arroyos Orange Polychrome					1
Caldero Buff Polychrome					0
Cetelac Fiber Tempered					0
Elote Impressed					0
Yalchak Striated					0
Maxcanu Buff					0

Table 6. Ceramics from Ramonal Quemado

<u>Type</u>	5/3/2	5/4/1	5/5/1	5/6/1	Total
Hunabchen Red					0
Kankachen Black					0
Tituc Orange Polychrome v. Tituc					0
Tituc Orange Polychrome v. Bandas					0
Dos Caras Striated					0
Sacalaca Striated					0
Encanto Striated v. Sacna					0
Arena Red					1
Batres Red					0
Lakin Impressed					0
Muna Slate (LC)					0
Sacalum Black on Slate (LC)					0
Saxche Orange Polychrome					0
Juleki Cream Polychrome					0
Chantori Black on Orange					0
Sayan Red on Cream					0
Chum Unslipped					0
Yokat Striated	3				4
Oxkutzcab Applique					0
Muna Slate		2			25
Sacalum Black on Slate					0
Tekit Incised					0
Tekit Incised v. Dzib					0
Akil Impressed					0
Teabo Red	3	1			5
Becal Incised					0
Ticul Thin Slate					0
Tabi Gougged-Incised					0
Dzitas Slate					0
Balantun Black on Slate					0
Chacmay Incised					0
Piste Striated					0
Tohil Group					0
Navula Unslipped					0
Yacman Striated					0
Chen Mul Modeled					2
Mama Red					0
Unidentified			6	8	72
Total sherds		3	8	15	140

Table 7. Ceramics from Sahcabchen

Type	1/1/1 (Op/Lev/Lot)	1/2/1	1/2/2	1/3/1	2/2/1
Achiotes Unslipped					
Chunhinta Black v. Ucu				1	
Nacolal Incised					
Dzocobel Red on Black					
Joventud Red					
Desvario Chamfered					
Guitarra Incised					
Dzudzuquil Cream to Buff					
Tumben Incised					
Majan Red on Cream					
Tipikal Red on Striated					
Unto Preslipped Striated Black					
Chancenote Unslipped					
Tancah Unslipped					
Xanaba Red (LF)					
Dzalpach Composite					
Sierra Red	3	5	5		
Laguna Verde Incised		1			
Ciego Composite					
Lagartos Punctate					
Alta Mira Fluted					
Repasto Black on Red					
Flor Cream					
Mateo Red on Cream					
Polvero Black					
Saban Unslipped					
Yaxcaba Striated					
Xanaba Red					
Caucel Trickel on Red		1			
Tituc Orange Polychrome v. Tituc					
Huachinango Bichrome Incised					
Balanza Black					
Lucha Incised					
Aguila Orange					
Dos Arroyos Orange Polychrome				1	
Caldero Buff Polychrome					
Cetelac Fiber Tempered					
Elote Impressed					
Yalchak Striated					
Maxcanu Buff					

Table 7. Ceramics from Sahcabchen

Type	1/1/1 (Op/Lev/Lot)	1/2/1	1/2/2	1/3/1	2/2/1
Hunabchen Red					
Kankachen Black					
Tituc Orange Polychrome v. Tituc					
Tituc Orange Polychrome v. Bandas					
Dos Caras Striated					
Sacalaca Striated					
Encanto Striated v. Sacna				1	
Arena Red				3	
Batres Red					
Lakin Impressed					
Muna Slate (LC)				1	
Sacalum Black on Slate (LC)					
Saxche Orange Polychrome					
Juleki Cream Polychrome					
Chantori Black on Orange					
Sayan Red on Cream					
Chum Unslipped					
Yokat Striated	4	10	5	6	
Oxkutzcab Applique					
Muna Slate	2	3	8	5	
Sacalum Black on Slate		1			
Tekit Incised				1	
Tekit Incised v. Dzib					
Akil Impressed					
Teabo Red		2	2		
Becal Incised					
Ticul Thin Slate					
Tabi Gouged-Incised					
Dzitas Slate					
Balantun Black on Slate					
Chacmay Incised					
Piste Striated					
Tohil Group					
Navula Unslipped					
Yacman Striated					
Chen Mul Modeled					
Mama Red					
Unidentified	17	70	48	28	3
Total sherds	26	93	68	47	3

Table 7. Ceramics from Sahcabchen

<u>Type</u>	2/3/1	3/1/1	3/2/1	3/3/1	3/3/2
Achiotes Unslipped					
Chunhinta Black v. Ucu					2
Nacolal Incised	1				
Dzocobel Red on Black					
Joventud Red					
Desvario Chamfered					
Guitarra Incised					
Dzudzuquil Cream to Buff	1				
Tumben Incised					
Majan Red on Cream					
Tipikal Red on Striated					
Unto Preslipped Striated Black					
Chancenote Unslipped					
Tancah Unslipped					
Xanaba Red (LF)					
Dzalpach Composite					
Sierra Red	1	1		5	10
Laguna Verde Incised					2
Ciego Composite					
Lagartos Punctate					
Alta Mira Fluted					
Repasto Black on Red				1	
Flor Cream					
Mateo Red on Cream					
Polvero Black					
Saban Unslipped					
Yaxcaba Striated					
Xanaba Red					
Caucel Trickle on Red					
Tituc Orange Polychrome v. Tituc					
Huachinango Bichrome Incised					
Balanza Black					1
Lucha Incised					
Aguila Orange					
Dos Arroyos Orange Polychrome					
Caldero Buff Polychrome					
Cetelac Fiber Tempered					3
Elote Impressed					
Yalchak Striated					
Maxcanu Buff					

Table 7. Ceramics from Sahcabchen

<u>Type</u>	2/3/1	3/1/1	3/2/1	3/3/1	3/3/2
Hunabchen Red					
Kanachen Black					
Tituc Orange Polychrome v. Tituc					
Tituc Orange Polychrome v. Bandas					
Dos Caras Striated					
Sacalaca Striated					
Encanto Striated v. Sacna					
Arena Red					1
Batres Red					
Lakin Impressed					
Muna Slate (LC)					
Sacalum Black on Slate (LC)					
Saxche Orange Polychrome					
Juleki Cream Polychrome					
Chantori Black on Orange					
Sayan Red on Cream					
Chum Unslipped					
Yokat Striated			2	4	8
Oxkutzcab Applique					
Muna Slate	2		4	4	1
Sacalum Black on Slate					
Tekit Incised					
Tekit Incised v. Dzib					
Akil Impressed					
Teabo Red					
Becal Incised					
Ticul Thin Slate				1	1
Tabi Gouged-Incised					
Dzitas Slate					
Balantun Black on Slate					
Chacmay Incised					
Piste Striated					
Tohil Group					
Navula Unslipped					
Yacman Striated					
Chen Mul Modeled			1		
Mama Red					
Unidentified	25	6	46	50	43
Total sherds	30	7	54	64	72

Table 7. Ceramics from Sahcabchen

<u>Type</u>	3/4/1	Total
Achiotes Unslipped		0
Chunhinta Black v. Ucu	1	4
Nacolal Incised		1
Dzocobel Red on Black		0
Joventud Red		0
Desvario Chamfered		0
Guitarra Incised		0
Dzudzuquil Cream to Buff	1	2
Tumben Incised	1	1
Majan Red on Cream		0
Tipikal Red on Striated		0
Unto Preslipped Striated Black		0
Chancenote Unslipped	2	2
Tancah Unslipped		0
Xanaba Red (LF)		0
Dzalpach Composite		0
Sierra Red	3	33
Laguna Verde Incised		3
Ciego Composite		0
Lagartos Punctate		0
Alta Mira Fluted		0
Repasto Black on Red		1
Flor Cream		0
Mateo Red on Cream		0
Polvero Black	1	1
Saban Unslipped		0
Yaxcaba Striated		0
Xanaba Red		0
Caucel Trickle on Red		1
Tituc Orange Polychrome v. Tituc		0
Huachinango Bichrome Incised		0
Balanza Black		1
Lucha Incised		0
Aguila Orange		0
Dos Arroyos Orange Polychrome		1
Caldero Buff Polychrome		0
Cetelac Fiber Tempered		3
Elote Impressed		0
Yalchak Striated		0
Maxcanu Buff		0

Table 7. Ceramics from Sahcabchen

<u>Type</u>	3/4/1	Total
Hunabchen Red		0
Kanachen Black		0
Tituc Orange Polychrome v. Tituc		0
Tituc Orange Polychrome v. Bandas		0
Dos Caras Striated		0
Sacalaca Striated		0
Encanto Striated v. Sacna		1
Arena Red		4
Batres Red		0
Lakin Impressed		0
Muna Slate (LC)		1
Sacalum Black on Slate (LC)		0
Saxche Orange Polychrome		0
Juleki Cream Polychrome		0
Chantori Black on Orange		0
Sayan Red on Cream		0
Chum Unslipped		0
Yokat Striated		39
Oxkutzcab Applique		0
Muna Slate		29
Sacalum Black on Slate		1
Tekit Incised		1
Tekit Incised v. Dzib		0
Akil Impressed		0
Teabo Red		4
Becal Incised		0
Ticul Thin Slate		2
Tabi Gougged-Incised		0
Dzitas Slate		0
Balantun Black on Slate		0
Chacmay Incised		0
Piste Striated		0
Tohil Group		0
Navula Unslipped		0
Yacman Striated		0
Chen Mul Modeled		1
Mama Red		0
Unidentified	19	355

Table 8. Ceramics from San Felipe

<u>Type</u>	2/1/1 (Op/Lev/Lot)	2/1&2/1	2/2/1	2/3/1	2/4/1
Achiotes Unslipped					
Chunhinta Black v. Ucu				3	
Nacolal Incised				1	2
Dzocobel Red on Black					
Joventud Red					
Desvario Chamfered					
Guitarra Incised					
Dzudzuquil Cream to Buff				3	1
Tumben Incised					1
Majan Red on Cream					
Canaima Incised-dichrome					
Tipikal Red on Striated					
Unto Preslipped Striated Black					
Chancenote Unslipped	1				1
Tancah Unslipped					
Xanaba Red (LF)					
Dzalpach Composite					
Sierra Red	1	3	2	16	49
Laguna Verde Incised				2	2
Ciego Composite					
Lagartos Punctate					
Alta Mira Fluted					
Repasto Black on Red					
Flor Cream					
Mateo Red on Cream					
Polvero Black				2	
Lechugal Incised					
Saban Unslipped					
Yaxcaba Striated				2	6
Xanaba Red			4	7	7
Caucel Trickel on Red			1		
Tituc Orange Polychrome v. Tituc					
Huachinango Bichrome Incised					
Balanza Black			3	2	5
Lucha Incised					
Aguila Orange			1	1	1
San Blas Red on Orange				1	
Dos Arroyos Orange Polychrome			1	2	1
Caldero Buff Polychrome					
Cetelac Fiber Tempered					
Elote Impressed					
Yalchak Striated					
Maxcanu Buff				1	

Table 8. Ceramics from San Felipe

<u>Type</u>	2/1/1 (Op/Lev/Lot)	2/1&2/1	2/2/1	2/3/1	2/4/1
Maxcanu Buff				1	
Hunabchen Red					
Kanachen Black					
Tituc Orange Polychrome v. Tituc					
Tituc Orange Polychrome v. Bandas					
Dos Caras Striated			1		
Sacalaca Striated					
Encanto Striated v. Sacna					
Arena Red	1		2		
Batres Red					
Lakin Impressed					
Muna Slate (LC)					
Sacalum Black on Slate (LC)					
Saxche Orange Polychrome			2		
Juleki Cream Polychrome					
Chantori Black on Orange					
Sayan Red on Cream					
Chum Unslipped					
Yokat Striated	221	81	184	94	27
Oxkutzcab Applique					
Muna Slate	88	18	54	37	32
Sacalum Black on Slate	4	1	3	4	1
Tekit Incised	1				
Tekit Incised v. Dzib					
Akil Impressed					
Nohcacab Composite			1		
Teabo Red	5	2	4	2	
Becal Incised	1				1
Ticul Thin Slate	9		7	4	1
Tabi Gouged-Incised					
Dzitas Slate					
Balantun Black on Slate					
Chacmay Incised					
Piste Striated					
Tohil Group					
Navula Unslipped					
Yacman Striated			2		
Chen Mul Modeled					
Mama Red			1		
Unidentified	123	47	70	8	161
Total sherds	455	152	343	192	299

Table 8. Ceramics from San Felipe

<u>Type</u>	3/1/1	3/1/2	3/2/1	3/3/1	4/1/1
Achiotes Unslipped					
Chunhintá Black v. Ucu				1	
Nacolal Incised				1	
Dzocobel Red on Black					
Joventud Red					
Desvario Chamfered					
Guitarra Incised					
Dzudzuquil Cream to Buff					
Tumben Incised				3	
Majan Red on Cream					
Canaima Incised-dichrome					
Tipikal Red on Striated					
Unto Preslipped Striated Black					
Chancenote Unslipped				1	
Tancah Unslipped					
Xanaba Red (LF)					
Dzalpach Composite					
Sierra Red	1		1		8
Laguna Verde Incised			1		2
Ciego Composite					
Lagartos Punctate					
Alta Mira Fluted					
Repasto Black on Red					
Flor Cream					
Mateo Red on Cream					
Polvero Black				1	
Lechugal Incised					
Saban Unslipped					
Yaxcaba Striated					
Xanaba Red					
Caucel Trickel on Red					
Tituc Orange Polychrome v. Tituc					
Huachinango Bichrome Incised					
Balanza Black					
Lucha Incised					
Aguila Orange					
San Blas Red on Orange					
Dos Arroyos Orange Polychrome					
Caldero Buff Polychrome					
Cetelac Fiber Tempered					
Elote Impressed					
Yalchak Striated					

Table 8. Ceramics from San Felipe

<u>Type</u>	3/1/1	3/1/2	3/2/1	3/3/1	4/1/1
Maxcanu Buff					
Hunabchen Red					
Kanachen Black					
Tituc Orange Polychrome v. Tituc					
Tituc Orange Polychrome v. Bandas					
Dos Caras Striated					
Sacalaca Striated					
Encanto Striated v. Sacna					
Arena Red					
Batres Red					
Lakin Impressed					
Muna Slate (LC)					
Sacalum Black on Slate (LC)					
Saxche Orange Polychrome					
Juleki Cream Polychrome					
Chantori Black on Orange					
Sayan Red on Cream					
Chum Unslipped					
Yokat Striated	4		3		7
Oxkutzcab Applique					
Muna Slate	4		7		3
Sacalum Black on Slate					
Tekit Incised					
Tekit Incised v. Dzib					
Akil Impressed					
Nohcacab Composite					
Teabo Red					
Becal Incised					
Ticul Thin Slate	1				
Tabi Gouged-Incised					
Dzitas Slate					
Balantun Black on Slate					
Chacmay Incised					
Piste Striated					
Tohil Group					
Navula Unslipped					
Yacman Striated					
Chen Mul Modeled	1				
Mama Red					
Unidentified	21	5	19	32	59
Total sherds	32	5	31	49	69

Table 8. Ceramics from San Felipe

<u>Type</u>	4/2/1	4/3/1&2	4/3/3	4/4/1	4/5/1
Achiotes Unslipped					
Chunhintá Black v. Ucu			1		
Nacolal Incised					
Dzocobel Red on Black					
Joventud Red					
Desvario Chamfered					
Guitarra Incised					
Dzudzuquil Cream to Buff			2		
Tumben Incised					
Majan Red on Cream					
Canaima Incised-dichrome					
Tipikal Red on Striated					
Unto Preslipped Striated Black					
Chancenote Unslipped				1	
Tancah Unslipped					
Xanaba Red (LF)					
Dzalpach Composite					
Sierra Red			9	15	
Laguna Verde Incised			3		
Ciego Composite					
Lagartos Punctate					
Alta Mira Fluted					
Repasto Black on Red		1		1	
Flor Cream					
Mateo Red on Cream					
Polvero Black					
Lechugal Incised					
Saban Unslipped					
Yaxcaba Striated			2		
Xanaba Red	3	4	6	5	1
Caucel Trickel on Red					
Tituc Orange Polychrome v. Tituc	1				
Huachinango Bichrome Incised					
Balanza Black			1		
Lucha Incised					
Aguila Orange					
San Blas Red on Orange					
Dos Arroyos Orange Polychrome	1	4			
Caldero Buff Polychrome					
Cetelac Fiber Tempered					
Elote Impressed					
Yalchak Striated					

Table 8. Ceramics from San Felipe

<u>Type</u>	4/2/1	4/3/1&2	4/3/3	4/4/1	4/5/1
Maxcanu Buff					
Hunabchen Red					
Kanachen Black					
Tituc Orange Polychrome v. Tituc					
Tituc Orange Polychrome v. Bandas					
Dos Caras Striated		3			
Sacalaca Striated					
Encanto Striated v. Sacna					
Arena Red					
Batres Red					
Lakin Impressed					
Muna Slate (LC)					
Sacalum Black on Slate (LC)					
Saxche Orange Polychrome					
Juleki Cream Polychrome					
Chantori Black on Orange					
Sayan Red on Cream					
Chum Unslipped					
Yokat Striated	8	10		3	
Oxkutzcab Applique					
Muna Slate	3	4		9	
Sacalum Black on Slate				1	
Tekit Incised					
Tekit Incised v. Dzib					
Akil Impressed					
Nohcacab Composite					
Teabo Red	2	1		3	
Becal Incised					
Ticul Thin Slate					
Tabi Gouged-Incised					
Dzitas Slate					
Balantun Black on Slate					
Chacmay Incised					
Piste Striated					
Tohil Group					
Navula Unslipped					
Yacman Striated					
Chen Mul Modeled					
Mama Red					
Unidentified	33	25	3	27	1
Total sherds	51	52	27	65	2

Table 8. Ceramics from San Felipe

Type	4/5/2	4/7/1	4/9/1	5/1/1	5/2/1	5/3/1
Achiotes Unslipped	2					
Chunhinta Black v. Ucu		9	4			
Nacolal Incised		1				
Dzocobel Red on Black						
Joventud Red						
Desvario Chamfered						
Guitarra Incised						
Dzudzuquil Cream to Buff	16	4	6			
Tumben Incised			5			
Majan Red on Cream						
Canaima Incised-dichrome			1			
Tipikal Red on Striated						
Unto Preslipped Striated Black	1					
Chancenote Unslipped	3	3	2			
Tancah Unslipped						
Xanaba Red (LF)						
Dzalpach Composite						
Sierra Red	77	69	11	1		
Laguna Verde Incised	3	6	5			
Ciego Composite						
Lagartos Punctate						
Alta Mira Fluted						
Repasto Black on Red						
Flor Cream						
Mateo Red on Cream						
Polvero Black		4	2			
Lechugal Incised	1					
Saban Unslipped						
Yaxcaba Striated						
Xanaba Red	21	3			7	10
Caucel Trickel on Red						
Tituc Orange Polychrome v. Tituc				1		3
Huachinango Bichrome Incised						
Balanza Black						
Lucha Incised						
Aguila Orange						
San Blas Red on Orange						
Dos Arroyos Orange Polychrome					2	
Caldero Buff Polychrome						
Cetelac Fiber Tempered						
Elote Impressed						
Yalchak Striated						

Table 8. Ceramics from San Felipe

<u>Type</u>	4/5/2	4/7/1	4/9/1	5/1/1	5/2/1	5/3/1
Maxcanu Buff						
Hunabchen Red						
Kanachen Black						
Tituc Orange Polychrome v. Tituc						
Tituc Orange Polychrome v. Bandas						
Dos Caras Striated						
Sacalaca Striated						
Encanto Striated v. Sacna						
Arena Red						
Batres Red						
Lakin Impressed						
Muna Slate (LC)						
Sacalum Black on Slate (LC)						
Saxche Orange Polychrome						
Juleki Cream Polychrome						
Chantori Black on Orange						
Sayan Red on Cream						
Chum Unslipped				6		
Yokat Striated				7	22	9
Oxkutzcab Applique						
Muna Slate				20	6	19
Sacalum Black on Slate						
Tekit Incised				3		
Tekit Incised v. Dzib						
Akil Impressed						
Nohcacab Composite						
Teabo Red				5	1	4
Becal Incised						
Ticul Thin Slate						
Tabi Gouged-Incised						
Dzitas Slate						
Balantun Black on Slate						
Chacmay Incised						
Piste Striated						
Tohil Group						
Navula Unslipped						
Yacman Striated						
Chen Mul Modeled					1	
Mama Red						
Unidentified	58	71	48	57	72	4
Total sherds	181	170	125	89	113	17

Table 8. Ceramics from San Felipe

Type	5/3/3	5/4/1	5/5/2	5/6/1	5/7/1	5/8/1
Achiotes Unslipped						
Chunhinta Black v. Ucu				4		
Nacolal Incised		1				
Dzocobel Red on Black			1			
Joventud Red		1	1		1	
Desvario Chamfered						
Guitarra Incised						
Dzudzuquil Cream to Buff		2	4	1		
Tumben Incised			1			
Majan Red on Cream						
Canaima Incised-dichrome						
Tipikal Red on Striated						
Unto Preslipped Striated Black						
Chancenote Unslipped				1		
Tancah Unslipped						
Xanaba Red (LF)						2
Dzalpach Composite						
Sierra Red	4	4	10	8	9	8
Laguna Verde Incised						
Ciego Composite						
Lagartos Punctate						
Alta Mira Fluted						
Repasto Black on Red						
Flor Cream						
Mateo Red on Cream						
Polvero Black			1			
Lechugal Incised						
Saban Unslipped						
Yaxcaba Striated	1					
Xanaba Red	2	1				
Caucel Trickel on Red						
Tituc Orange Polychrome v. Tituc		1				
Huachinango Bichrome Incised						
Balanza Black						
Lucha Incised						
Aguila Orange						
San Blas Red on Orange						
Dos Arroyos Orange Polychrome						
Caldero Buff Polychrome						
Cetelac Fiber Tempered						
Elote Impressed						
Yalchak Striated						

Table 8. Ceramics from San Felipe

<u>Type</u>	5/3/3	5/4/1	5/5/2	5/6/1	5/7/1	5/8/1
Maxcanu Buff						
Hunabchen Red						
Kanachen Black						
Tituc Orange Polychrome v. Tituc						
Tituc Orange Polychrome v. Bandas						
Dos Caras Striated						
Sacalaca Striated						
Encanto Striated v. Sacna						
Arena Red						
Batres Red						
Lakin Impressed						
Muna Slate (LC)						
Sacalum Black on Slate (LC)						
Saxche Orange Polychrome						
Juleki Cream Polychrome						
Chantori Black on Orange						
Sayan Red on Cream						
Chum Unslipped						
Yokat Striated						
Oxkutzcab Applique						
Muna Slate						
Sacalum Black on Slate						
Tekit Incised						
Tekit Incised v. Dzib						
Akil Impressed						
Nohcacab Composite						
Teabo Red						
Becal Incised						
Ticul Thin Slate						
Tabi Gouged-Incised						
Dzitas Slate						
Balantun Black on Slate						
Chacmay Incised						
Piste Striated						
Tohil Group						
Navula Unslipped						
Yacman Striated						
Chen Mul Modeled						
Mama Red						
Unidentified	1	7	8	14	3	
Total sherds	8	17	26	28	15	8

Table 8. Ceramics from San Felipe

<u>Type</u>	Total
Achiotes Unslipped	2
Chunhinta Black v. Ucu	22
Nacolal Incised	6
Dzocobel Red on Black	1
Joventud Red	3
Desvario Chamfered	0
Guitarra Incised	0
Dzudzuquil Cream to Buff	39
Tumben Incised	10
Majan Red on Cream	0
Canaima Incised-dichrome	1
Tipikal Red on Striated	0
Unto Preslipped Striated Black	0
Chancenote Unslipped	13
Tancah Unslipped	0
Xanaba Red (LF)	2
Dzalpach Composite	0
Sierra Red	306
Laguna Verde Incised	24
Ciego Composite	0
Lagartos Punctate	0
Alta Mira Fluted	0
Repasto Black on Red	2
Flor Cream	0
Mateo Red on Cream	0
Polvero Black	10
Lechugal Incised	1
Saban Unslipped	0
Yaxcaba Striated	11
Xanaba Red	81
Caucel Trickel on Red	1
Tituc Orange Polychrome v. Tituc	6
Huachinango Bichrome Incised	0
Balanza Black	11
Lucha Incised	0
Aguila Orange	3
San Blas Red on Orange	1
Dos Arroyos Orange Polychrome	11
Caldero Buff Polychrome	0
Cetelac Fiber Tempered	0
Elote Impressed	0
Yalchak Striated	0

Table 8. Ceramics from San Felipe

<u>Type</u>	Total
Maxcanu Buff	1
Hunabchen Red	0
Kanachen Black	0
Tituc Orange Polychrome v. Tituc	0
Tituc Orange Polychrome v. Bandas	0
Dos Caras Striated	4
Sacalaca Striated	0
Encanto Striated v. Sacna	0
Arena Red	3
Batres Red	0
Lakin Impressed	0
Muna Slate (LC)	0
Sacalum Black on Slate (LC)	0
Saxche Orange Polychrome	2
Juleki Cream Polychrome	0
Chantori Black on Orange	0
Sayan Red on Cream	0
Chum Unslipped	6
Yokat Striated	680
Oxkutzcab Applique	0
Muna Slate	304
Sacalum Black on Slate	14
Tekit Incised	4
Tekit Incised v. Dzib	0
Akil Impressed	0
Nohcacab Composite	1
Teabo Red	29
Becal Incised	2
Ticul Thin Slate	22
Tabi Gougged-Incised	0
Dzitas Slate	0
Balantun Black on Slate	0
Chacmay Incised	0
Piste Striated	0
Tohil Group	0
Navula Unslipped	0
Yacman Striated	2
Chen Mul Modeled	2
Mama Red	1
Unidentified	977
Total sherds	2621

Table 9. Ceramics from San Lorenzo

<u>Type</u>	1/1/1 (Op/Lev/Lot)	1/2/1	1/3/1	1/5/1	2/1/1
Achiotes Unslipped					
Yotolin Patterned Burnished					
Chunhintá Black v. Ucu				2	
Nacolal Incised					
Dzocobel Red on Black					
Uchben Incised dichrome					
Joventud Red					
Desvario Chamfered					
Guitarra Incised					
Dzudzuquil Cream to Buff				1	
Tumben Incised				1	
Petjal Red on Black and Cream					
Majan Red on Cream					
Canaima Incised dichrome					
Loche Incised dichrome					
Tipikal Red on Striated					
Unto Preslipped Striated Black					
Chancenote Unslipped					
Tancah Unslipped					
Xanaba Red (LF)			2		
Dzalpach Composite					
Sierra Red	1			6	
Laguna Verde Incised					
Laguan Verde v. resist			1		
Ciego Composite					
Lagartos Punctate					
Alta Mira Fluted					
Repasto Black on Red					
Flor Cream					
Mateo Red on Cream					
Polvero Black					
Lechugal Incised					
Saban Unslipped					
Yaxcaba Striated		1			
Xanaba Red					1
Caucel Trickel on Red					
Tituc Orange Polychrome v. Tituc					
Huachinango Bichrome Incised					
Balanza Black				7	
Lucha Incised					
Aguila Orange					
Dos Arroyos Orange Polychrome				5	
Caldero Buff Polychrome					
Cetelac Fiber Tempered					
Elote Impressed					
Yalchak Striated					

Table 9. Ceramics from San Lorenzo

<u>Type</u>	1/1/1 (Op/Lev/Lot)	1/2/1	1/3/1	1/5/1	2/1/1
Maxcanu Buff					
Hunabchen Red					
Kanachen Black					
Tituc Orange Polychrome v. Tituc					
Tituc Orange Polychrome v. Bandas					
Dos Caras Striated					
Sacalaca Striated					
Encanto Striated v. Sacna					
Arena Red					
Batres Red					
Lakin Impressed					
Muna Slate (LC)					
Sacalum Black on Slate (LC)					
Saxche Orange Polychrome					
Juleki Cream Polychrome					
Chantori Black on Orange					
Sayan Red on Cream					
Chum Unslipped					
Yokat Striated	31	21	20	7	11
Oxkutzcab Applique					
Muna Slate	10	9	11	1	10
Sacalum Black on Slate	1		1		
Tekit Incised	1				
Tekit Incised v. Dzib					
Akil Impressed		1	2		
Teabo Red	2		1		3
Becal Incised					
Ticul Thin Slate		1	1		
Tabi Gouged-Incised		1			
Dzitas Slate					
Balantun Black on Slate			1		
Chacmay Incised					
Piste Striated					
Tohil Group					
Navula Unslipped					
Yacman Striated	1				
Chen Mul Modeled	5				4
Mama Red					
Unidentified	29	29	65	20	48
Total sherds	81	63	105	50	77

Table 9. Ceramics from San Lorenzo

Type	2/2/1	2/3/1	2/3/2	2/4/1	2/4/2
Achiotes Unslipped				4	
Yotolin Patterned Burnished					
Chunhinta Black v. Ucu		1	1		
Nacolal Incised				3	
Dzocobel Red on Black					
Uchben Incised dichrome					
Joventud Red					
Desvario Chamfered					
Guitarra Incised					
Dzudzuquil Cream to Buff		1		24	
Tumben Incised				7	1
Petjal Red on Black and Cream					
Majan Red on Cream					
Canaima Incised dichrome				4	
Loche Incised dichrome				1	
Tipikal Red on Striated					
Unto Preslipped Striated Black					
Chancenote Unslipped				4	
Tancah Unslipped					
Xanaba Red (LF)					
Dzalpach Composite					
Sierra Red				5	
Laguna Verde Incised			1	4	1
Laguan Verde v. resist					
Ciego Composite				1	
Lagartos Punctate					
Alta Mira Fluted					
Repasto Black on Red					
Flor Cream				1	
Mateo Red on Cream					
Polvero Black				10	
Lechugal Incised					
Saban Unslipped				1	
Yaxcaba Striated					
Xanaba Red		1			
Caucel Trickel on Red		1			
Tituc Orange Polychrome v. Tituc					
Huachinango Bichrome Incised					
Balanza Black		1			
Lucha Incised					
Aguila Orange					
Dos Arroyos Orange Polychrome	1				
Caldero Buff Polychrome					
Cetelac Fiber Tempered					
Elote Impressed					
Yalchak Striated					

Table 9. Ceramics from San Lorenzo

<u>Type</u>	2/2/1	2/3/1	2/3/2	2/4/1	2/4/2
Maxcanu Buff					
Hunabchen Red					
Kanachen Black					
Tituc Orange Polychrome v. Tituc					
Tituc Orange Polychrome v. Bandas					
Dos Caras Striated					
Sacalaca Striated					
Encanto Striated v. Sacna					
Arena Red					
Batres Red					
Lakin Impressed					
Muna Slate (LC)					
Sacalum Black on Slate (LC)					
Saxche Orange Polychrome					
Juleki Cream Polychrome					
Chantori Black on Orange					
Sayan Red on Cream					
Chum Unslipped					
Yokat Striated	4	1	1		
Oxkutzcab Applique					
Muna Slate	2	3	1		
Sacalum Black on Slate					
Tekit Incised					
Tekit Incised v. Dzib					
Akil Impressed					
Teabo Red					
Becal Incised					
Ticul Thin Slate					
Tabi Gougged-Incised					
Dzitas Slate					
Balantun Black on Slate					
Chacmay Incised					
Piste Striated					
Tohil Group					
Navula Unslipped					
Yacman Striated					
Chen Mul Modeled	2				
Mama Red					
Unidentified	14	23	14	63	2
Total sherds	23	32	18	132	4

Table 9. Ceramics from San Lorenzo

Type	2/5/1	3/1/1	3/2/1	3/3/1	3/4/2
Achiotes Unslipped					
Yotolin Patterned Burnished					
Chunhinta Black v. Ucu				2	
Nacolal Incised					
Dzocobel Red on Black					
Uchben Incised dichrome					
Joventud Red					
Desvario Chamfered					
Guitarra Incised					
Dzudzuquil Cream to Buff	3				
Tumben Incised					
Petjal Red on Black and Cream					
Majan Red on Cream					
Canaima Incised dichrome					
Loche Incised dichrome					
Tipikal Red on Striated					
Unto Preslipped Striated Black					
Chancenote Unslipped					
Tancah Unslipped					
Xanaba Red (LF)					
Dzalpach Composite					
Sierra Red	2	1		2	5
Laguna Verde Incised					2
Laguan Verde v. resist					
Ciego Composite					
Lagartos Punctate					
Alta Mira Fluted					
Repasto Black on Red					
Flor Cream					
Mateo Red on Cream					
Polvero Black	1				
Lechugal Incised					
Saban Unslipped					
Yaxcaba Striated					
Xanaba Red					
Caucel Trickel on Red					
Tituc Orange Polychrome v. Tituc					
Huachinango Bichrome Incised					
Balanza Black				1	
Lucha Incised					
Aguila Orange					
Dos Arroyos Orange Polychrome					
Caldero Buff Polychrome					
Cetelac Fiber Tempered					
Elote Impressed					
Yalchak Striated					

Table 9. Ceramics from San Lorenzo

<u>Type</u>	2/5/1	3/1/1	3/2/1	3/3/1	3/4/2
Maxcanu Buff					
Hunabchen Red					
Kanachen Black					
Tituc Orange Polychrome v. Tituc					
Tituc Orange Polychrome v. Bandas					
Dos Caras Striated			2		
Sacalaca Striated					
Encanto Striated v. Sacna					
Arena Red					
Batres Red					
Lakin Impressed					
Muna Slate (LC)					
Sacalum Black on Slate (LC)					
Saxche Orange Polychrome					
Juleki Cream Polychrome					
Chantori Black on Orange					
Sayan Red on Cream					
Chum Unslipped					
Yokat Striated		2	5	5	5
Oxkutzcab Applique					
Muna Slate		2	1	5	7
Sacalum Black on Slate					
Tekit Incised				1	
Tekit Incised v. Dzib					
Akil Impressed					
Teabo Red		1	1	1	
Becal Incised					
Ticul Thin Slate					
Tabi Gougged-Incised					
Dzitas Slate					
Balantun Black on Slate					
Chacmay Incised					
Piste Striated					
Tohil Group					
Navula Unslipped					
Yacman Striated					
Chen Mul Modeled					
Mama Red					
Unidentified		13	5	14	28
Total sherds	6	19	15	30	47

Table 9. Ceramics from San Lorenzo

Type	3/5/1	3/6/1	3/7/1	4/2&3/1	4/3/2
Achiotes Unslipped					
Yotolin Patterned Burnished					
Chunhinta Black v. Ucu	1				
Nacolal Incised			1		
Dzocobel Red on Black					
Uchben Incised dichrome					
Joventud Red					
Desvario Chamfered					
Guitarra Incised					
Dzudzuquil Cream to Buff		3	1	1	
Tumben Incised					
Petjal Red on Black and Cream					
Majan Red on Cream					
Canaima Incised dichrome					
Loche Incised dichrome					
Tipikal Red on Striated					
Unto Preslipped Striated Black					
Chancenote Unslipped					3
Tancah Unslipped					
Xanaba Red (LF)			2		
Dzalpach Composite					
Sierra Red	5	5	12	5	
Laguna Verde Incised			2		
Laguan Verde v. resist					
Ciego Composite					
Lagartos Punctate					1
Alta Mira Fluted					
Repasto Black on Red					
Flor Cream					
Mateo Red on Cream					
Polvero Black			1		
Lechugal Incised					
Saban Unslipped					1
Yaxcaba Striated					4
Xanaba Red					11
Caucel Trickel on Red					
Tituc Orange Polychrome v. Tituc					3
Huachinango Bichrome Incised					
Balanza Black					1
Lucha Incised					
Aguila Orange					2
Dos Arroyos Orange Polychrome					5
Caldero Buff Polychrome					
Cetelac Fiber Tempered					
Elote Impressed					
Yalchak Striated					

Table 9. Ceramics from San Lorenzo

<u>Type</u>	3/5/1	3/6/1	3/7/1	4/2&3/1	4/3/2
Maxcanu Buff					
Hunabchen Red					
Kanachen Black					
Tituc Orange Polychrome v. Tituc					
Tituc Orange Polychrome v. Bandas					
Dos Caras Striated				5	
Sacalaca Striated					
Encanto Striated v. Sacna					
Arena Red				7	
Batres Red					
Lakin Impressed					
Muna Slate (LC)					
Sacalum Black on Slate (LC)				1	
Saxche Orange Polychrome				2	1
Juleki Cream Polychrome					
Chantori Black on Orange					
Sayan Red on Cream					
Chum Unslipped					
Yokat Striated		1		237	8
Oxkutzcab Applique					
Muna Slate				102	8
Sacalum Black on Slate				2	2
Tekit Incised					
Tekit Incised v. Dzib					
Akil Impressed				1	
Teabo Red				10	
Becal Incised					
Ticul Thin Slate				7	1
Tabi Gouged-Incised				1	
Dzitas Slate					
Balantun Black on Slate					
Chacmay Incised					
Piste Striated					
Tohil Group					
Navula Unslipped					
Yacman Striated					
Chen Mul Modeled					
Mama Red					
Unidentified	12	3	14	354	12
Total sherds	18	12	33	766	32

Table 9. Ceramics from San Lorenzo

Type	4/4/1	4/5/1	4/6/1	4/7/1	4/8/1
Achiotes Unslipped					
Yotolin Patterned Burnished	1				
Chunhinta Black v. Ucu	3				
Nacolal Incised					
Dzocobel Red on Black					
Uchben Incised dichrome					
Joventud Red	1				
Desvario Chamfered			1		
Guitarra Incised					
Dzudzuquil Cream to Buff	1	13	3		
Tumben Incised				1	
Petjal Red on Black and Cream					
Majan Red on Cream					
Canaima Incised dichrome					
Loche Incised dichrome					
Tipikal Red on Striated					
Unto Preslipped Striated Black					
Chancenote Unslipped	3	12	7	2	
Tancah Unslipped					
Xanaba Red (LF)					3
Dzalpach Composite					
Sierra Red	27	52	68	1	
Laguna Verde Incised	1	3			
Laguan Verde v. resist					
Ciego Composite					
Lagartos Punctate	2	1	1		
Alta Mira Fluted					
Repasto Black on Red		1	1		
Flor Cream					
Mateo Red on Cream					
Polvero Black					
Lechugal Incised					
Saban Unslipped	1				
Yaxcaba Striated	11		11		
Xanaba Red	10	10	35		
Caucel Trickel on Red			4		
Tituc Orange Polychrome v. Tituc	1				
Huachinango Bichrome Incised					
Balanza Black	1		2		
Lucha Incised					
Aguila Orange	1				
Dos Arroyos Orange Polychrome					
Caldero Buff Polychrome					
Cetelac Fiber Tempered					
Elote Impressed			1		
Yalchak Striated					

Table 9. Ceramics from San Lorenzo

<u>Type</u>	4/4/1	4/5/1	4/6/1	4/7/1	4/8/1
Maxcanu Buff					
Hunabchen Red					
Kanachen Black					
Tituc Orange Polychrome v. Tituc					
Tituc Orange Polychrome v. Bandas					
Dos Caras Striated					
Sacalaca Striated					
Encanto Striated v. Sacna					
Arena Red					
Batres Red					
Lakin Impressed					
Muna Slate (LC)					
Sacalum Black on Slate (LC)					
Saxche Orange Polychrome					
Juleki Cream Polychrome					
Chantori Black on Orange					
Sayan Red on Cream					
Chum Unslipped					
Yokat Striated	29				
Oxkutzcab Applique					
Muna Slate	14				
Sacalum Black on Slate	2				
Tekit Incised	1				
Tekit Incised v. Dzib					
Akil Impressed					
Teabo Red					
Becal Incised					
Ticul Thin Slate	2				
Tabi Gouged-Incised					
Dzitas Slate					
Balantun Black on Slate					
Chacmay Incised					
Piste Striated					
Tohil Group					
Navula Unslipped					
Yacman Striated					
Chen Mul Modeled					
Mama Red					
Unidentified	111	103	80	7	
Total sherds	223	195	214	11	3

Table 9. Ceramics from San Lorenzo

<u>Type</u>	4/8/2	5/1/1	5/2/1	5/3/1	5/3/2
Achiotes Unslipped	18				
Yotolin Patterned Burnished					
Chunhinta Black v. Ucu	14				1
Nacolal Incised	3				
Dzocobel Red on Black					
Uchben Incised dichrome	3				
Joventud Red	1				
Desvario Chamfered					
Guitarra Incised	1				
Dzudzuquil Cream to Buff	125				
Tumben Incised	44				1
Petjal Red on Black and Cream	1				
Majan Red on Cream					
Canaima Incised dichrome	7				
Loche Incised dichrome					
Tipikal Red on Striated					
Unto Preslipped Striated Black					
Chancenote Unslipped	59				1
Tancah Unslipped					
Xanaba Red (LF)					
Dzalpach Composite					
Sierra Red	51			2	9
Laguna Verde Incised	9				1
Laguan Verde v. resist					
Ciego Composite					
Lagartos Punctate					
Alta Mira Fluted					
Repasto Black on Red					
Flor Cream					
Mateo Red on Cream					
Polvero Black	2				
Lechugal Incised					
Saban Unslipped					
Yaxcaba Striated					
Xanaba Red				1	3
Caucel Trickel on Red					
Tituc Orange Polychrome v. Tituc					
Huachinango Bichrome Incised					
Balanza Black					1
Lucha Incised					1
Aguila Orange					
Dos Arroyos Orange Polychrome					
Caldero Buff Polychrome					
Cetelac Fiber Tempered					
Elote Impressed					
Yalchak Striated					

Table 9. Ceramics from San Lorenzo

<u>Type</u>	4/8/2	5/1/1	5/2/1	5/3/1	5/3/2
Maxcanu Buff					
Hunabchen Red					
Kanachen Black					
Tituc Orange Polychrome v. Tituc					
Tituc Orange Polychrome v. Bandas					
Dos Caras Striated					
Sacalaca Striated					
Encanto Striated v. Sacna					
Arena Red					
Batres Red					
Lakin Impressed					
Muna Slate (LC)					
Sacalum Black on Slate (LC)					
Saxche Orange Polychrome					
Juleki Cream Polychrome					
Chantori Black on Orange					
Sayan Red on Cream					
Chum Unslipped					
Yokat Striated		39	15		17
Oxkutzcab Applique					
Muna Slate		20	4		4
Sacalum Black on Slate					
Tekit Incised					
Tekit Incised v. Dzib					
Akil Impressed					
Teabo Red		3	2		
Becal Incised					
Ticul Thin Slate					1
Tabi Gouged-Incised					
Dzitas Slate					
Balantun Black on Slate					
Chacmay Incised					
Piste Striated					
Tohil Group					
Navula Unslipped					
Yacman Striated					
Chen Mul Modeled					
Mama Red					
Unidentified	278	51	24	2	30
Total sherds	616	113	46	4	70

Table 9. Ceramics from San Lorenzo

<u>Type</u>	Total
Achiotes Unslipped	22
Yotolin Patterned Burnished	1
Chunhinta Black v. Ucu	25
Nacolal Incised	7
Dzocobel Red on Black	0
Uchben Incised dichrome	3
Joventud Red	2
Desvario Chamfered	1
Guitarra Incised	1
Dzudzuquil Cream to Buff	176
Tumben Incised	55
Petjal Red on Black and Cream	1
Majan Red on Cream	0
Canaima Incised dichrome	11
Loche Incised dichrome	1
Tipikal Red on Striated	0
Unto Preslipped Striated Black	0
Chancenote Unslipped	91
Tancah Unslipped	0
Xanaba Red (LF)	7
Dzalpach Composite	0
Sierra Red	259
Laguna Verde Incised	24
Laguan Verde v. resist	1
Ciego Composite	1
Lagartos Punctate	5
Alta Mira Fluted	0
Repasto Black on Red	2
Flor Cream	1
Mateo Red on Cream	0
Polvero Black	14
Lechugal Incised	0
Saban Unslipped	3
Yaxcaba Striated	27
Xanaba Red	72
Caucel Trickle on Red	5
Tituc Orange Polychrome v. Tituc	4
Huachinango Bichrome Incised	0
Balanza Black	14
Lucha Incised	1
Aguila Orange	3
Dos Arroyos Orange Polychrome	11
Caldero Buff Polychrome	0
Cetelac Fiber Tempered	0
Elote Impressed	1
Yalchak Striated	0

Table 9. Ceramics from San Lorenzo

<u>Type</u>	Total
Maxcanu Buff	0
Hunabchen Red	0
Kanachen Black	0
Tituc Orange Polychrome v. Tituc	0
Tituc Orange Polychrome v. Bandas	0
Dos Caras Striated	7
Sacalaca Striated	0
Encanto Striated v. Sacna	0
Arena Red	7
Batres Red	0
Lakin Impressed	0
Muna Slate (LC)	0
Sacalum Black on Slate (LC)	1
Saxche Orange Polychrome	3
Juleki Cream Polychrome	0
Chantori Black on Orange	0
Sayan Red on Cream	0
Chum Unslipped	0
Yokat Striated	459
Oxkutzcab Applique	0
Muna Slate	214
Sacalum Black on Slate	8
Tekit Incised	3
Tekit Incised v. Dzib	0
Akil Impressed	4
Teabo Red	24
Becal Incised	0
Ticul Thin Slate	13
Tabi Gouged-Incised	2
Dzitas Slate	0
Balantun Black on Slate	1
Chacmay Incised	0
Piste Striated	0
Tohil Group	0
Navula Unslipped	0
Yacman Striated	1
Chen Mul Modeled	11
Mama Red	0
Unidentified	1448
Total sherds	3058

Table 10. Ceramics from Santa Cruz

<u>Type</u>	Sup (Op/Lev/Lot)
Achiotes Unslipped	
Chunhintá Black v. Ucu	
Nacolal Incised	
Dzocobel Red on Black	
Joventud Red	
Desvario Chamfered	
Guitarra Incised	
Dzudzuquil Cream to Buff	
Tumben Incised	
Majan Red on Cream	
Tipikal Red on Striated	
Unto Preslipped Striated Black	
Chancenote Unslipped	
Tancah Unslipped	
Xanaba Red (LF)	
Dzalpach Composite	
Sierra Red	1
Laguna Verde Incised	
Ciego Composite	
Lagartos Punctate	
Alta Mira Fluted	
Repasto Black on Red	
Flor Cream	
Mateo Red on Cream	
Polvero Black	
Saban Unslipped	
Yaxcaba Striated	
Xanaba Red	
Caucel Trickel on Red	
Tituc Orange Polychrome v. Tituc	
Huachinango Bichrome Incised	
Balanza Black	
Lucha Incised	
Aguila Orange	
Dos Arroyos Orange Polychrome	
Caldero Buff Polychrome	
Cetelac Fiber Tempered	
Elote Impressed	
Yalchak Striated	
Maxcanu Buff	

Table 10. Ceramics from Santa Cruz

<u>Type</u>	Sup (Op/Lev/Lot)
Hunabchen Red	
Kanachen Black	
Tituc Orange Polychrome v. Tituc	
Tituc Orange Polychrome v. Bandas	
Dos Caras Striated	
Sacalaca Striated	
Encanto Striated v. Sacna	
Arena Red	
Batres Red	
Lakin Impressed	
Muna Slate (LC)	
Sacalum Black on Slate (LC)	
Saxche Orange Polychrome	
Juleki Cream Polychrome	
Chantori Black on Orange	
Sayan Red on Cream	
Chum Unslipped	
Yokat Striated	1
Oxkutzcab Applique	
Muna Slate	1
Sacalum Black on Slate	1
Tekit Incised	
Tekit Incised v. Dzib	
Akil Impressed	
Teabo Red	
Becal Incised	
Ticul Thin Slate	
Tabi Gougged-Incised	
Dzitas Slate	
Balantun Black on Slate	
Chacmay Incised	
Piste Striated	
Tohil Group	
Navula Unslipped	
Yacman Striated	
Chen Mul Modeled	
Mama Red	
Unidentified	
Total sherds	4

Table 11. Ceramic from Sisal

<u>Type</u>	2/1/1 (Op/Lev/Lot)	2/2/1	2/3/1	2/4/1	2/5/1
Achiotes Unslipped					
Chunhinta Black v. Ucu					
Nacolal Incised					
Dzocobel Red on Black					
Joventud Red					
Desvario Chamfered					
Guitarra Incised					
Dzudzuquil Cream to Buff					
Tumben Incised					
Majan Red on Cream					
Tipikal Red on Striated					
Unto Preslipped Striated Black					
Chancenote Unslipped					
Tancah Unslipped					
Xanaba Red (LF)					
Dzalpach Composite					
Sierra Red					
Laguna Verde Incised					
Ciego Composite					
Lagartos Punctate					
Alta Mira Fluted					
Repasto Black on Red					
Flor Cream					
Mateo Red on Cream					
Polvero Black					
Saban Unslipped					
Yaxcaba Striated					
Xanaba Red					
Caucel Trickel on Red					
Tituc Orange Polychrome v. Tituc					
Huachinango Bichrome Incised					
Balanza Black					
Lucha Incised					
Aguila Orange					
Dos Arroyos Orange Polychrome					
Caldero Buff Polychrome					
Cetelac Fiber Tempered					
Elote Impressed					
Yalchak Striated					

Table 11. Ceramic from Sisal

<u>Type</u>	2/1/1 (Op/Lev/Lot)	2/2/1	2/3/1	2/4/1	2/5/1
Maxcanu Buff					
Hunabchen Red					
Kanachen Black					
Tituc Orange Polychrome v. Tituc					
Tituc Orange Polychrome v. Bandas					
Dos Caras Striated					
Sacalaca Striated					
Encanto Striated v. Sacna					
Arena Red					
Batres Red					
Lakin Impressed					
Muna Slate (LC)					
Sacalum Black on Slate (LC)					
Saxche Orange Polychrome					
Juleki Cream Polychrome					
Chantori Black on Orange					
Sayan Red on Cream					
Tunich Red on Orange					
Chum Unslipped					
Yokat Striated					
Oxkutzcab Applique					
Muna Slate				1	
Sacalum Black on Slate					
Tekit Incised					
Tekit Incised v. Dzib					
Akil Impressed					
Teabo Red					1
Becal Incised					
Ticul Thin Slate					1
Tabi Gouged-Incised					
Dzitas Slate					
Balantun Black on Slate					
Chacmay Incised					
Piste Striated					
Tohil Group					
Navula Unslipped					
Yacman Striated					
Chen Mul Modeled					
Mama Red					
Unidentified	6		1	3	18
Total sherds	6	0	2	5	18

Table 11. Ceramic from Sisal

Type	2/6/1	3/1/1	3/1/2	3/2/1	3/3/1
Achiotas Unslipped					
Chunhinta Black v. Ucu					
Nacolal Incised					
Dzocobel Red on Black					
Joventud Red					
Desvario Chamfered					
Guitarra Incised					
Dzudzuquil Cream to Buff					
Tumben Incised					1
Majan Red on Cream					
Tipikal Red on Striated					
Unto Preslipped Striated Black					
Chancenote Unslipped					
Tancah Unslipped					
Xanaba Red (LF)					
Dzalpach Composite					
Sierra Red					
Laguna Verde Incised					
Ciego Composite					
Lagartos Punctate					
Alta Mira Fluted					
Repasto Black on Red					
Flor Cream					
Mateo Red on Cream					
Polvero Black					
Saban Unslipped					
Yaxcaba Striated			1		2
Xanaba Red	1		4	1	
Caucel Trickle on Red			1		1
Tituc Orange Polychrome v. Tituc					
Huachinango Bichrome Incised					
Balanza Black					
Lucha Incised					
Aguila Orange					1
Dos Arroyos Orange Polychrome			1	1	
Caldero Buff Polychrome					
Cetelac Fiber Tempered					
Elote Impressed					
Yalchak Striated					

Table 11. Ceramic from Sisal

<u>Type</u>	2/6/1	3/1/1	3/1/2	3/2/1	3/3/1
Maxcanu Buff					
Hunabchen Red					
Kanachen Black					
Tituc Orange Polychrome v. Tituc					
Tituc Orange Polychrome v. Bandas					
Dos Caras Striated					1
Sacalaca Striated					
Encanto Striated v. Sacna					
Arena Red					
Batres Red					
Lakin Impressed					
Muna Slate (LC)				1	
Sacalum Black on Slate (LC)					
Saxche Orange Polychrome					
Juleki Cream Polychrome					
Chantori Black on Orange					
Sayan Red on Cream					
Tunich Red on Orange					
Chum Unslipped				1	
Yokat Striated	1	32		62	
Oxkutzcab Applique					
Muna Slate	1	28		49	1
Sacalum Black on Slate		2		5	
Tekit Incised		4		6	
Tekit Incised v. Dzib					
Akil Impressed					
Teabo Red					
Becal Incised					
Ticul Thin Slate	1	1			
Tabi Gougged-Incised					
Dzitas Slate					
Balantun Black on Slate					
Chacmay Incised					
Piste Striated					
Tohil Group					
Navula Unslipped		2			
Yacman Striated			2	4	
Chen Mul Modeled		25	1	33	
Mama Red					
Unidentified	9	22	2	51	2
Total sherds	13	116	12	214	9

Table 11. Ceramic from Sisal

Type	3/4/1	3/6/1	3/8/1	3/9/1	3/10/1
Achiotas Unslipped					
Chunhinta Black v. Ucu					
Nacolal Incised					
Dzocobel Red on Black					
Joventud Red					
Desvario Chamfered					
Guitarra Incised					
Dzudzuquil Cream to Buff	1				
Tumben Incised			1		
Majan Red on Cream					
Tipikal Red on Striated					
Unto Preslipped Striated Black					
Chancenote Unslipped			1		
Tancah Unslipped	1				
Xanaba Red (LF)					
Dzalpach Composite					
Sierra Red	3		1		
Laguna Verde Incised					
Ciego Composite					
Lagartos Punctate					
Alta Mira Fluted					
Repasto Black on Red					
Flor Cream					
Mateo Red on Cream					
Polvero Black			1		
Saban Unslipped	2				
Yaxcaba Striated	11	9	3	2	2
Xanaba Red	19	8	6		1
Caucel Trickle on Red	14	2	1		
Tituc Orange Polychrome v. Tituc					
Huachinango Bichrome Incised					
Balanza Black	1				
Lucha Incised					
Aguila Orange	1				1
Dos Arroyos Orange Polychrome		1			
Caldero Buff Polychrome					
Cetelac Fiber Tempered					
Elote Impressed	2				
Yalchak Striated					

Table 11. Ceramic from Sisal

<u>Type</u>	3/4/1	3/6/1	3/8/1	3/9/1	3/10/1
Maxcanu Buff	2				
Hunabchen Red					
Kanachen Black					
Tituc Orange Polychrome v. Tituc					
Tituc Orange Polychrome v. Bandas					
Dos Caras Striated					
Sacalaca Striated					
Encanto Striated v. Sacna					
Arena Red					
Batres Red					
Lakin Impressed					
Muna Slate (LC)					
Sacalum Black on Slate (LC)					
Saxche Orange Polychrome					
Juleki Cream Polychrome					
Chantori Black on Orange					
Sayan Red on Cream					
Tunich Red on Orange					
Chum Unslipped					
Yokat Striated					
Oxkutzcab Applique					
Muna Slate	1				
Sacalum Black on Slate					
Tekit Incised					
Tekit Incised v. Dzib					
Akil Impressed					
Teabo Red					
Becal Incised					
Ticul Thin Slate					
Tabi Gougged-Incised					
Dzitas Slate					
Balantun Black on Slate					
Chacmay Incised					
Piste Striated					
Tohil Group					
Navula Unslipped					
Yacman Striated					
Chen Mul Modeled					
Mama Red					
Unidentified	20	1	9		
Total sherds	78	21	23	2	4

Table 11. Ceramic from Sisal

Type	3/12/1	3/13/1	3/15/1	4/1/1	4/2/1
Achiotas Unslipped					
Chunhinta Black v. Ucu					
Nacolal Incised					
Dzocobel Red on Black					
Joventud Red					
Desvario Chamfered					
Guitarra Incised					
Dzudzuquil Cream to Buff					
Tumben Incised					
Majan Red on Cream					
Tipikal Red on Striated					
Unto Preslipped Striated Black					
Chancenote Unslipped		1			
Tancah Unslipped					
Xanaba Red (LF)					
Dzalpach Composite					
Sierra Red		8	5	2	3
Laguna Verde Incised			1		
Ciego Composite					
Lagartos Punctate					
Alta Mira Fluted					
Repasto Black on Red					
Flor Cream					
Mateo Red on Cream					
Polvero Black					
Saban Unslipped					
Yaxcaba Striated	1	1			
Xanaba Red	5	3	4	7	8
Caucel Trickle on Red					
Tituc Orange Polychrome v. Tituc					
Huachinango Bichrome Incised					
Balanza Black					
Lucha Incised					
Aguila Orange		1			
Dos Arroyos Orange Polychrome				2	
Caldero Buff Polychrome					
Cetelac Fiber Tempered					
Elote Impressed		2			
Yalchak Striated					

Table 11. Ceramic from Sisal

<u>Type</u>	3/12/1	3/13/1	3/15/1	4/1/1	4/2/1
Maxcanu Buff					
Hunabchen Red					
Kanachen Black					
Tituc Orange Polychrome v. Tituc					
Tituc Orange Polychrome v. Bandas					
Dos Caras Striated				4	5
Sacalaca Striated				12	
Encanto Striated v. Sacna				2	
Arena Red				3	13
Batres Red					
Lakin Impressed					
Muna Slate (LC)				1	5
Sacalum Black on Slate (LC)					
Saxche Orange Polychrome					
Juleki Cream Polychrome					
Chantori Black on Orange					
Sayan Red on Cream					
Tunich Red on Orange					
Chum Unslipped					
Yokat Striated			2	185	134
Oxkutzcab Applique					
Muna Slate			2	86	42
Sacalum Black on Slate				6	3
Tekit Incised				1	1
Tekit Incised v. Dzib					
Akil Impressed					
Teabo Red				9	5
Becal Incised					
Ticul Thin Slate				1	
Tabi Gougged-Incised					
Dzitas Slate					
Balantun Black on Slate					
Chacmay Incised					
Piste Striated					
Tohil Group					
Navula Unslipped				2	
Yacman Striated				1	
Chen Mul Modeled				4	
Mama Red					
Unidentified		7	10	303	152
Total sherds	6	23	24	631	371

Table 11. Ceramic from Sisal

Type	4/3/1	4/4/1	5/1/1	5/2/1	5/3/1
Achiotes Unslipped					
Chunhinta Black v. Ucu		1			
Nacolal Incised					
Dzocobel Red on Black					
Joventud Red					
Desvario Chamfered					
Guitarra Incised					
Dzudzuquil Cream to Buff					
Tumben Incised					
Majan Red on Cream					
Tipikal Red on Striated					
Unto Preslipped Striated Black					
Chancenote Unslipped	3	2			
Tancah Unslipped					
Xanaba Red (LF)					
Dzalpach Composite					
Sierra Red	23	9	1	1	
Laguna Verde Incised					
Ciego Composite					
Lagartos Punctate					
Alta Mira Fluted					
Repasto Black on Red					
Flor Cream					
Mateo Red on Cream					
Polvero Black		1			
Saban Unslipped					
Yaxcaba Striated					
Xanaba Red	1				
Caucel Trickle on Red					
Tituc Orange Polychrome v. Tituc					
Huachinango Bichrome Incised					
Balanza Black	1				
Lucha Incised					
Aguila Orange					
Dos Arroyos Orange Polychrome		2			
Caldero Buff Polychrome					
Cetelac Fiber Tempered					
Elote Impressed					
Yalchak Striated					

Table 11. Ceramic from Sisal

<u>Type</u>	4/3/1	4/4/1	5/1/1	5/2/1	5/3/1
Maxcanu Buff					
Hunabchen Red					
Kanachen Black					
Tituc Orange Polychrome v. Tituc					
Tituc Orange Polychrome v. Bandas					
Dos Caras Striated					
Sacalaca Striated					
Encanto Striated v. Sacna				1	
Arena Red	2				
Batres Red					
Lakin Impressed					
Muna Slate (LC)			1		
Sacalum Black on Slate (LC)					
Saxche Orange Polychrome					
Juleki Cream Polychrome					
Chantori Black on Orange					
Sayan Red on Cream					
Tunich Red on Orange					
Chum Unslipped					
Yokat Striated	59	15	2	3	6
Oxkutzcab Applique					
Muna Slate	10		1	2	1
Sacalum Black on Slate					
Tekit Incised					
Tekit Incised v. Dzib					
Akil Impressed					
Teabo Red	1				1
Becal Incised				1	
Ticul Thin Slate					
Tabi Gougged-Incised					
Dzitas Slate					
Balantun Black on Slate					
Chacmay Incised					
Piste Striated					
Tohil Group					
Navula Unslipped					
Yacman Striated					
Chen Mul Modeled					
Mama Red					
Unidentified	77	13	6	8	11
Total sherds	177	43	11	16	19

Table 11. Ceramic from Sisal

<u>Type</u>	5/4/1	5/5/1	5/6/1	5/6/2	5/7/1
Achiotas Unslipped					
Chunhinta Black v. Ucu					
Nacolal Incised					
Dzocobel Red on Black					
Joventud Red					
Desvario Chamfered					
Guitarra Incised					
Dzudzuquil Cream to Buff					
Tumben Incised					
Majan Red on Cream					
Tipikal Red on Striated					
Unto Preslipped Striated Black					
Chancenote Unslipped					
Tancah Unslipped					
Xanaba Red (LF)					
Dzalpach Composite					
Sierra Red					
Laguna Verde Incised					
Ciego Composite					
Lagartos Punctate					
Alta Mira Fluted					
Repasto Black on Red					
Flor Cream					
Mateo Red on Cream					
Polvero Black					
Saban Unslipped					
Yaxcaba Striated			1	1	
Xanaba Red					
Caucel Trickle on Red					
Tituc Orange Polychrome v. Tituc					
Huachinango Bichrome Incised					
Balanza Black					
Lucha Incised					
Aguila Orange					
Dos Arroyos Orange Polychrome		1			
Caldero Buff Polychrome					
Cetelac Fiber Tempered					
Elote Impressed					
Yalchak Striated					

Table 11. Ceramic from Sisal

<u>Type</u>	5/4/1	5/5/1	5/6/1	5/6/2	5/7/1
Maxcanu Buff					
Hunabchen Red					
Kanachen Black					
Tituc Orange Polychrome v. Tituc					
Tituc Orange Polychrome v. Bandas					
Dos Caras Striated			1		
Sacalaca Striated					
Encanto Striated v. Sacna					
Arena Red					
Batres Red					
Lakin Impressed					
Muna Slate (LC)					
Sacalum Black on Slate (LC)					
Saxche Orange Polychrome			1		
Juleki Cream Polychrome					
Chantori Black on Orange					
Sayan Red on Cream					
Tunich Red on Orange					
Chum Unslipped					
Yokat Striated	2	2			3
Oxkutzcab Applique					
Muna Slate		2			1
Sacalum Black on Slate					
Tekit Incised					
Tekit Incised v. Dzib					
Akil Impressed					
Teabo Red		1			
Becal Incised					
Ticul Thin Slate					
Tabi Gougged-Incised					
Dzitas Slate					
Balantun Black on Slate					
Chacmay Incised					
Piste Striated					
Tohil Group					
Navula Unslipped					
Yacman Striated					
Chen Mul Modeled					
Mama Red					
Unidentified	1	5	4	5	3
Total sherds	3	11	7	6	7

Table 11. Ceramic from Sisal

Type	5/7/2	5/8/1	5/8/2	6/1/1	6/2/1
Achiotas Unslipped					
Chunhinta Black v. Ucu					
Nacolal Incised					
Dzocobel Red on Black					
Joventud Red					
Desvario Chamfered					
Guitarra Incised					
Dzudzuquil Cream to Buff					
Tumben Incised					
Majan Red on Cream					
Tipikal Red on Striated					
Unto Preslipped Striated Black					
Chancenote Unslipped					
Tancah Unslipped					
Xanaba Red (LF)					
Dzalpach Composite					
Sierra Red					1
Laguna Verde Incised					
Ciego Composite					
Lagartos Punctate					1
Alta Mira Fluted					
Repasto Black on Red					
Flor Cream					
Mateo Red on Cream					
Polvero Black					
Saban Unslipped					
Yaxcaba Striated					
Xanaba Red				2	
Caucel Trickle on Red					2
Tituc Orange Polychrome v. Tituc					
Huachinango Bichrome Incised					
Balanza Black				1	
Lucha Incised					
Aguila Orange					
Dos Arroyos Orange Polychrome		1	1	2	3
Caldero Buff Polychrome					
Cetelac Fiber Tempered					
Elote Impressed					
Yalchak Striated					

Table 11. Ceramic from Sisal

<u>Type</u>	5/7/2	5/8/1	5/8/2	6/1/1	6/2/1
Maxcanu Buff					
Hunabchen Red					
Kanachen Black					
Tituc Orange Polychrome v. Tituc				1	
Tituc Orange Polychrome v. Bandas					
Dos Caras Striated					1
Sacalaca Striated					
Encanto Striated v. Sacna					2
Arena Red					
Batres Red					
Lakin Impressed					
Muna Slate (LC)					
Sacalum Black on Slate (LC)					
Saxche Orange Polychrome					
Juleki Cream Polychrome					
Chantori Black on Orange					
Sayan Red on Cream					
Tunich Red on Orange					
Chum Unslipped					2
Yokat Striated	4	1	6	170	279
Oxkutzcab Applique					
Muna Slate	2	1	8	62	134
Sacalum Black on Slate				2	13
Tekit Incised					
Tekit Incised v. Dzib					
Akil Impressed					
Teabo Red				1	3
Becal Incised					
Ticul Thin Slate				5	8
Tabi Gougged-Incised					
Dzitas Slate					
Balantun Black on Slate					
Chacmay Incised					
Piste Striated					
Tohil Group					
Navula Unslipped				2	
Yacman Striated					
Chen Mul Modeled				1	
Mama Red					
Unidentified	7	0	5	78	88
Total sherds	13	3	20	327	537

Table 11. Ceramic from Sisal

Type	6/3/1	6/4/1	7/1/1	7/3/1	7/4/1
Achiotes Unslipped					
Chunhinta Black v. Ucu		6			
Nacolal Incised					
Dzocobel Red on Black					
Joventud Red					
Desvario Chamfered					
Guitarra Incised					
Dzudzuquil Cream to Buff		1			
Tumben Incised		1			
Majan Red on Cream					
Tipikal Red on Striated					
Unto Preslipped Striated Black					
Chancenote Unslipped	1	6			
Tancah Unslipped					
Xanaba Red (LF)					
Dzalpach Composite					
Sierra Red	1	22			
Laguna Verde Incised		1			
Ciego Composite					
Lagartos Punctate					
Alta Mira Fluted			1		
Repasto Black on Red					
Flor Cream					
Mateo Red on Cream					
Polvero Black					
Saban Unslipped					
Yaxcaba Striated		7			
Xanaba Red	3	26			
Caucel Trickle on Red		7			
Tituc Orange Polychrome v. Tituc		2			
Huachinango Bichrome Incised					
Balanza Black					
Lucha Incised					
Aguila Orange		5			
Dos Arroyos Orange Polychrome		10			
Caldero Buff Polychrome					
Cetelac Fiber Tempered					
Elote Impressed					
Yalchak Striated					

Table 11. Ceramic from Sisal

<u>Type</u>	6/3/1	6/4/1	7/1/1	7/3/1	7/4/1
Maxcanu Buff					
Hunabchen Red					
Kanachen Black					
Tituc Orange Polychrome v. Tituc					
Tituc Orange Polychrome v. Bandas					
Dos Caras Striated					
Sacalaca Striated					
Encanto Striated v. Sacna					
Arena Red	1				
Batres Red		1			
Lakin Impressed					
Muna Slate (LC)					
Sacalum Black on Slate (LC)					
Saxche Orange Polychrome	1	1			
Juleki Cream Polychrome					
Chantori Black on Orange					
Sayan Red on Cream					
Tunich Red on Orange		3			
Chum Unslipped					
Yokat Striated	39	95	20	12	2
Oxkutzcab Applique					
Muna Slate	16	22	8	2	1
Sacalum Black on Slate	2	8			
Tekit Incised					
Tekit Incised v. Dzib					
Akil Impressed					
Teabo Red	1	1			
Becal Incised					
Ticul Thin Slate		3			
Tabi Gougged-Incised					
Dzitas Slate					
Balantun Black on Slate					
Chacmay Incised					
Piste Striated					
Tohil Group					
Navula Unslipped					
Yacman Striated		1			
Chen Mul Modeled	1	7			
Mama Red		1			
Unidentified	25	116	23	10	2
Total sherds	91	354	51	24	5

Table 11. Ceramic from Sisal

Type	7/5/1	7/5/2	7/6/2	7/7/1	7/8/1
Achiotas Unslipped					
Chunhinta Black v. Ucu					
Nacolal Incised					
Dzocobel Red on Black					
Joventud Red					
Desvario Chamfered					
Guitarra Incised					
Dzudzuquil Cream to Buff					1
Tumben Incised					
Majan Red on Cream					
Tipikal Red on Striated					
Unto Preslipped Striated Black					
Chancenote Unslipped					1
Tancah Unslipped					
Xanaba Red (LF)					
Dzalpach Composite					
Sierra Red	1				
Laguna Verde Incised					
Ciego Composite					
Lagartos Punctate					
Alta Mira Fluted					
Repasto Black on Red					
Flor Cream					
Mateo Red on Cream					
Polvero Black					
Saban Unslipped					
Yaxcaba Striated	4	3		1	1
Xanaba Red		2	1		1
Caucel Trickle on Red					
Tituc Orange Polychrome v. Tituc					
Huachinango Bichrome Incised					
Balanza Black					
Lucha Incised					
Aguila Orange					1
Dos Arroyos Orange Polychrome		2			
Caldero Buff Polychrome				1	
Cetelac Fiber Tempered					
Elote Impressed					
Yalchak Striated					

Table 11. Ceramic from Sisal

<u>Type</u>	7/5/1	7/5/2	7/6/2	7/7/1	7/8/1
Maxcanu Buff					
Hunabchen Red					
Kanachen Black					
Tituc Orange Polychrome v. Tituc					
Tituc Orange Polychrome v. Bandas					
Dos Caras Striated					
Sacalaca Striated					
Encanto Striated v. Sacna					
Arena Red					
Batres Red					
Lakin Impressed					
Muna Slate (LC)					
Sacalum Black on Slate (LC)					
Saxche Orange Polychrome					
Juleki Cream Polychrome					
Chantori Black on Orange					
Sayan Red on Cream					
Tunich Red on Orange					
Chum Unslipped					
Yokat Striated		7			
Oxkutzcab Applique					
Muna Slate		2			
Sacalum Black on Slate					
Tekit Incised					
Tekit Incised v. Dzib					
Akil Impressed					
Teabo Red					
Becal Incised					
Ticul Thin Slate					
Tabi Gougged-Incised					
Dzitas Slate					
Balantun Black on Slate					
Chacmay Incised					
Piste Striated					
Tohil Group					
Navula Unslipped					
Yacman Striated					
Chen Mul Modeled					
Mama Red					
Unidentified		4	1	5	3
Total sherds	5	20	2	7	8

Table 11. Ceramic from Sisal

Type	7/9/1	7/10/1	7/11/1	7/11/2	Total
Achiotas Unslipped					0
Chunhinta Black v. Ucu				1	8
Nacolal Incised				1	1
Dzocobel Red on Black					0
Joventud Red					0
Desvario Chamfered					0
Guitarra Incised					0
Dzudzuquil Cream to Buff				3	6
Tumben Incised					3
Majan Red on Cream					0
Tipikal Red on Striated					0
Unto Preslipped Striated Black					0
Chancenote Unslipped					15
Tancah Unslipped					1
Xanaba Red (LF)			1		1
Dzalpach Composite					0
Sierra Red		3	4	2	90
Laguna Verde Incised			1	2	5
Ciego Composite		2			2
Lagartos Punctate					1
Alta Mira Fluted					1
Repasto Black on Red					0
Flor Cream					0
Mateo Red on Cream					0
Polvero Black			1		3
Saban Unslipped					2
Yaxcaba Striated					50
Xanaba Red		2		2	107
Caucel Trickle on Red		1			29
Tituc Orange Polychrome v. Tituc					2
Huachinango Bichrome Incised					0
Balanza Black					3
Lucha Incised					0
Aguila Orange					10
Dos Arroyos Orange Polychrome					27
Caldero Buff Polychrome					1
Cetelac Fiber Tempered					0
Elote Impressed				1	5
Yalchak Striated					0

Table 11. Ceramic from Sisal

<u>Type</u>	7/9/1	7/10/1	7/11/1	7/11/2	Total
Maxcanu Buff					2
Hunabchen Red					0
Kanachen Black					0
Tituc Orange Polychrome v. Tituc					1
Tituc Orange Polychrome v. Bandas					0
Dos Caras Striated					12
Sacalaca Striated					12
Encanto Striated v. Sacna					5
Arena Red					19
Batres Red					1
Lakin Impressed					0
Muna Slate (LC)					8
Sacalum Black on Slate (LC)					0
Saxche Orange Polychrome					3
Juleki Cream Polychrome					0
Chantori Black on Orange					0
Sayan Red on Cream					0
Tunich Red on Orange					3
Chum Unslipped					3
Yokat Striated					1143
Oxkutzcab Applique					0
Muna Slate	1		2		489
Sacalum Black on Slate					41
Tekit Incised					12
Tekit Incised v. Dzib					0
Akil Impressed					0
Teabo Red	2		2		28
Becal Incised					1
Ticul Thin Slate					20
Tabi Gougged-Incised					0
Dzitas Slate					0
Balantun Black on Slate					0
Chacmay Incised					0
Piste Striated					0
Tohil Group					0
Navula Unslipped					6
Yacman Striated					8
Chen Mul Modeled					72
Mama Red					1
Unidentified	3		3	17	1139
					0
Total sherds	6	8	14	29	3402

Table 12. Ceramics from Xbalcheil

<u>Type</u>	SurfaceA (Op/Lev/Lot)	SurfaceB	SurfaceC
Achiotes Unslipped			
Chunhintá Black v. Ucu			
Nacolal Incised			
Dzocobel Red on Black			
Joventud Red			
Desvario Chamfered			
Guitarra Incised			
Dzudzuquil Cream to Buff			
Tumben Incised			
Majan Red on Cream			
Tipikal Red on Striated			
Unto Preslipped Striated Black			
Chancenote Unslipped		1	
Tancah Unslipped			
Xanaba Red (LF)			
Dzalpach Composite			
Sierra Red		1	
Laguna Verde Incised			
Ciego Composite			
Lagartos Punctate			
Alta Mira Fluted			
Repasto Black on Red			
Flor Cream			
Mateo Red on Cream			
Polvero Black			
Saban Unslipped			
Yaxcaba Striated			
Xanaba Red	1		1
Caucel Trickel on Red			
Tituc Orange Polychrome v. Tituc			
Huachinango Bichrome Incised			
Balanza Black			
Lucha Incised			
Aguila Orange		1	
Dos Arroyos Orange Polychrome			
Caldero Buff Polychrome			
Cetelac Fiber Tempered			
Elote Impressed			
Yalchak Striated			
Maxcanu Buff			

Table 12. Ceramics from Xbalcheil

<u>Type</u>	SurfaceA (Op/Lev/Lot)	SurfaceB	SurfaceC
Hunabchen Red			
Kanachen Black			
Tituc Orange Polychrome v. Tituc			
Tituc Orange Polychrome v. Bandas			
Dos Caras Striated			
Sacalaca Striated			
Encanto Striated v. Sacna			
Arena Red			
Batres Red			
Lakin Impressed			
Muna Slate (LC)			
Sacalum Black on Slate (LC)			
Saxche Orange Polychrome			
Juleki Cream Polychrome			
Chantori Black on Orange			
Sayan Red on Cream			
Chum Unslipped			
Yokat Striated	1	1	1
Oxkutzcab Applique			1
Muna Slate		1	1
Sacalum Black on Slate			1
Tekit Incised			
Tekit Incised v. Dzib			
Akil Impressed			
Teabo Red		1	1
Becal Incised			
Ticul Thin Slate			
Tabi Gouged-Incised			
Dzitas Slate			
Balantun Black on Slate			
Chacmay Incised			
Piste Striated			
Tohil Group			
Navula Unslipped			
Yacman Striated			
Chen Mul Modeled			
Mama Red			
Unidentified			
Total sherds	2	6	6

Table 13. Ceramics from Xtojil

<u>Type</u>	Surface milpa (Op/Lev/Lot)	Surface
Achiotes Unslipped		
Chunhinta Black v. Ucu		
Nacolal Incised		
Dzocobel Red on Black		
Joventud Red		
Desvario Chamfered		
Guitarra Incised		
Dzudzuquil Cream to Buff		
Tumben Incised		
Majan Red on Cream		
Tipikal Red on Striated		
Unto Preslipped Striated Black		
Chancenote Unslipped		
Tancah Unslipped		
Xanaba Red (LF)		
Dzalpach Composite		
Sierra Red	1	
Laguna Verde Incised		
Ciego Composite		
Lagartos Punctate		
Alta Mira Fluted		
Repasto Black on Red		
Flor Cream		
Mateo Red on Cream		
Polvero Black		
Saban Unslipped		
Yaxcaba Striated		
Xanaba Red		
Caucel Trickel on Red		
Tituc Orange Polychrome v. Tituc		
Huachinango Bichrome Incised		
Balanza Black		
Lucha Incised		
Aguila Orange		
Dos Arroyos Orange Polychrome		
Caldero Buff Polychrome		
Cetelac Fiber Tempered		
Elote Impressed		
Yalchak Striated		
Maxcanu Buff		

Table 13. Ceramics from Xtojil

<u>Type</u>	Surface milpa (Op/Lev/Lot)	Surface
Hunabchen Red		
Kanachen Black		
Tituc Orange Polychrome v. Tituc		
Tituc Orange Polychrome v. Bandas		
Dos Caras Striated		
Sacalaca Striated		
Encanto Striated v. Sacna		
Arena Red		
Batres Red		
Lakin Impressed		
Muna Slate (LC)		
Sacalum Black on Slate (LC)		
Saxche Orange Polychrome		
Juleki Cream Polychrome		
Chantori Black on Orange		
Sayan Red on Cream		
Chum Unslipped		
Yokat Striated		1
Oxkutzcab Applique		
Muna Slate	1	1
Sacalum Black on Slate	1	
Tekit Incised		
Tekit Incised v. Dzib		
Akil Impressed		
Teabo Red		
Becal Incised		
Ticul Thin Slate		1
Tabi Gougged-Incised		
Dzitas Slate		
Balantun Black on Slate		
Chacmay Incised		
Piste Striated		
Tohil Group		
Navula Unslipped		
Yacman Striated		
Chen Mul Modeled		
Mama Red		
Unidentified		
Total sherds	3	3

Table 14. Ceramics from Yodzonot

<u>Type</u>	Surface Milpa (Op/Lev/Lot)	Surface Milpa Stav
Achiotes Unslipped		
Chunhintá Black v. Ucu		
Nacolal Incised		
Dzocobel Red on Black		
Joventud Red		
Desvario Chamfered		
Guitarra Incised		
Dzudzuquil Cream to Buff		
Tumben Incised		
Majan Red on Cream		
Tipikal Red on Striated		
Unto Preslipped Striated Black		
Chancenote Unslipped		
Tancah Unslipped		
Xanaba Red (LF)		
Dzalpach Composite		
Sierra Red		
Laguna Verde Incised		
Ciego Composite		
Lagartos Punctate		
Alta Mira Fluted		
Repasto Black on Red		
Flor Cream		
Mateo Red on Cream		
Polvero Black		
Saban Unslipped		
Yaxcaba Striated		
Xanaba Red		
Caucel Trickel on Red		
Tituc Orange Polychrome v. Tituc		
Huachinango Bichrome Incised		
Balanza Black		
Lucha Incised		
Aguila Orange		
Dos Arroyos Orange Polychrome		
Caldero Buff Polychrome		
Cetelac Fiber Tempered		
Elote Impressed		
Yalchak Striated		
Maxcanu Buff		

Table 14. Ceramics from Yodzonot

<u>Type</u>	Surface Milpa (Op/Lev/Lot)	Surface Milpa Stav
Hunabchen Red		
Kanachen Black		
Tituc Orange Polychrome v. Tituc		
Tituc Orange Polychrome v. Bandas		
Dos Caras Striated		
Sacalaca Striated		
Encanto Striated v. Sacna		
Arena Red		
Batres Red		
Lakin Impressed		
Muna Slate (LC)		
Sacalum Black on Slate (LC)		
Saxche Orange Polychrome		
Juleki Cream Polychrome		
Chantori Black on Orange		
Sayan Red on Cream		
Chum Unslipped		
Yokat Striated	3	5
Oxkutzcab Applique		
Muna Slate		8
Sacalum Black on Slate		
Tekit Incised		
Tekit Incised v. Dzib		
Akil Impressed		
Teabo Red		
Becal Incised		
Ticul Thin Slate		
Tabi Gougged-Incised		
Dzitas Slate		
Balantun Black on Slate		
Chacmay Incised		
Piste Striated		
Tohil Group		
Navula Unslipped		
Yacman Striated		
Chen Mul Modeled		
Mama Red		
Unidentified	20	2
Total sherds	23	15

Part 5: Summary and Analysis

Chapter 49: Conclusions

Dave Johnstone

The 2010 field season was divided into mapping and excavation components. The former was intended to address questions of what, and the latter, questions of when. With the mapping, we were looking to clarify spatial some relationships that had been hinted at by earlier field seasons. With the excavation, we were investigating the timing of particular architectural classes or associations. In addition, the collective data would serve as a test against our settlement results from the northern portion of the study area.

Mapping

In all cases this season, mapping was focused on sites that had previously been reported and for which we had GPS points and sketch maps. Of interest was the relationship between the Prehispanic settlement and other cultural or natural features.

One aspect of the mapping, under the direction of Johan Normark, was looking at the relationship between caves and settlement. Xbaquil, Santa Cruz, Xtojil, Yodzont and Aktun Huay Max are sites in the northern portion of the study area that were associated with either *cenotes*, or deep, extensive caves. Gruta de Alux, Actun Abuelos, Chuum Katzin, and Aktun Sac Chikin are sites with smaller caves, located in the southern portion of the study area. In general, there is a positive correlation between the size of the karstic feature and the size of the surrounding settlement. Those caves in the south have only limited settlement, and no large associated architecture, while those in the north are larger in terms of size and of scale. Interestingly, two large karstic features, Aktun Huay Max, and Dzonot San Diego have no surrounding settlement, though there are cultural remains in both. Only Gruta de Alux has seen some excavation, so dating of these occupations is presently unknown. However, Xtojil, Santa Cruz, Xbaquil, and Yodzont contain Terminal Classic occupations on the basis of surface collections and architectural (Puuc style) elements. This might suggest that there was an intensification of settlement around karstic features, particularly the larger ones, during the Terminal Classic period. This might be a response to drier conditions when access to water was a more critical settlement consideration than in other periods. However, this hypothesis does not explain the absence of settlement surrounding some major karstic features. Some, like Yodzont, may have only opened recently. For the others, we must explore other cultural or natural explanations for the absence of settlement.

The second aspect of the mapping program, under the direction of Pablo Huerta and Dave Johnstone, focused on the relationship between prehistoric and historic settlement. The sites of La Esperanza, Xbalcheil, Santa Elena, Xbaquil, San Juan (Sacalaca), Guadalupe, Ramonal Oriente, Rancho San Pablo, San Diego, Palomar, Chuunpich, Yaxche, Fortin de Yo'okop, Rancho Pancho Villa, and Venadito were all mapped as part of this program. All of these sites contained historic components. For

most of the sites, the prehistoric and historic components were closely associated spatially. Some sites, like Yodzonot and Venadito had the two components discretely separated, while others like San Pablo and Pancho Villa had no discernable prehistoric component at all. Within the historic occupations, there are two classes of sites; the ranchos, and the haciendas. The former are smaller, more common, and lack evidence of permanent residence. The latter (Xbaquil, Xbalcheil, Pancho Villa and Palomar) are larger, with more permanent residential structures and often include substantial boundary walls with formal gates. The dating associated with Pancho Villa and the associated architectural similarities between these sites suggest that they are contemporaneous, and pre-date the Caste War. This is not to imply that the ranchos are a later phenomenon, though some, like Venadito, are clearly recent. Instead, these two classes of sites may represent two separate land uses, with the haciendas focusing on raising crops, and the ranchos focused on cattle. It was not apparent based on the architecture, why many sites shared both Pre-Hispanic and Historic components. Limited resources such as water, or fertile soils could be the common factor.

Excavation

With the exception of Parcela Escolar, all of our excavations were carried out in the southern portion of the study area. This was to counter our previous sample which had been heavily weighted to the northern portion of the Coahuah region. Specific features targeted in the 2010 season were wells, ballcourts, rubble construction, and round residences.

The intensification of use of karstic features during the Terminal Classic noted above does not account for the majority of the Terminal Classic sites' water needs. In the Puuc area, the construction of *chultuns* captured pluvial water during the rainy season for later use. These features are infrequent in the Coahuah region, and alone could not have satisfied the occupants' needs for potable water. Shaw and Flores had hypothesized that many of the wells recorded at sites which contained both historic and prehistoric occupations might have been constructed in Prehispanic times. Unfortunately, the excavations within the Sisal well did not reach bedrock. The ceramics recovered were heavily eroded, and had likely washed in from the surface. The absence of historic period artifacts in the sample is not probative, but does lend some weight to the Prehispanic hypothesis. Further excavation of these features will be a priority in coming seasons.

The 2008 field season documented three features tentatively identified as ballcourts in the southern portion of the study area. All were located in small Rank 3 sites without associated monumental architecture. Previous to this, the only ballcourt for the region was located in Yo'okop, one of the Rank 1 sites. Yo'okop's Stela 2 depicts a king playing ball and suggests a Late Classic date for the structure, as well as its important role in kingly display (Johnstone 2008:192-193). We hypothesized that the ballcourts might have been constructed at a later time, possibly during the Postclassic, when centralized authority was largely absent. Two of these new ballcourts, located in Hopemul and Ramonal Quemado, were tested this season. The recovered ceramic lots suggested that these features, and the sites that contained them, dated to the Terminal Classic period. If these features are indeed ballcourts, then their presence in small sites away from centers of political importance represents a break with the previous social or

religious order. Scarborough and Valdez (2009:216) note a similar anomalous ballcourt in the Three Rivers region at a site “not dependent on the truly huge Maya centers developing elsewhere”.

The 2008 field season also documented a number of sites without obvious cut stone for either walls or platform facing. Shaw speculated that they may be late, or special purpose sites, and that any facing may have consisted of non permanent surfaces such as plaster over a dry core hearting. Three of these, Hopemul, Ramonal Quemado, and San Lorenzo were tested this season. With the exception of a few Postclassic sherds at San Lorenzo near structures capped by Postclassic shrines, all of these sites date securely to the Terminal Classic period. Only structural excavation will determine what these structures were originally faced with, however, it is possible that their original stone facings are now covered by collapse. In such a case, it may be that the difference between these and other contemporaneous sites are of degree rather than of kind. Perhaps these sites did not use concrete as a bonding agent and that this contributed to their more advanced state of decay.

The final class of feature tested this season was foundation braces with circular plans. Foundation braces in the Cochuah region are typically rectangular or apsidal in plan, with these forms carrying through from the Late Formative through the Terminal Classic. We had hypothesized that the circular foundations might postdate the earlier forms, and represent the ‘missing’ residences for the Postclassic inhabitants of the region. Test pits near such structures were excavated at the sites of San Lorenzo and Gruta de Alux. While we did identify a few Postclassic sherds in surface lots, they were not sufficiently frequent to assign these features to that period. Instead, the vast majority of the sherds recovered from both sites pertained to the Terminal Classic period. If the round foundation braces do indeed belong in the Terminal Classic, then two other possible hypotheses might be entertained. The first is that the different shape for residences results from its inhabitants having a different architectural tradition. This might result from having immigrants, possibly refugees from the Southern Lowlands. The second is that these structures are not residences, and that they represent a special purpose structure such as a kitchen or granary. While this is a good possibility for most sites with round structures disbursed within the overall settlement, it is made unlikely by the site of Gruta de Alux, where this is the *only* type of foundation brace. It is difficult to imagine an entire site entirely devoted to a single specialized activity.

Settlement

Following the 2008 field season, it was apparent that the northern portion of the study area experienced a construction boom during the Terminal Classic period. Not only did older sites see abundant buildings dating to this time, but that whole new sites were founded as either green field sites, or as reoccupations of sites that had been abandoned. I had speculated (Johnstone 2008:236) that this boom could have resulted from drier conditions that forced some of the population in the southern portion of the study area to abandon sites in that region in favor of locations with better access to the water table. As a result of our dating of many of the sites in the southern portion of the study area, it is now possible to reject that hypothesis. This portion of the study area also displays robust construction within preexisting sites, as well as the founding of new sites, or reoccupation of abandoned ones.

The shift to new sites represents a fundamental change in settlement patterns. Such a change across a region is likely to be a reflection of systemic change rather than of local culture-history. It has profound implications regarding Maya political organization and in their use of resources- particularly water. The spreading of sites across the landscape is a form of population disbursement. In times of drought it is an adaptation that reduces overall uncertainty of crop failure across a region; especially as rainfall can be rather localized. A similar infilling of settlement in the Puuc region has generated speculation (Carmean et al. 2004:440-441) that many of the new smaller settlements represent seasonal farmsteads occupied only during the rainy season. For permanent occupation, there would have to be an investment in alternate means for acquiring or storing water. In this respect, knowing when features such as chultuns and wells were constructed assumes a more central role in understanding how the Maya coped through the dryer parts of the Terminal Classic.

References Cited

Andrews Anthony P.

- 1991 The Rural Chapels and Churches of Early Colonial Yucatán and Belize: An Archaeological Perspective, in *Columbian Consequences*, Vol. 3, ed. by David Hurst Thomas, pp. 355-374, Smithsonian Institution Press, Washington D. C., E. U. A., London.

Awe, Jaime J., Mark D. Campbell, and Jim Conlon

- 1991 Preliminary Analysis of the Spatial Configuration of the Site Core at Cahal Pech, Belize, and Its Implications for Lowland Maya Social Organization. *Mexicon* 13 (2): 25–30.

Barrera Vásquez, Alfredo

- 2001 *Diccionario Maya*, Editorial Porrúa, Ciudad de México, México.

Bracamonte y Sosa, Pedro

- 2001 *La conquista inconclusa de Yucatán. Los mayas de la montaña, 1560-1680*, Colección Peninsular, Miguel Ángel Porrúa librero-editor, CIESAS-Universidad de Quintana Roo, Ciudad de México, México.

Carmean, Kelli, Nicholas Dunning and Jeff Karl Kowalski

- 2004 High Times in the Hill Country: A Perspective from the Terminal Classic Puuc Region. In, *The Terminal Classic in the Maya Lowlands: Collapse, Transition and Transformation*. Ed. by A.A. Demarest, P.M. Rice, and D.S. Rice. University of Press of Colorado, Boulder.

Casares G. Cantón, Raúl E. (dir.)

- 1998 “Guerra de Castas”, in *Yucatán en el tiempo*, enciclopedia alfabética, Inversiones Cares S.A. de C.V., p. 191-195.

Eco, Umberto

- 2005 *La estructura ausente. Introducción a la semiótica*, Editorial Debolsillo, translated from 1968 version, México D.F., pp. 446.

Flores Colin Alberto G.

- 2003 Reconocimiento Arqueológico de Sitios Distantes del Ejido de Sacalaca, in *Reporte Final del Reconocimiento Arqueológico de la Región de Coahuah, Temporada 2003*, ed. by Justine M. Shaw, pp. 63-71, College of the Redwoods, Eureka, CA.

- 2004 Mulob y Pozos: Relaciones entre Asentamientos Prehispánicos y Coloniales, in *Reporte Final del Reconocimiento Arqueológico de la Región de Coahuah, Temporada 2004*, ed. by Justine M. Shaw, pp. 195-208, College of the Redwoods, Eureka, CA.

Flores Colin Alberto G., Dave Johnstone, Justine M. Shaw, Jorge Pablo Huerta Rodríguez and Johan Normark

- 2008 *U chibal be: Un camino de Linaje. El mapeo del Sacbe 2 de Yo'okop*, in *Reporte Final del Reconocimiento Arqueológico de la Región de Cochuah, Temporada 2008*, ed. by Justine M. Shaw, pp. 9-40, College of the Redwoods, Eureka, CA., E. U. A.

Flores Colin, Alberto G. and Jorge Pablo Huerta Rodríguez

- 2008 Chapter 4: Chuunpich. In *The Final Report of the Cochuah Regional Archaeological Survey's 2008 Field Season*, edited by Justine M. Shaw, pp. 37-40. College of the Redwoods, Eureka.

García Preciat

- 1944 *Historia de la Arquitectura*, en *Enciclopedia Yucatanense*, Tomo IV, 409-559, Mérida, Yucatán, México.

Gendrop, Paul

- 1997 *Arquitectura Mesoamericana*, Editorial Trillas, Ciudad de México, México.

- 1983 *Los estilos Río Bes, Chenes y Puuc en la arquitectura maya*. División de estudios de posgrado de la Facultad de Arquitectura, Universidad Nacional Autónoma de México, pp. 243.

Guderjan, Thomas H.

- 2007 *Public Architecture, Ritual, and Temporal Dynamics*, in *The Nature of an Ancient Maya City; Resources, Interaction, and Power at Blue Creek, Belize*, pp. 19- 48, The University of Alabama Press, Tuscaloosa.

Huerta, J. Pablo

- 2008 *Rancho El Palomar*. In, *Final Report of the Cochuah Regional Archaeological Survey's 2008 Field Season*. Ed. by Justine M. Shaw. College of the Redwoods, Eureka.

Johnstone, Dave

- 2008 *Kings Rule! – Not: Changes in Ancient Power and Ideology in the Cochuah Region*. In, *Hierarchy and Power in the History of Civilizations: Ancient and Medieval Cultures* pp. 198-203. Ed. by L.E. Grinin, D.D. Beliaev, and A.V. Korotayev. Russian Academy of Sciences, Moscow.

- 2006 *Final Report of the Cochuah Regional Archeological Survey's 2006 Analysis Season*. College of the Redwoods, Eureka, CA.

- 2005 *Overall Summaries of the 2005 Field Season: Ceramic Summary from the 2005 Cochuah Region Archeological Survey*, In *Final Report of the Cochuah Regional Archaeological Survey's Field Season*, ed. by Justine M. Shaw, pp. 179-227, College of the Redwoods, Eureka, CA.

Kaeding, Adam

- 2005 Xbalche. In, *Final Report of the Coahuah Regional Archaeological Survey's 2005 Field Season*. Ed. by Justine M. Shaw. College of the Redwoods, Eureka.
- 2008a Hacienda Palomar. In, *Final Report of the Coahuah Regional Archaeological Survey's 2008 Field Season*. Ed. by Justine M. Shaw. College of the Redwoods, Eureka.
- 2008b Rancho Pancho Villa. In, *Final Report of the Coahuah Regional Archaeological Survey's 2008 Field Season*. Ed. by Justine M. Shaw. College of the Redwoods, Eureka.
- 2008c Hacienda San Pedro. In, *Final Report of the Coahuah Regional Archaeological Survey's 2008 Field Season*. Ed. by Justine M. Shaw. College of the Redwoods, Eureka.
- 2008d Elementos Históricos No Mapeados, in *Reporte Final del Reconocimiento Arqueológico de la Región de Coahuah, Temporada 2008*, ed. by Justine M. Shaw, pp. 244-246, College of the Redwoods, Eureka, CA., E. U. A.
- 2008e El Fortín de Yo'okop, in *Reporte Final del Reconocimiento Arqueológico de la Región de Coahuah, Temporada 2008*, ed. by Justine M. Shaw, pp. 45-47, College of the Redwoods, Eureka, CA., E. U. A.
- 2008f Hacienda Xbaquil, in *Reporte Final del Reconocimiento Arqueológico de la Región de Coahuah, Temporada 2008*, ed. by Justine M. Shaw, pp. 89-93, College of the Redwoods, Eureka, CA., E. U. A.
- 2008g The Historic Settlement of Parcela Escolar, in *Reporte Final del Reconocimiento Arqueológico de la Región de Coahuah, Temporada 2008*, ed. by Justine M. Shaw, pp. 94-98, College of the Redwoods, Eureka, CA., E. U. A.

Legrand-Girarde and H. Plessix

- 1911 *Manual de fortificación permanente*, Traducida para uso de los alumnos del Colegio Militar por el Coronel de Ingenieros Alberto Canseco. Secretaría de Guerra y Marina Talleres del Departamento de Estado Mayor, pp.502

Lloyd, Christopher

- 2002 Locality and Observations of Group C and Sacbe 2, in *Final Report of Proyecto Arqueológico Yo'okop's 2002 Field Season*, ed. by Justine M. Shaw, pp. 21-27, College of the Redwoods, Eureka, CA., E. U. A.

Mañana, Patricia, Blanco Rebeca, and Ayán Xurxo

2002 *Arquitectura 1: Bases teórico-metodológicas para una Arqueología de la Arquitectura*. Trabajos de Arqueología e Patrimonio, Santiago de Compostela, Laboratorio de Patrimonio, Paleoambiente e Paisaxe, pp. 101.

Martin, Simon

2001 Court and Realm: Architectural Signatures in the Classic Maya Southern Lowlands, in *Royal Courts of the Ancient Maya*, eds. by Takeshi Inomata and Stephen Houston, pp. 168-194, Westview Press, Colorado.

Martos, Luis Alberto

1998 *Reporte de los trabajos de reconocimiento y levantamiento planimétrico, llevados a cabo en Fortín de Yokob, Quintana Roo en febrero de 1998*. Instituto Nacional de Antropología e Historia, D.I.C.P.A.

2010 “Arqueología de la Guerra de Castas en Quintana Roo: el baluarte de Yo’okop y el camino a Chan Santa Cruz”, in *Boletín de Monumentos Históricos*, Tercera Época, Núm. 18, Enero-Abril 2010, INAH, pp. 113-131.

Martos, Luis Alberto and Rodríguez A. Sánchez, Ernesto

1998 *Informe de la temporada 1998 del proyecto de arqueología histórica Fortín de Yokob, Quintana Roo*. Arqlogo. Instituto Nacional de Antropología e Historia, D.I.C.P.A. y D.S.A.

México Militar. Revista Científico-Literaria

1900a “Los soldados federales en la campaña contra los mayas rebeldes” vol.1, núm. 9 1 de octubre de 1900, p. 195

1900b “El Yaqui, Yucatán y el ejército”, vol. 1, núm. 12, 15 de noviembre 1900, p. 246.

1901a “Campaña de Yucatán” vol. 1, núm. 19, 1º marzo 1901, p. 409, 410

1901b “Campaña del Yaqui y Yucatán” vol. 1, núm. 22, 15 abril 1901, p.482.

1901c “Campaña de Yucatán” vol. 1, núm. 23, 1º mayo 1901, p.508, 509.

1901d “Campaña del Yaqui y Yucatán” vol. 1, núm. 20, 15 de marzo 1901 p.439
MM

1901e “Campaña de Yucatán. Examen bajo el punto de vista estratégico de la campaña” vol. 2, núm.1, 1º de junio 1901, p. 17-19.

1901f “La campaña de Yucatán” vol. 2, núm. 3, 1º de junio 1901, p. 62.

Nogué, Joan

2007 *La construcción social del paisaje*. Serie Paisaje y Teoría núm. 1, Biblioteca Nueva, Madrid, España, pp. 343.

Normark, Johan

2003 Caves and settlement in the ejido of Sacalaca. In *Final Report of Coahuah Regional Archaeological Survey's 2003 Field Season*, edited by Justine M. Shaw, pp. 70-91. College of the Redwoods, Eureka, CA.

2008a Gruta de Alux. In *The Final Report of the Coahuah Regional Archaeological Survey's 2008 Field Season*, edited by Justine M. Shaw, pp. 44-47. College of the Redwoods, Eureka.

2008b Rancho Benito Juarez. In, *Final Report of the Coahuah Archaeological Survey's 2008 Field Season*, ed. by Justine M. Shaw. College of the Redwoods, Eureka.

Ortiz Lanz José Enrique

1993 *Arquitectura militar de México*, Secretaría de la Defensa Nacional Estado mayor de la Defensa Nacional, México, pp.29.2

Pennington Terence D. y José Sarukhán

2005 *Árboles tropicales de México. Manual para la identificación de las especies*, Universidad Nacional autónoma de México, Fondo de Cultura Económica, Ciudad de México, México.

Quezada, Sergio

2001 *Breve historia de Yucatán*, Fondo de Cultura Económica, Colegio de México, Ciudad de México, México.

Reed, Nelson

2007 *La Guerra de Castas*, Biblioteca Era, Ediciones decimosegunda reimpresión, México.

Reents-Budet, Dorie

2001 Classic Maya Concepts of the Royal Court: An Analysis of Renderings on Pictorial Ceramics, in *Royal Courts of the Ancient Maya*, ed. by Takeshi Inomata and Stephen Houston, pp.195-236, Westview Press, Colorado.

Reyes, Bernardo (General de División)

1902 *Memoria de la Secretaría de Estado y Del despacho del Guerra y Marina*. Presentada al Congreso de la Unión por El Secretario del Ramo Gral. de División Bernardo Reyes. Comprende del 1° de Enero de 1900 al 30 de junio de 1901. (Anexos) Tomo II, México.

Sánchez Medrano, Jesús

2007 *Buctzotz en el siglo XIX. Episodios Históricos*, Compañía Editorial de la Península, Mérida, Yucatán, México.

Scarborough, Vernon L. and Fred Valdez, Jr.

2008 An Alternative Order: The Dualistic Economies of the Ancient Maya. *Latin American Antiquity* 20(1):207-227.

Shaw, Justine M.

2005 "Sisal Operation 1," In *Final Report of the 2005 – Coahuah Regional Archaeological Survey*, edited by Justine M. Shaw. College of the Redwoods, Eureka, CA.

Shaw Justine M. (ed.)

2002 Final Reporte of Proyecto Arqueológico Yo'okop's 2002 Field Season: Excavations and Continued Mapping, College of the Redwoods Eureka, CA.

2008 Reporte final del Proyecto de Reconocimiento de la Región de Coahuah Temporada de Campo 2008, College of the Redwoods Eureka, CA.

Shaw, Justine M. and Alberto G. Flores Colin

2008 "Sisal," In *Final Report of the 2008 Field Season –Coahuah Regional Archaeological Survey*, edited by Justine M. Shaw. College of the Redwoods, Eureka, CA.

Shaw, Justine and Dave Johnstone

2000 Final Report of the 2000 Yo'okop Field Season: Initial Mapping and Surface Collections, College of the Redwoods Eureka, CA.

Shaw, Justine M, Dave Johnstone and Ruth Krochock

2000 Architecture, In *Final Report of the 2000 Yo'okop Field Season: Initial Mapping and Surface Collection*, pp. 43-45, College of the Redwoods, Eureka, CA.

Tuan, Ti-Fu

2007 *Space and Place, The Perspective of Experience*. University of Minnesota Press, Minneapolis.

Villalobos, Alejandro

2010 Las pirámides: procesos de edificación. Tecnología constructiva Mesoamericana, in *Arqueología Mexicana*, Vol. XVII, Núm. 101, CONACULTA, INAH, Editorial Raíces, Ciudad de México, México.

Villalpando, José Manuel and Rosas Alejandro

2003 *Historia de México a través de sus gobernantes*, Editorial Planeta.

Wilson, Reginald

1974 Okop: Antigua Ciudad Maya de Artesanos, in *Boletín INAH*, Época II, núm. 9, pp. 3-14, Instituto Nacional de Antropología e Historia, México.

Young, Tatiana

2005 CRAS 2005: Mapping and Excavations at Parcela Escolar, In *Final Report of the Coahuah Regional Archaeological Survey's Field Season*, ed. by Justine M. Shaw, pp. 116-124, College of the Redwoods, Eureka, CA.